

Sound Processor Series for Car Audio

# Sound Processors with Built-in 3-band Equalizer

**BD37531FV, BD37532FV, BD37533FV, BD37534FV**

No.10085EAT06

## ●Description

BD37531FV, BD37532FV, BD37533FV, BD37534FV are sound processors built-in 3-band equalizer for car audio. The functions are stereo input selector available to switch single end input and ground isolation input, input-gain control, main volume, loudness, 5ch fader volume, LPF for subwoofer(except BD37531FV), mixing input(except BD37531FV, BD37532FV). Moreover, "Advanced switch circuit", that is ROHM original technology, can reduce various switching noise (ex. No-signal, low frequency likes 20Hz & large signal inputs). "Advanced switch" makes control of microcomputer easier, and can construct high quality car audio system.

## ●Features

- 1) Reduce switching noise of input gain control, mute, main volume, fader volume, bass, middle, treble, loudness by using advanced switch circuit [Possible to control all steps]
- 2) Built-in differential input selector that can make various combination of single-ended / differential input.
- 3) Built-in ground isolation amplifier inputs, ideal for external stereo input.
- 4) Built-in input gain controller reduces switching noise for volume of a portable audio input.
- 5) Decrease the number of external components by built-in 3-band equalizer filter, LPF for subwoofer (except BD37531FV), loudness filter. And, possible to control Q, Gv, fo of 3-band equalizer and fc of LPF, Gv of loudness by I<sup>2</sup>C BUS control freely
- 6) It is possible for the bass, middle, treble to the gain adjustment quantity of  $\pm 20$ dB and 1 dB step gain adjustment.
- 7) Terminals for the subwoofer outputs are equipped, and the audio signal outputs of front, back and subwoofer can be chosen with the I2C BUS control.
- 8) Built-in mixing input, mixing attenuator. (except BD37531FV, BD37532FV)
- 9) Bi-CMOS process is suitable for the design of low current and low energy. And it provides more quality for small scale regulator and heat in a set.
- 10) Package is SSOP-B28. Putting input-terminals together and output-terminals together can make PCB layout easier and can makes area of PCB smaller.
- 11) It is possible to control by 3.3V / 5V for I<sup>2</sup>C BUS.

## ●Applications

It is the optimal for the car audio. Besides, it is possible to use for the audio equipment of mini Compo, micro Compo, TV etc with all kinds.

● Line up matrix

Function	BD37531FV	BD37532FV	BD37533FV	BD37534FV	Specifications																												
Input selector	○	○	○	○	<ul style="list-style-type: none"> <li>• (Stereo input)</li> <li>• Single-End/Diff/Full-Diff</li> </ul> (Possible to set the number of single-end/diff/full-diff as follows ) <table border="1"> <thead> <tr> <th></th> <th>Single-End</th> <th>Differential</th> <th>Full-Differential</th> </tr> </thead> <tbody> <tr> <td>Mode 1</td> <td>0</td> <td>3</td> <td>1</td> </tr> <tr> <td>Mode 2</td> <td>1</td> <td>2</td> <td>1</td> </tr> <tr> <td>Mode 3</td> <td>3</td> <td>1</td> <td>1</td> </tr> <tr> <td>Mode 4</td> <td>4</td> <td>0</td> <td>1</td> </tr> <tr> <td>Mode 5</td> <td>5</td> <td>1</td> <td>0</td> </tr> <tr> <td>Mode 6</td> <td>6</td> <td>0</td> <td>0</td> </tr> </tbody> </table> Table.1 Combination of input selector		Single-End	Differential	Full-Differential	Mode 1	0	3	1	Mode 2	1	2	1	Mode 3	3	1	1	Mode 4	4	0	1	Mode 5	5	1	0	Mode 6	6	0	0
	Single-End	Differential	Full-Differential																														
Mode 1	0	3	1																														
Mode 2	1	2	1																														
Mode 3	3	1	1																														
Mode 4	4	0	1																														
Mode 5	5	1	0																														
Mode 6	6	0	0																														
Input gain	○	○	○	○	<ul style="list-style-type: none"> <li>• 0~20dB (1dB step)</li> <li>• Possible to use "Advanced switch" for prevention of switching noise.</li> </ul>																												
Mute	○	○	○	○	<ul style="list-style-type: none"> <li>• Possible to use "Advanced switch" for prevention of switching noise.</li> </ul>																												
Volume	○	○	○	○	<ul style="list-style-type: none"> <li>• +15dB~-79dB (1dB step) , -∞</li> <li>• Possible to use "Advanced switch" for prevention of switching noise.</li> </ul>																												
Bass	○	○	○	○	<ul style="list-style-type: none"> <li>• -20~+20dB (1dB step)</li> <li>• Q=0.5, 1, 1.5, 2</li> <li>• fo=60, 80, 100, 120Hz</li> <li>• Possible to use "Advanced switch" at changing gain</li> </ul>																												
Middle	○	○	○	○	<ul style="list-style-type: none"> <li>• -20~+20dB (1dB step)</li> <li>• Q=0.75, 1, 1.25, 1.5</li> <li>• fo=500, 1k, 1.5k 2.5kHz</li> <li>• Possible to use "Advanced switch" at changing gain</li> </ul>																												
Treble	○	○	○	○	<ul style="list-style-type: none"> <li>• -20~+20dB (1dB step)</li> <li>• Q=0.75, 1.25</li> <li>• fo=7.5k, 10k, 12.5k, 15kHz</li> <li>• Possible to use "Advanced switch" at changing gain</li> </ul>																												
Fader	○	○	○	○	<ul style="list-style-type: none"> <li>• +15dB~-79dB(1dB step), -∞dB (BD37531FV : 0dB~-79dB, -∞dB)</li> <li>• Possible to use "Advanced switch" for prevention of switching noise.</li> </ul>																												
Loudness	○	○	○	○	<ul style="list-style-type: none"> <li>• 0dB~20dB(1dB step)</li> <li>• fo=250/400/800Hz</li> <li>• Possible to use "Advanced switch" for prevention of switching noise.</li> </ul>																												
LPF	×	○	○	○	<ul style="list-style-type: none"> <li>• fc=55/85/120/160Hz, pass</li> <li>• Phase shift (0°/180°)</li> </ul>																												
Mixing	×	×	○	○	<ul style="list-style-type: none"> <li>• Monaural input</li> <li>• +7dB~-79dB (1dB step) , -∞</li> <li>• Possible to use "Advanced switch" for prevention of switching noise.</li> </ul>																												
Level meter	×	×	×	○	<ul style="list-style-type: none"> <li>• I2C BUS control</li> <li>• DC Output</li> </ul>																												

● Absolute maximum ratings (Ta=25°C)

Item	Symbol	Rating	Unit
Power supply Voltage	VCC	10.0	V
Input voltage	Vin	VCC+0.3~GND-0.3	V
Power Dissipation	Pd	1063 ※1	mW
Storage Temperature	Tastg	-55~+150	°C

※This value decreases 8.5mW/°C for Ta=25°C or more.

ROHM standard board shall be mounted.

Thermal resistance  $\theta_{ja} = 117.6(^{\circ}\text{C}/\text{W})$

ROHM Standard board

Size : 70×70×1.6(mm<sup>3</sup>)

Material : A FR4 glass epoxy board(3% or less of copper foil area)

● Operating conditions

Item	Symbol	MIN	TYP	MAX	Unit
Power supply Voltage	VCC	7.0	—	9.5	V
Temperature	Topr	-40	—	+85	°C

## ● Electrical characteristics

(Unless specified particularly, Ta=25°C, VCC=8.5V, f=1kHz, Vin=1Vrms, Rg=600Ω, RL=10kΩ, A1 input, Input gain 0dB, Mute off, Volume 0dB, Tone control 0dB, Loudness 0dB, LPF OFF(BD37532FV, BD37533FV, BD37534FV), Mixing OFF(BD37533FV, BD37534FV), Fader 0dB)

BLOCK	Item	Symbol	Limit			Unit	Condition
			Min.	Typ.	Max.		
GENERAL	Current upon no signal	I <sub>Q</sub>	—	38	48	mA	No signal
	Voltage gain	G <sub>V</sub>	-1.5	0	1.5	dB	G <sub>V</sub> =20log(VOUT/VIN)
	Channel balance	CB	-1.5	0	1.5	dB	CB = GV1-GV2
	Total harmonic distortion 1 (FRONT, REAR)	THD+N1	—	0.001	0.05	%	VOUT=1Vrms BW=400-30KHz
	Total harmonic distortion 2 (SUBWOOFER)	THD+N2	—	0.002	0.05	%	VOUT=1Vrms BW=400-30KHz
	Output noise voltage 1 (FRONT, REAR) *	V <sub>NO1</sub>	—	3.8	15	μVrms	Rg = 0Ω BW = IHF-A
	Output noise voltage 2 (SUBWOOFER) *	V <sub>NO2</sub>	—	4.8	15	μVrms	Rg = 0Ω BW = IHF-A
	Residual output noise voltage *	V <sub>NOR</sub>	—	1.8	10	μVrms	Fader = -∞dB Rg = 0Ω BW = IHF-A
	Cross-talk between channels *	CTC	—	-100	-90	dB	Rg = 0Ω CTC=20log(VOUT/VIN) BW = IHF-A
	Ripple rejection	RR	—	-70	-40	dB	f=1kHz VRR=100mVrms RR=20log(VCC IN/VOUT)
INPUT SELECTOR	Input impedance(A, B, C)	R <sub>IN_S</sub>	70	100	130	kΩ	
	Input impedance (D, E)	R <sub>IN_D</sub>	175	250	325	kΩ	
	Maximum input voltage	V <sub>IM</sub>	2.1	2.3	—	Vrms	VIM at THD+N(VOUT)=1% BW=400-30KHz
	Cross-talk between selectors	CTS	—	-100	-90	dB	CTS=20log(VOUT/VIN) BW = IHF-A
	Common mode rejection ratio * (D, E)	CMRR	50	65	—	dB	XP1 and XN input XP2 and XN input CMRR=20log(VIN/VOUT) BW = IHF-A, [※X · · · D, E]
INPUT GAIN	Minimum input gain	G <sub>IN MIN</sub>	-2	0	+2	dB	Input gain 0dB VIN=100mVrms Gin=20log(VOUT/VIN)
	Maximum input gain	G <sub>IN MAX</sub>	+18	+20	+22	dB	Input gain +20dB VIN=100mVrms Gin=20log(VOUT/VIN)
	Gain set error	G <sub>IN ERR</sub>	-2	0	+2	dB	GAIN=+20~-+1dB
MUTE	Mute attenuation *	G <sub>MUTE</sub>	—	-105	-85	dB	Mute ON Gmute=20log(VOUT/VIN) BW = IHF-A
VOLUME	Maximum gain	G <sub>V MAX</sub>	13	15	17	dB	Volume = 15dB VIN=100mVrms Gv=20log(VOUT/VIN)
	Maximum attenuation *	G <sub>V MIN</sub>	—	-100	-85	dB	Volume = -∞dB Gv=20log(VOUT/VIN) BW = IHF-A
	Attenuation set error 1	G <sub>V ERR1</sub>	-2	0	2	dB	GAIN & ATT=+15dB~-15dB
	Attenuation set error 2	G <sub>V ERR2</sub>	-3	0	3	dB	ATT=-16dB~-47dB
	Attenuation set error 3	G <sub>V ERR3</sub>	-4	0	4	dB	ATT=-48dB~-79dB

BLOCK	Item	Symbol	Limit			Unit	Condition
			Min.	Typ.	Max.		
BASS	Maximum boost gain	$G_{B\text{ BST}}$	18	20	22	dB	Gain=+20dB f=100Hz VIN=100mVrms $G_B=20\log(V_{OUT}/V_{IN})$
	Maximum cut gain	$G_{B\text{ CUT}}$	-22	-20	-18	dB	Gain=-20dB f=100Hz VIN=2Vrms $G_B=20\log(V_{OUT}/V_{IN})$
	Gain set error	$G_{B\text{ ERR}}$	-2	0	2	dB	Gain=-20~+20dB f=100Hz
MIDDLE	Maximum boost gain	$G_{M\text{ BST}}$	18	20	22	dB	Gain=+20dB f=1kHz VIN=100mVrms $G_M=20\log(V_{OUT}/V_{IN})$
	Maximum cut gain	$G_{M\text{ CUT}}$	-22	-20	-18	dB	Gain=-20dB f=1kHz VIN=2Vrms $G_M=20\log(V_{OUT}/V_{IN})$
	Gain set error	$G_{M\text{ ERR}}$	-2	0	2	dB	Gain=-20~+20dB f=1kHz
TREBLE	Maximum boost gain	$G_{T\text{ BST}}$	17	20	23	dB	Gain=+20dB f=10kHz VIN=100mVrms $G_T=20\log(V_{OUT}/V_{IN})$
	Maximum cut gain	$G_{T\text{ CUT}}$	-23	-20	-17	dB	Gain=-20dB f=10kHz VIN=2Vrms $G_T=20\log(V_{OUT}/V_{IN})$
	Gain set error	$G_{T\text{ ERR}}$	-2	0	2	dB	Gain=-20~+20dB f=10kHz
MIXING (BD37533FV, BD37534FV)	Input impedance	$R_{IN\text{ M}}$	19	27	35	k $\Omega$	
	Maximum input voltage	$V_{IM\text{ M}}$	2.0	2.2	—	Vrms	VIM at THD+N(VOUT)=1% BW=400-30KHz
	Maximum attenuation	$G_{MX\text{ MIN}}$	—	-100	-85	dB	MIX=OFF $G_{MX}=20\log(V_{OUT}/V_{IN})$ BW=INF-A
	Maximum gain	$G_{MX\text{ MAX}}$	5	7	9	dB	ATT=+6dB $G_{MX}=20\log(V_{OUT}/V_{IN})$
FADER / SUBWOOFER	Maximum boost gain (BD37532FV, BD37533FV, BD37534FV)	$G_{F\text{ BST}}$	13	15	17	dB	Fader=15dB VIN=100mVrms $G_F=20\log(V_{OUT}/V_{IN})$
	Maximum attenuation *	$G_{F\text{ MIN}}$	—	-100	-90	dB	Fader = - $\infty$ dB $G_F=20\log(V_{OUT}/V_{IN})$ BW = IHF-A
	Gain set error (BD37532FV, BD37533FV, BD37534FV)	$G_{F\text{ ERR}}$	-2	0	2	dB	Gain=+1~+15dB
	Attenuation set error 1	$G_{F\text{ ERR1}}$	-2	0	2	dB	ATT=-1~-15dB
	Attenuation set error 2	$G_{F\text{ ERR2}}$	-3	0	3	dB	ATT=-16~-47dB
	Attenuation set error 3	$G_{F\text{ ERR3}}$	-4	0	4	dB	ATT=-48~-79dB
	Output impedance	$R_{OUT}$	-	—	50	$\Omega$	VIN=100mVrms
Maximum output voltage	$V_{OM}$	2	2.2	—	Vrms	THD+N=1% BW=400-30KHz	
LOUDNESS	Maximum gain	$G_{L\text{ MAX}}$	17	20	23	dB	Gain 20dB VIN=100mVrms $G_L=20\log(V_{OUT}/V_{IN})$
	Gain set error	$G_{L\text{ ERR}}$	-2	0	2	dB	GAIN=+20~+1dB
Level meter (BD37534FV)	Maximum output voltage	$V_{L\text{ MAX}}$	2.8	3.1	3.5	V	
	Output offset voltage	$V_{L\text{ OFF}}$	-	0	100	mV	

VP-9690A(Average value detection, effective value display) filter by Matsushita Communication is used for \* measurement.  
Phase between input / output is same.

●Electrical characteristic curves (Reference data)

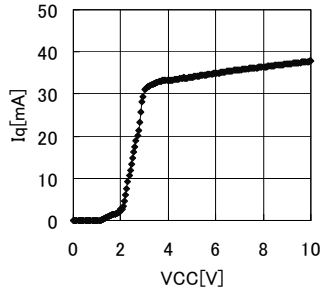

Fig.1 Iq vs Vcc

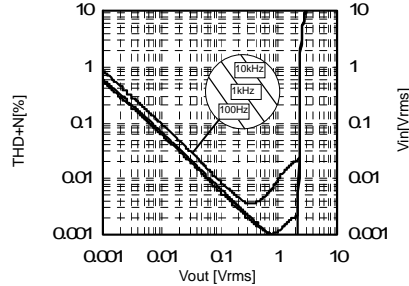

Fig.2 Thd vs Vo

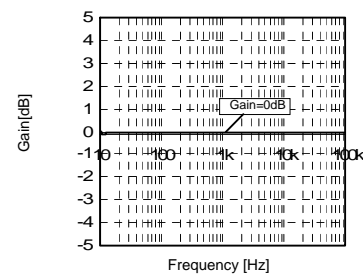

Fig.3 Gain vs Freq

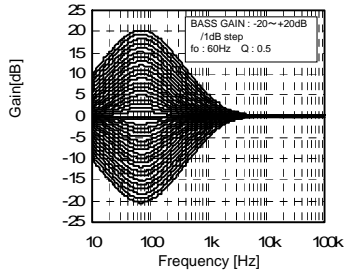

Fig.4 Bass Gain vs Freq

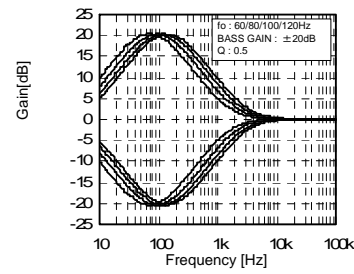

Fig.5 Bass fo vs Freq

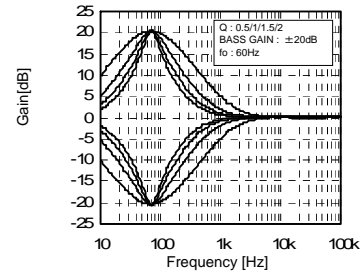

Fig.6 Bass Q vs Freq

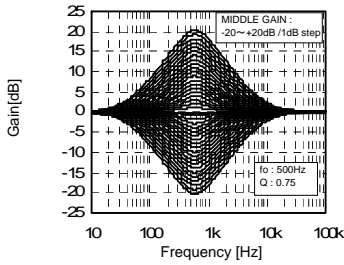

Fig.7 Middle Gain vs Freq

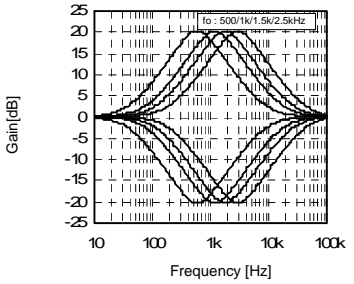

Fig.8 Middle fo vs Freq

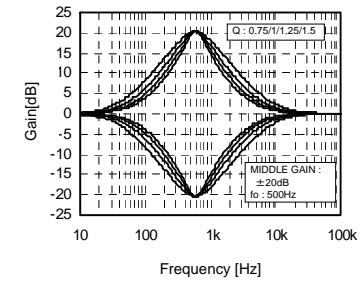

Fig.9 Middle Q vs Freq

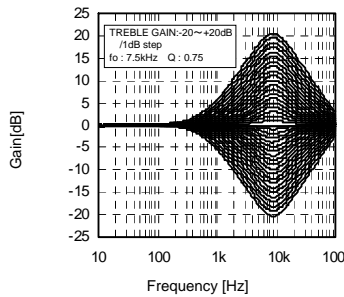

Fig.10 Treble Gain vs Freq

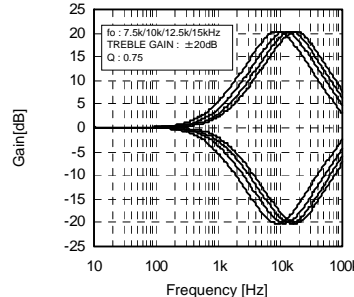

Fig.11 Treble fo vs Freq

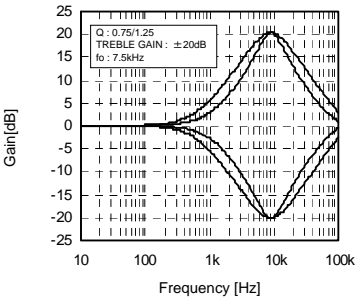

Fig.12 Treble Q vs Freq

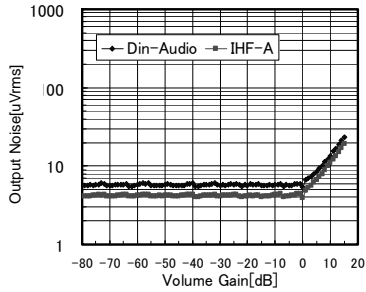

Fig.13 Volume Gain vs Noise

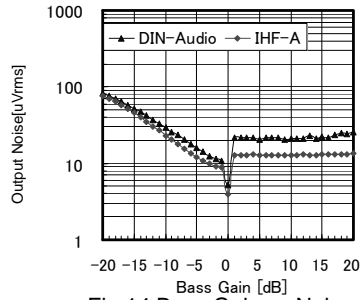

Fig.14 Bass Gain vs Noise

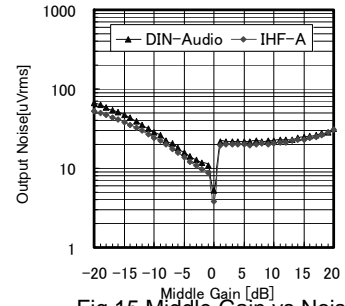

Fig.15 Middle Gain vs Noise

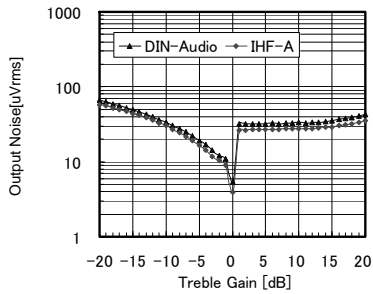

Fig.16 Treble Gain vs Noise

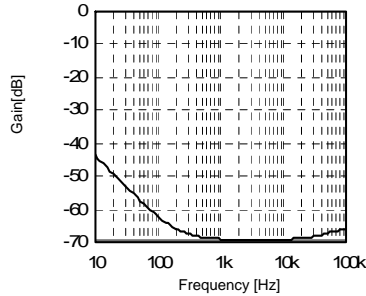

Fig.17 CMRR vs Freq

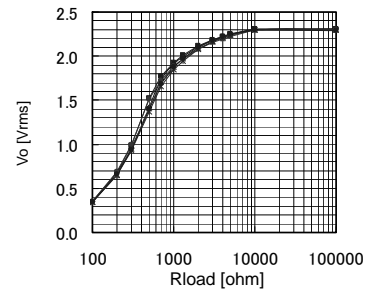

Fig.18 Rload vs Vo

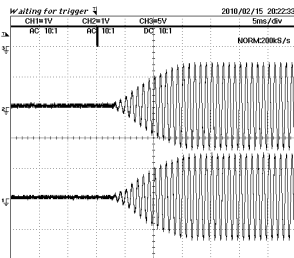

Fig.19 Advanced Switch 1

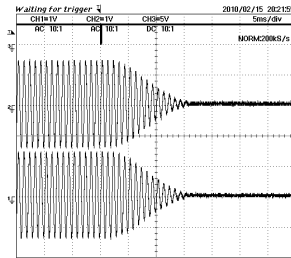

Fig.20 Advanced Switch 2

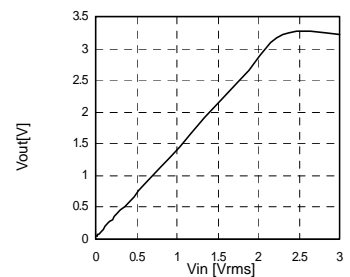

Fig.21 Level Meter Vin vs Vo

Fig.21 : Level Meter function is available only BD37534FV

●Block diagram and pin configuration

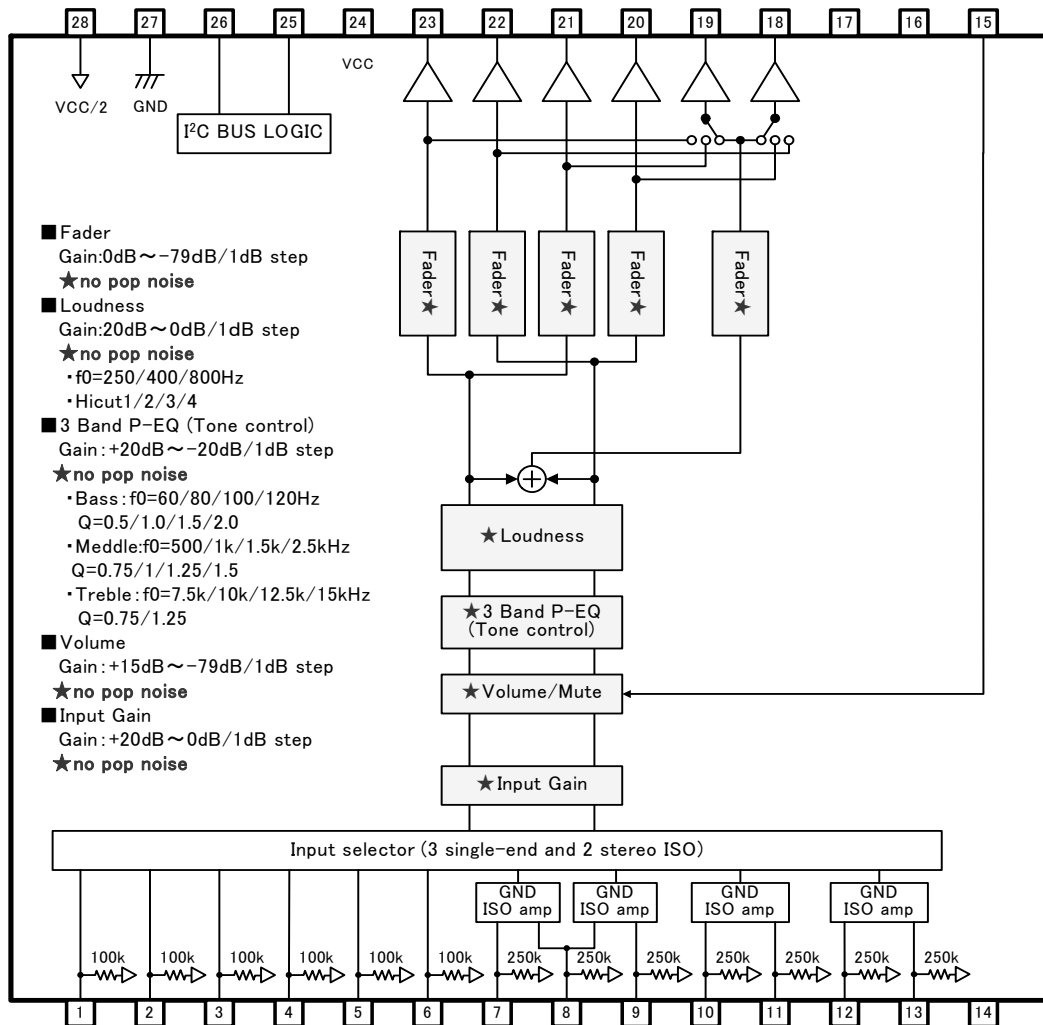

Fig.22 BD37531FV

Descriptions of terminal

Terminal No.	Terminal Name	Description	Terminal No.	Terminal Name	Description
1	A1	A input terminal of 1ch	15	MUTE	External compulsory mute terminal
2	A2	A input terminal of 2ch	16	TEST2	Test Pin
3	B1	B input terminal of 1ch	17	TEST3	Test Pin
4	B2	B input terminal of 2ch	18	OUTS2	Subwoofer output terminal of 2ch
5	C1	C input terminal of 1ch	19	OUTS1	Subwoofer output terminal of 1ch
6	C2	C input terminal of 2ch	20	OUTR2	Rear output terminal of 2ch
7	DP1	D positive input terminal of 1ch	21	OUTR1	Rear output terminal of 1ch
8	DN	D negative input terminal	22	OUTF2	Front output terminal of 2ch
9	DP2	D positive input terminal of 2ch	23	OUTF1	Front output terminal of 1ch
10	EP1	E positive input terminal of 1ch	24	VCC	Power supply terminal
11	EN1	E negative input terminal of 1ch	25	SCL	I <sup>2</sup> C Communication clock terminal
12	EN2	E negative input terminal of 2ch	26	SDA	I <sup>2</sup> C Communication data terminal
13	EP2	E positive input terminal of 2ch	27	GND	GND terminal
14	TEST1	Test Pin	28	FIL	VCC/2 terminal



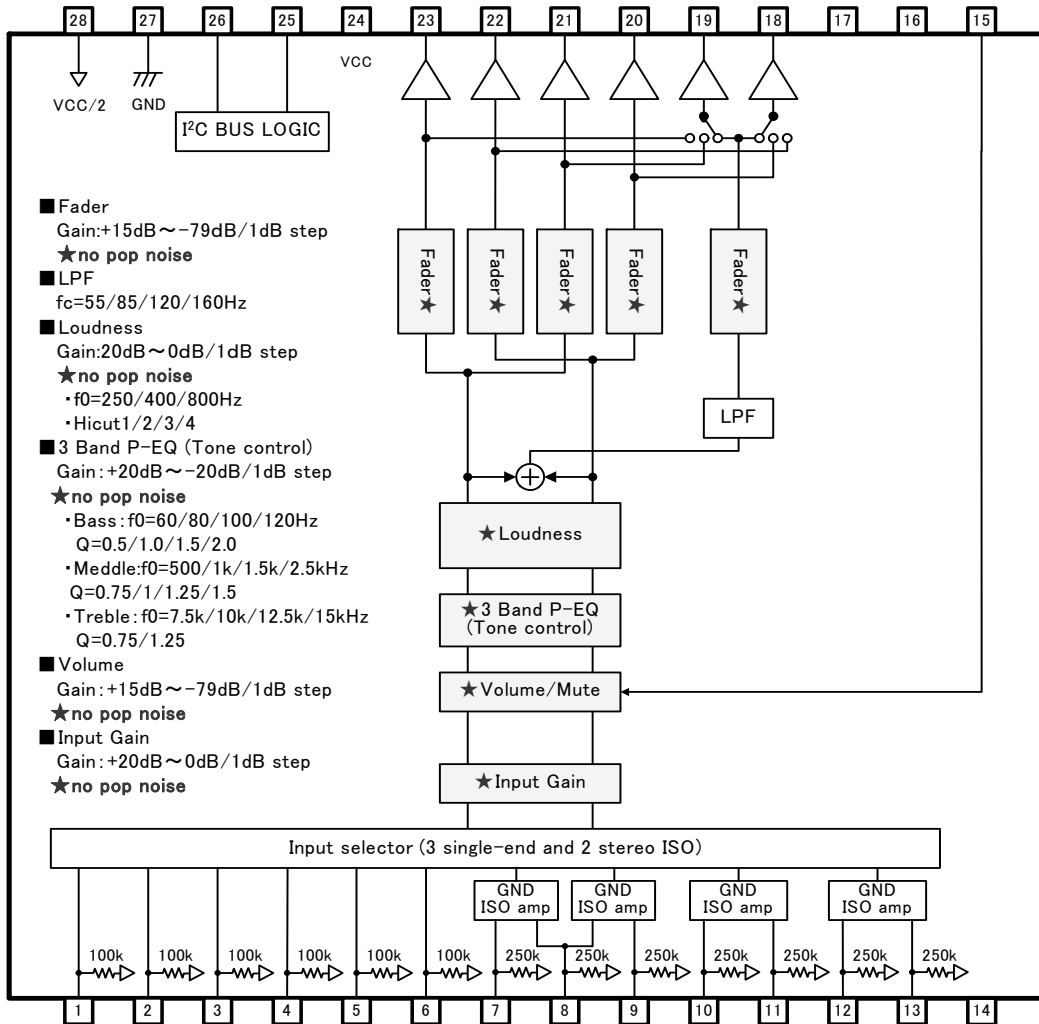

Fig.23 BD37532FV

Descriptions of terminal

Terminal No.	Terminal Name	Description	Terminal No.	Terminal Name	Description
1	A1	A input terminal of 1ch	15	MUTE	External compulsory mute terminal
2	A2	A input terminal of 2ch	16	TEST2	Test Pin
3	B1	B input terminal of 1ch	17	TEST3	Test Pin
4	B2	B input terminal of 2ch	18	OUTS2	Subwoofer output terminal of 2ch
5	C1	C input terminal of 1ch	19	OUTS1	Subwoofer output terminal of 1ch
6	C2	C input terminal of 2ch	20	OUTR2	Rear output terminal of 2ch
7	DP1	D positive input terminal of 1ch	21	OUTR1	Rear output terminal of 1ch
8	DN	D negative input terminal	22	OUTF2	Front output terminal of 2ch
9	DP2	D positive input terminal of 2ch	23	OUTF1	Front output terminal of 1ch
10	EP1	E positive input terminal of 1ch	24	VCC	Power supply terminal
11	EN1	E negative input terminal of 1ch	25	SCL	I <sup>2</sup> C Communication clock terminal
12	EN2	E negative input terminal of 2ch	26	SDA	I <sup>2</sup> C Communication data terminal
13	EP2	E positive input terminal of 2ch	27	GND	GND terminal
14	TEST1	Test Pin	28	FIL	VCC/2 terminal

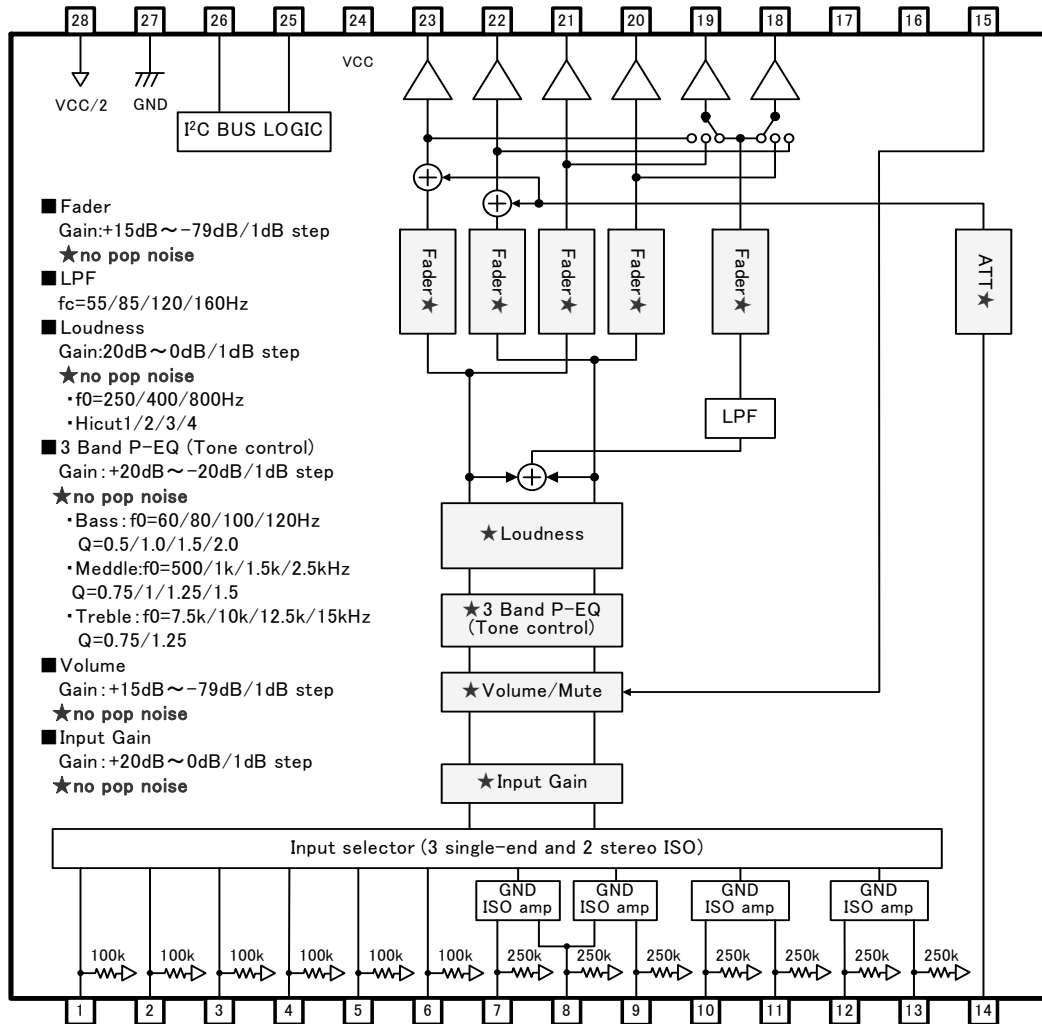

Fig.24 BD37533FV

Descriptions of terminal

Terminal No.	Terminal Name	Description	Terminal No.	Terminal Name	Description
1	A1	A input terminal of 1ch	15	MUTE	External compulsory mute terminal
2	A2	A input terminal of 2ch	16	TEST1	Test Pin
3	B1	B input terminal of 1ch	17	TEST2	Test Pin
4	B2	B input terminal of 2ch	18	OUTS2	Subwoofer output terminal of 2ch
5	C1	C input terminal of 1ch	19	OUTS1	Subwoofer output terminal of 1ch
6	C2	C input terminal of 2ch	20	OUTR2	Rear output terminal of 2ch
7	DP1	D positive input terminal of 1ch	21	OUTR1	Rear output terminal of 1ch
8	DN	D negative input terminal	22	OUTF2	Front output terminal of 2ch
9	DP2	D positive input terminal of 2ch	23	OUTF1	Front output terminal of 1ch
10	EP1	E positive input terminal of 1ch	24	VCC	Power supply terminal
11	EN1	E negative input terminal of 1ch	25	SCL	I <sup>2</sup> C Communication clock terminal
12	EN2	E negative input terminal of 2ch	26	SDA	I <sup>2</sup> C Communication data terminal
13	EP2	E positive input terminal of 2ch	27	GND	GND terminal
14	MIN	Mixing input terminal	28	FIL	VCC/2 terminal

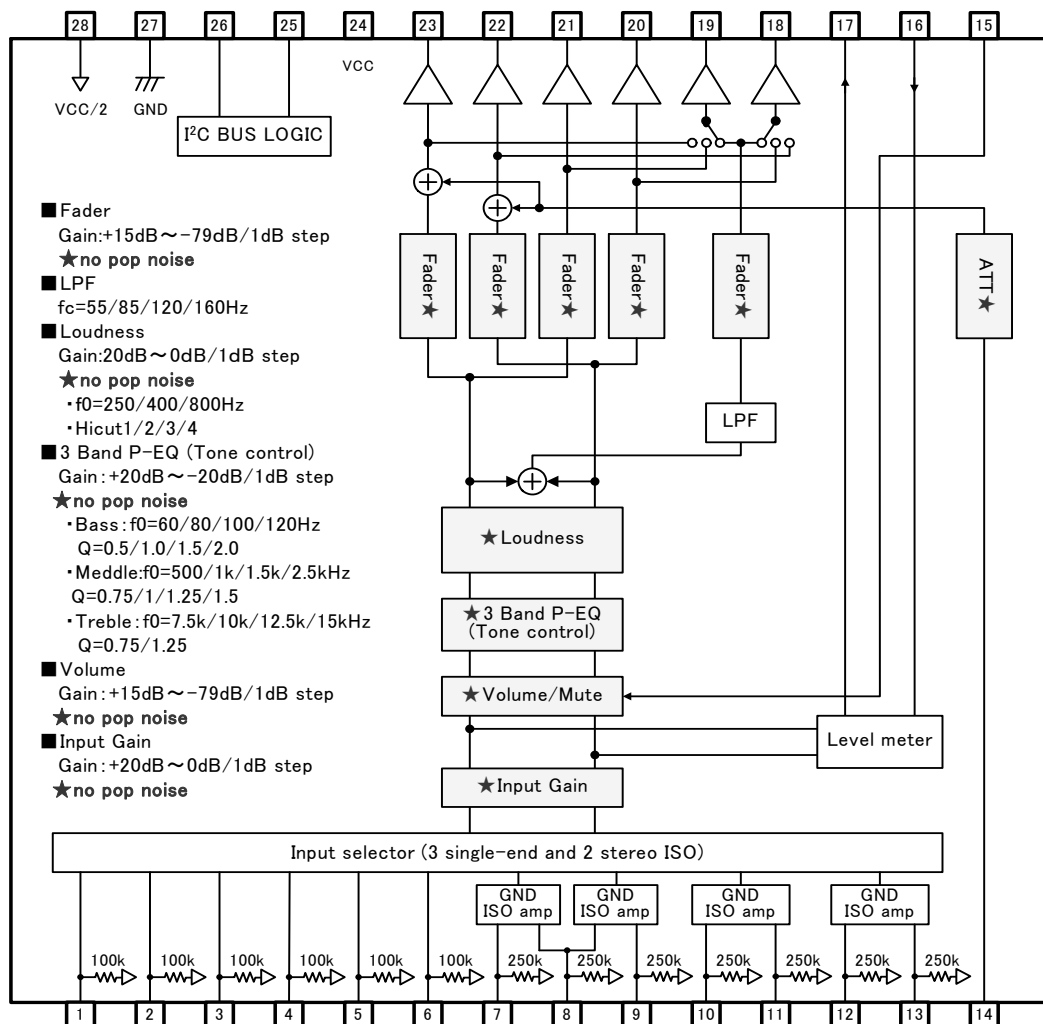

Fig.25 BD37534FV

Descriptions of terminal

Terminal No.	Terminal Name	Description	Terminal No.	Terminal Name	Description
1	A1	A input terminal of 1ch	15	MUTE	External compulsory mute terminal
2	A2	A input terminal of 2ch	16	LRST	Level meter reset terminal
3	B1	B input terminal of 1ch	17	LOUT	Output terminal for Level meter
4	B2	B input terminal of 2ch	18	OUTS2	Subwoofer output terminal of 2ch
5	C1	C input terminal of 1ch	19	OUTS1	Subwoofer output terminal of 1ch
6	C2	C input terminal of 2ch	20	OUTR2	Rear output terminal of 2ch
7	DP1	D positive input terminal of 1ch	21	OUTR1	Rear output terminal of 1ch
8	DN	D negative input terminal	22	OUTF2	Front output terminal of 2ch
9	DP2	D positive input terminal of 2ch	23	OUTF1	Front output terminal of 1ch
10	EP1	E positive input terminal of 1ch	24	VCC	Power supply terminal
11	EN1	E negative input terminal of 1ch	25	SCL	I <sup>2</sup> C Communication clock terminal
12	EN2	E negative input terminal of 2ch	26	SDA	I <sup>2</sup> C Communication data terminal
13	EP2	E positive input terminal of 2ch	27	GND	GND terminal
14	MIN	Mixing input terminal	28	FIL	VCC/2 terminal

●Timing Chart

CONTROL SIGNAL SPECIFICATION

(1) Electrical specifications and timing for bus lines and I/O stages

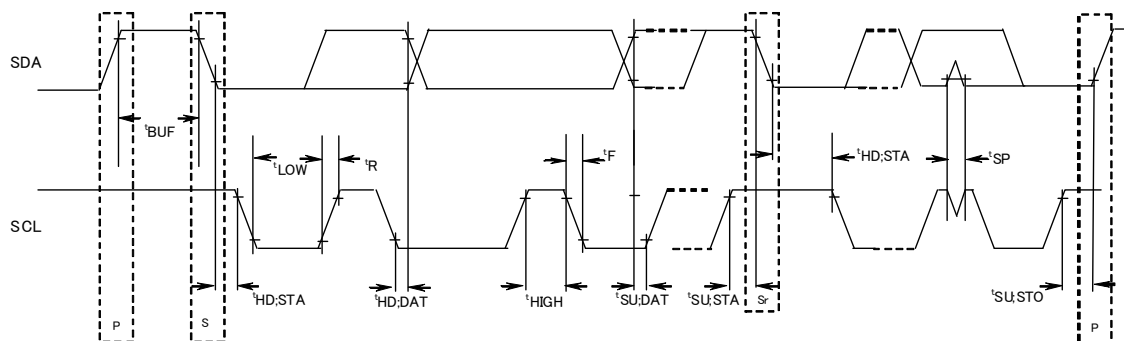

Fig.26 Definition of timing on the I<sup>2</sup>C-bus

Table 1 Characteristics of the SDA and SCL bus lines for I<sup>2</sup>C-bus devices  
(Unless specified particularly, Ta=25°C, VCC=8.5V)

Parameter		Symbol	Fast-mode I <sup>2</sup> C-bus		Unit
			Min.	Max.	
1	SCL clock frequency	f SCL	0	400	kHz
2	Bus free time between a STOP and START condition	tBUF	1.3	—	μS
3	Hold time (repeated) START condition. After this period, the first clock pulse is generated	tHD:STA	0.6	—	μS
4	LOW period of the SCL clock	tLOW	1.3	—	μS
5	HIGH period of the SCL clock	tHIGH	0.6	—	μS
6	Set-up time for a repeated START condition	tSU:STA	0.6	—	μS
7	Data hold time:	tHD:DAT	0.06*	—	μS
8	Data set-up time	tSU:DAT	120	—	ns
9	Set-up time for STOP condition	tSU:STO	0.6	—	μS

All values referred to VIH min. and VIL max. Levels (see Table 2).

\* A device must internally provide a hold time of at least 300 ns for the SDA signal (referred to the VIH min. of the SCL signal) in order to bridge the undefined region of the falling edge of SCL.  
About 7(tHD;DAT), 8(tSU;DAT), make it the setup which a margin is fully in .

Table 2 Characteristics of the SDA and SCL I/O stages for I<sup>2</sup>C-bus devices

Parameter	Symbol	Fast-mode devices		Unit
		Min.	Max.	
10 LOW level input voltage:	V <sub>IL</sub>	-0.3	1	V
11 HIGH level input voltage:	V <sub>IH</sub>	2.3	5	V
12 Pulse width of spikes which must be suppressed by the input filter.	t <sub>SP</sub>	0	50	ns
13 LOW level output voltage: at 3mA sink current	V <sub>OL1</sub>	0	0.4	V
14 Input current each I/O pin with an input voltage between 0.4V and 4.5V.	I <sub>i</sub>	-10	10	μA

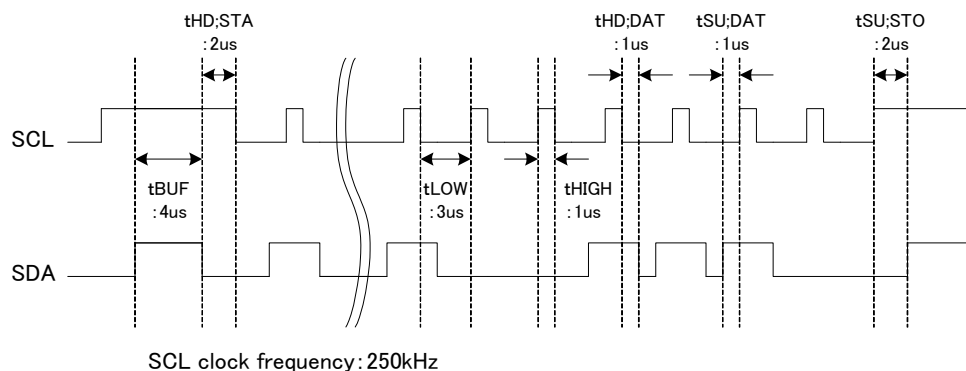
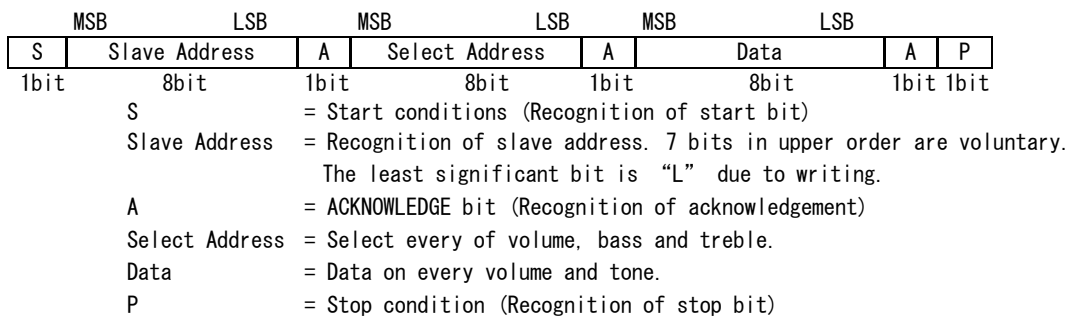

Fig. 27 A command timing example in the I2C data transmission

(2) I<sup>2</sup>C BUS FORMAT



(3) I<sup>2</sup>C BUS Interface Protocol

1) Basic form

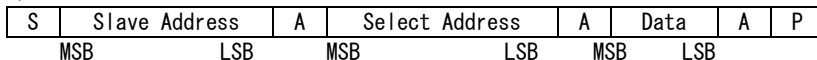

2) Automatic increment (Select Address increases (+1) according to the number of data.

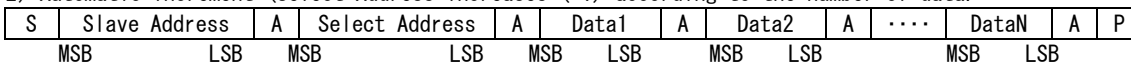

- (Example) ①Data1 shall be set as data of address specified by Select Address.  
 ②Data2 shall be set as data of address specified by Select Address +1.  
 ③DataN shall be set as data of address specified by Select Address +N-1.

3) Configuration unavailable for transmission (In this case, only Select Address1 is set.

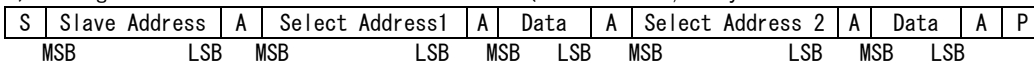

(Note) If any data is transmitted as Select Address 2 next to data, it is recognized as data, not as Select Address 2.

(4) Slave address

	MSB							LSB	
A6	A5	A4	A3	A2	A1	A0	R/W		
1	0	0	0	0	0	0	0		80H

(5) Select Address & Data

BD37531FV

Items	Select Address (hex)	Data							
		MSB	Data						LSB
		D7	D6	D5	D4	D3	D2	D1	D0
Initial setup 1	01	Advanced switch ON/OFF	0	Advanced switch time of Input Gain/Volume Tone/Fader/Loudness		0	1	Advanced switch time of Mute	
Initial setup 2	02	0	0	Subwoofer Output Select		0	0	0	0
Initial setup 3	03	0	0	0	Loudness fo		0	0	1
Input Selector	05	Full-diff Type	0	0	Input selector				
Input gain	06	Mute ON/OFF	0	0	Input Gain				
Volume gain	20	Volume Gain / Attenuation							
Fader 1ch Front	28	Fader Attenuation							
Fader 2ch Front	29	Fader Attenuation							
Fader 1ch Rear	2A	Fader Attenuation							
Fader 2ch Rear	2B	Fader Attenuation							
Fader Subwoofer	2C	Fader Attenuation							
Test Mode	30	1	1	1	1	1	1	1	1
Bass setup	41	0	0	Bass fo		0	0	Bass Q	
Middle setup	44	0	0	Middle fo		0	0	Middle Q	
Treble setup	47	0	0	Treble fo		0	0	0	Treble Q
Bass gain	51	Bass Boost/Cut	0	0	Bass Gain				
Middle gain	54	Middle Boost/Cut	0	0	Middle Gain				
Treble gain	57	Treble Boost/Cut	0	0	Treble Gain				
Loudness Gain	75	0	Loudness Hicut		Loudness Gain				
System Reset	FE	1	0	0	0	0	0	0	1

 Advanced switch

Note

1. In function changing of the hatching part, it works Advanced switch.
2. Upon continuous data transfer, the Select Address is circulated by the automatic increment function, as shown below.

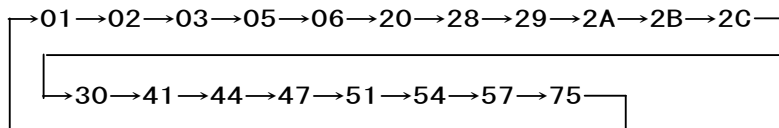

3. For the function of input selector and subwoofer output select etc, it is not corresponded for advanced switch. Therefore, please apply mute on the side of a set when changes these setting.
4. When using mute function of this IC at the time of changing input selector, please switch mute ON/OFF for waiting advanced-mute time.

BD37532FV

Items	Select Address (hex)	Data							
		MSB	Data						LSB
		D7	D6	D5	D4	D3	D2	D1	D0
Initial setup 1	01	Advanced switch ON/OFF	0	Advanced switch time of Input Gain/Volume Tone/Fader/Loudness		0	1	Advanced switch time of Mute	
Initial setup 2	02	LPF Phase	0	Subwoofer Output Select		0	Subwoofer LPF fc		
Initial setup 3	03	0	0	0	Loudness fo		0	0	1
Input Selector	05	Full-diff Type	0	0	Input selector				
Input gain	06	Mute ON/OFF	0	0	Input Gain				
Volume gain	20	Volume Gain / Attenuation							
Fader 1ch Front	28	Fader Gain / Attenuation							
Fader 2ch Front	29	Fader Gain / Attenuation							
Fader 1ch Rear	2A	Fader Gain / Attenuation							
Fader 2ch Rear	2B	Fader Gain / Attenuation							
Fader Subwoofer	2C	Fader Gain / Attenuation							
Test Mode	30	1	1	1	1	1	1	1	1
Bass setup	41	0	0	Bass fo		0	0	Bass Q	
Middle setup	44	0	0	Middle fo		0	0	Middle Q	
Treble setup	47	0	0	Treble fo		0	0	0	Treble Q
Bass gain	51	Bass Boost/Cut	0	0	Bass Gain				
Middle gain	54	Middle Boost/Cut	0	0	Middle Gain				
Treble gain	57	Treble Boost/Cut	0	0	Treble Gain				
Loudness Gain	75	0	Loudness Hicut		Loudness Gain				
System Reset	FE	1	0	0	0	0	0	0	1

 Advanced switch

Note

1. In function changing of the hatching part, it works Advanced switch.
2. Upon continuous data transfer, the Select Address is circulated by the automatic increment function, as shown below.

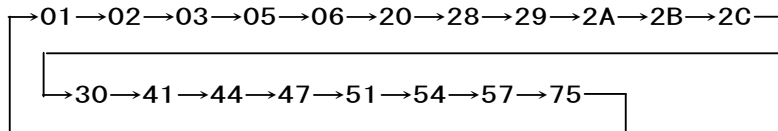

3. For the function of input selector and subwoofer output select etc, it is not corresponded for advanced switch. Therefore, please apply mute on the side of a set when changes these setting.
4. When using mute function of this IC at the time of changing input selector, please switch mute ON/OFF for waiting advanced-mute time.



BD37533FV

Items	Select Address (hex)	Data							
		MSB	Data						LSB
		D7	D6	D5	D4	D3	D2	D1	D0
Initial setup 1	01	Advanced switch ON/OFF	0	Advanced switch time of Input Gain/Volume Tone/Fader/Loudness /Mixing		0	1	Advanced switch time of Mute	
Initial setup 2	02	LPF Phase	0	Subwoofer Output Select		0	Subwoofer LPF fc		
Initial setup 3	03	0	0	0	Loudness fo		0	0	1
Input Selector	05	Full-diff Type	0	0	Input selector				
Input gain	06	Mute ON/OFF	0	0	Input Gain				
Volume gain	20	Volume Gain / Attenuation							
Fader 1ch Front	28	Fader Gain / Attenuation							
Fader 2ch Front	29	Fader Gain / Attenuation							
Fader 1ch Rear	2A	Fader Gain / Attenuation							
Fader 2ch Rear	2B	Fader Gain / Attenuation							
Fader Subwoofer	2C	Fader Gain / Attenuation							
Mixing	30	Mixing Gain / Attenuation							
Bass setup	41	0	0	Bass fo		0	0	Bass Q	
Middle setup	44	0	0	Middle fo		0	0	Middle Q	
Treble setup	47	0	0	Treble fo		0	0	0	Treble Q
Bass gain	51	Bass Boost/Cut	0	0	Bass Gain				
Middle gain	54	Middle Boost/Cut	0	0	Middle Gain				
Treble gain	57	Treble Boost/Cut	0	0	Treble Gain				
Loudness Gain	75	0	Loudness Hicut		Loudness Gain				
System Reset	FE	1	0	0	0	0	0	0	1

 Advanced switch

Note

- In function changing of the hatching part, it works Advanced switch.
- Upon continuous data transfer, the Select Address is circulated by the automatic increment function, as shown below.

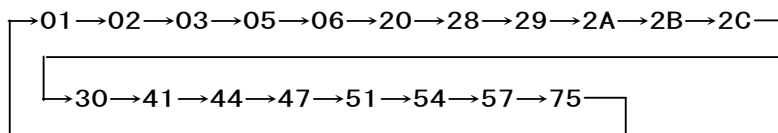

- For the function of input selector and subwoofer output select etc, it is not corresponded for advanced switch. Therefore, please apply mute on the side of a set when changes these setting.
- When using mute function of this IC at the time of changing input selector, please switch mute ON/OFF for waiting advanced-mute time.

BD37534FV

Items	Select Address (hex)	Data							
		MSB		Data				LSB	
		D7	D6	D5	D4	D3	D2	D1	D0
Initial setup 1	01	Advanced switch ON/OFF	0	Advanced switch time of Input Gain/Volume Tone/Fader/Loudness /Mixing		0	1	Advanced switch time of Mute	
Initial setup 2	02	LPF Phase	Level Meter RESET	Subwoofer Output Select		0	Subwoofer LPF fc		
Initial setup 3	03	0	0	0	Loudness fo		0	0	1
Input Selector	05	Full-diff Type	0	0	Input selector				
Input gain	06	Mute ON/OFF	0	0	Input Gain				
Volume gain	20	Volume Gain / Attenuation							
Fader 1ch Front	28	Fader Gain / Attenuation							
Fader 2ch Front	29	Fader Gain / Attenuation							
Fader 1ch Rear	2A	Fader Gain / Attenuation							
Fader 2ch Rear	2B	Fader Gain / Attenuation							
Fader Subwoofer	2C	Fader Gain / Attenuation							
Mixing	30	Mixing Gain / Attenuation							
Bass setup	41	0	0	Bass fo		0	0	Bass Q	
Middle setup	44	0	0	Middle fo		0	0	Middle Q	
Treble setup	47	0	0	Treble fo		0	0	0	Treble Q
Bass gain	51	Bass Boost/Cut	0	0	Bass Gain				
Middle gain	54	Middle Boost/Cut	0	0	Middle Gain				
Treble gain	57	Treble Boost/Cut	0	0	Treble Gain				
Loudness Gain	75	0	Loudness Hicut		Loudness Gain				
System Reset	FE	1	0	0	0	0	0	0	1

 Advanced switch

Note

- In function changing of the hatching part, it works Advanced switch.
- Upon continuous data transfer, the Select Address is circulated by the automatic increment function, as shown below.

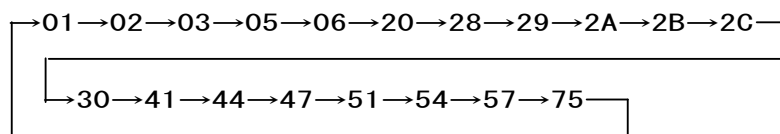

- For the function of input selector and subwoofer output select etc, it is not corresponded for advanced switch. Therefore, please apply mute on the side of a set when changes these setting.
- When using mute function of this IC at the time of changing input selector, please switch mute ON/OFF for waiting advanced-mute time.

Select address 01 (hex)

Time	Advanced switch time of Mute							LSB	
	D7	D6	D5	D4	D3	D2	D1	D0	
0.6msec	Advanced Switch ON/OFF	0	Advanced switch time of Input gain/Volume Tone/Fader/Loudness /Mixing		0	1	0	0	
1.0msec							0	1	
1.4msec							1	0	
3.2msec							1	1	

(Mixing is available only BD37533FV, BD37534FV)

Time	Advanced switch time of Input gain/Volume/Tone/Fader/Loudness/Mixing							LSB	
	D7	D6	D5	D4	D3	D2	D1	D0	
4.7 msec	Advanced Switch ON/OFF	0	0	0	0	1	Advanced switch Time of Mute		
7.1 msec			0	1					
11.2 msec			1	0					
14.4 msec			1	1					

(Mixing is available only BD37533FV, BD37534FV)

Mode	Advanced switch ON/OFF							LSB	
	D7	D6	D5	D4	D3	D2	D1	D0	
OFF	0	0	Advanced switch time of Input gain/Volume Tone/Fader/Loudness /Mixing		0	1	Advanced switch Time of Mute		
ON	1								

(Mixing is available only BD37533FV, BD37534FV)

Select address 02 (hex)

fc	Subwoofer LPF fc							LSB	
	D7	D6	D5	D4	D3	D2	D1	D0	
OFF	LPF Phase	Level Meter RESET	Subwoofer Output Select		0	0	0	0	
55Hz						0	0	1	
85Hz						0	1	0	
120Hz						0	1	1	
160Hz						1	0	0	
Prohibition						Other setting			

(Available only BD37532FV, BD37533FV, BD37534FV)

Mode	Subwoofer Output Select							LSB	
	D7	D6	D5	D4	D3	D2	D1	D0	
LPF	LPF Phase	Level Meter RESET	0	0	0	Subwoofer LPF fc			
Front			0	1					
Rear			1	0					
Prohibition			1	1					

Mode	Level Meter RESET							LSB	
	D7	D6	D5	D4	D3	D2	D1	D0	
HOLD	LPF Phase	0	Subwoofer output select		0	Subwoofer LPF fc			
RESET		1							

(Available only BD37534FV)

Phase	LPF Phase							LSB	
	D7	D6	D5	D4	D3	D2	D1	D0	
0°	0	Level Meter RESET	Subwoofer output select		0	Subwoofer LPF fc			
180°	1								

(Available only BD37532FV, BD37533FV, BD37534FV)

 : Initial Condition

Select address 03(hex)

f0	Loudness fo								
	MSB	D7	D6	D5	D4	D3	D2	D1	LSB
250Hz	0	0	0	0	0	0	0	0	1
400Hz				0	1				
800Hz				1	0				
Prohibition				1	1				

Select address 05(hex)

Mode	OUTF		Input Selector										
	OUTF1	OUTF2	MSB	D7	D6	D5	D4	D3	D2	D1	LSB		
A	A1	A2	Full-diff bias type select	0	0	0	0	0	0	0	0		
B	B1	B2				0	0	0	0	0	1	1	
C	C1	C2				0	0	0	0	1	1	0	
D single	DP1	DP2				0	0	0	0	1	0	1	
E1 single	EP1	EN1				0	1	0	0	1	1	0	
E2 single	EN2	EP2				0	1	0	0	1	1	1	
A diff	A1	B1				0	1	1	1	1	1	1	
C diff	B2	C2				1	0	0	0	0	0	0	
D diff	DP1	DP2				0	0	1	1	1	1	0	
E full diff	EP1	EP2				0	1	0	0	0	0	0	
Input SHORT						Other setting							
Prohibition						Other setting							

Input SHORT : The input impedance of each input terminal is lowered from 100kΩ (TYP) to 6 kΩ (TYP).  
(For quick charge of coupling capacitor)

Mode	Full-diff Bias Type Select								
	MSB	D7	D6	D5	D4	D3	D2	D1	LSB
Negative Input	0	0	0	0	0	Input Selector			
Bias	1								

Initial condition

Negative input type  
For Ground - isolation type)

Bias type  
For differential amplifier type

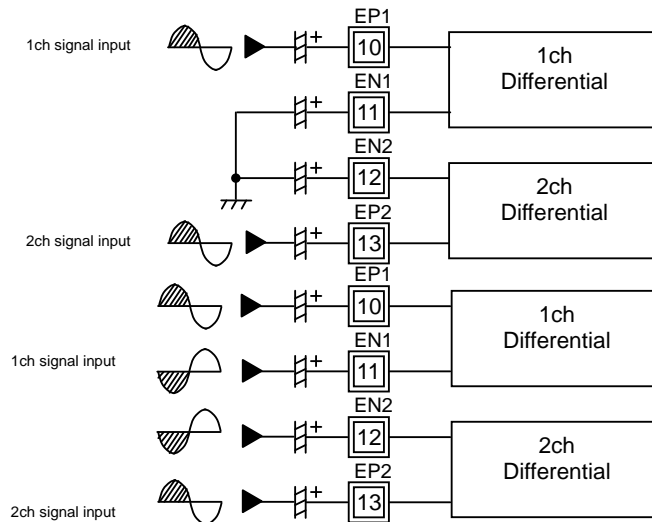

Select address 06 (hex)

Gain	MSB			Input Gain				LSB	
	D7	D6	D5	D4	D3	D2	D1	D0	
0dB	Mute ON/OFF	0	0	0	0	0	0	0	
1dB				0	0	0	0	1	
2dB				0	0	0	1	0	
3dB				0	0	0	1	1	
4dB				0	0	1	0	0	
5dB				0	0	1	0	1	
6dB				0	0	1	1	0	
7dB				0	0	1	1	1	
8dB				0	1	0	0	0	
9dB				0	1	0	0	1	
10dB				0	1	0	1	0	
11dB				0	1	0	1	1	
12dB				0	1	1	0	0	
13dB				0	1	1	0	1	
14dB				0	1	1	1	0	
15dB				0	1	1	1	1	
16dB				1	0	0	0	0	
17dB				1	0	0	0	1	
18dB				1	0	0	1	0	
19dB				1	0	0	1	1	
20dB	1	0	1	0	0				
Prohibition	1	1	0	1	1				
	:	:	:	:	:				
	1	1	1	1	1				

Mode	MSB			Mute ON/OFF				LSB	
	D7	D6	D5	D4	D3	D2	D1	D0	
OFF	0	0	0	Input Gain					
ON	1								

 : Initial condition

Select address 20, 28, 29, 2A, 2B, 2C (hex)

Gain & ATT	MSB Vol. Fader Gain / Attenuation							LSB
	D7	D6	D5	D4	D3	D2	D1	D0
Prohibition	0	0	0	0	0	0	0	0
	0	0	0	0	0	0	0	1
	:	:	:	:	:	:	:	:
	0	1	1	1	0	0	0	0
15dB	0	1	1	1	0	0	0	1
14dB	0	1	1	1	0	0	1	0
13dB	0	1	1	1	0	0	1	1
:	:	:	:	:	:	:	:	:
-77dB	1	1	0	0	1	1	0	1
-78dB	1	1	0	0	1	1	1	0
-79dB	1	1	0	0	1	1	1	1
Prohibition	1	1	0	1	0	0	0	0
	:	:	:	:	:	:	:	:
	1	1	1	1	1	1	1	0
-∞dB	1	1	1	1	1	1	1	1

(About BD37531FV, only 0dB~-∞dB are available)

Select address 30(hex)

Gain & ATT	MSB Mixing Gain / Attenuation							LSB
	D7	D6	D5	D4	D3	D2	D1	D0
Prohibition	0	0	0	0	0	0	0	0
	0	0	0	0	0	0	0	1
	:	:	:	:	:	:	:	:
	0	1	1	1	1	0	0	0
7dB	0	1	1	1	1	0	0	1
6dB	0	1	1	1	1	0	1	0
5dB	0	1	1	1	1	0	1	1
:	:	:	:	:	:	:	:	:
-77dB	1	1	0	0	1	1	0	1
-78dB	1	1	0	0	1	1	1	0
-79dB	1	1	0	0	1	1	1	1
Prohibition	1	1	0	1	0	0	0	0
	:	:	:	:	:	:	:	:
	1	1	1	1	1	1	1	0
MIX OFF	1	1	1	1	1	1	1	1

(Available only BD37533FV, BD37534FV)

 : Initial condition

Select address 41 (hex)

Q factor	MSB		Bass Q factor				LSB	
	D7	D6	D5	D4	D3	D2	D1	D0
0.5	0	0	Bass fo		0	0	0	0
1.0							0	1
1.5							1	0
2.0							1	1

fo	MSB		Bass fo				LSB	
	D7	D6	D5	D4	D3	D2	D1	D0
60Hz	0	0	0	0	0	0	Bass Q factor	
80Hz			0	1				
100Hz			1	0				
120Hz			1	1				

Select address 44 (hex)

Q factor	MSB		Middle Q factor				LSB	
	D7	D6	D5	D4	D3	D2	D1	D0
0.75	0	0	Middle fo		0	0	0	0
1.0							0	1
1.25							1	0
1.5							1	1

fo	MSB		Middle fo				LSB	
	D7	D6	D5	D4	D3	D2	D1	D0
500Hz	0	0	0	0	0	0	Middle Q factor	
1kHz			0	1				
1.5kHz			1	0				
2.5kHz			1	1				

Select address 47 (hex)

Q factor	MSB		Treble Q factor				LSB	
	D7	D6	D5	D4	D3	D2	D1	D0
0.75	0	0	Treble fo		0	0	0	0
1.25								1

fo	MSB		Treble fo				LSB		
	D7	D6	D5	D4	D3	D2	D1	D0	
7.5kHz	0	0	0	0	0	0	0	Treble Q factor	
10kHz			0	1					
12.5kHz			1	0					
15kHz			1	1					

 : Initial condition

Select address 51, 54, 57 (hex)

Gain	Bass/Middle/Treble Gain							LSB
	D7	D6	D5	D4	D3	D2	D1	D0
0dB				0	0	0	0	0
1dB				0	0	0	0	1
2dB				0	0	0	1	0
3dB				0	0	0	1	1
4dB				0	0	1	0	0
5dB				0	0	1	0	1
6dB				0	0	1	1	0
7dB				0	0	1	1	1
8dB				0	1	0	0	0
9dB				0	1	0	0	1
10dB	Bass/ Middle/ Treble Boost /cut	0	0	0	1	0	1	0
11dB				0	1	0	1	1
12dB				0	1	1	0	0
13dB				0	1	1	0	1
14dB				0	1	1	1	0
15dB				0	1	1	1	1
16dB				1	0	0	0	0
17dB				1	0	0	0	1
18dB				1	0	0	1	0
19dB				1	0	0	1	1
20dB				1	0	1	0	0
Prohibition				1	0	1	0	1
				:	:	:	:	:
				1	1	1	1	0
			1	1	1	1	1	

Mode	Bass/Middle/Treble Boost/Cut							LSB
	D7	D6	D5	D4	D3	D2	D1	D0
Boost	0	0	0	Bass/Middle/Treble Gain				
Cut	1							

 : Initial condition



Select address 75 (hex)

Mode	Loudness Hicut					LSB		
	D7	D6	D5	D4	D3	D2	D1	D0
Hicut1	0	0	0	Loudness Gain				
Hicut2		0	1					
Hicut3		1	0					
Hicut4		1	1					

Gain	Loudness Gain					LSB		
	D7	D6	D5	D4	D3	D2	D1	D0
0dB	0	Loudness Hicut		0	0	0	0	0
1dB				0	0	0	0	1
2dB				0	0	0	1	0
3dB				0	0	0	1	1
4dB				0	0	1	0	0
5dB				0	0	1	0	1
6dB				0	0	1	1	0
7dB				0	0	1	1	1
8dB				0	1	0	0	0
9dB				0	1	0	0	1
10dB				0	1	0	1	0
11dB				0	1	0	1	1
12dB				0	1	1	0	0
13dB				0	1	1	0	1
14dB				0	1	1	1	0
15dB				0	1	1	1	1
16dB				1	0	0	0	0
17dB				1	0	0	0	1
18dB				1	0	0	1	0
19dB				1	0	0	1	1
20dB	1	0	1	0	0			
Prohibition	:	:	:	:	:			
	1	1	1	1	1			

 : Initial condition

(6) About power on reset

At on of supply voltage circuit made initialization inside IC is built-in. Please send data to all address as initial data at supply voltage on. And please supply mute at set side until this initial data is sent.

Item	Symbol	Limit			Unit	Condition
		Min.	Typ.	Max.		
Rise time of VCC	Trise	33	—	—	usec	VCC rise time from 0V to 5V
VCC voltage of release power on reset	Vpor	—	4.1	—	V	

(7) About external compulsory mute terminal

Mute is possible forcibly than the outside after input again department, by the setting of the MUTE terminal.

Mute Voltage Condition	Mode
GND~1.0V	MUTE ON
2.3V~VCC	MUTE OFF

Establish the voltage of MUTE in the condition to have been defined.

Volume / Fader volume / Mixing attenuation of the details

(dB)	D7	D6	D5	D4	D3	D2	D1	D0	(dB)	D7	D6	D5	D4	D3	D2	D1	D0
+15	0	1	1	1	0	0	0	1	-33	1	0	1	0	0	0	0	1
+14	0	1	1	1	0	0	1	0	-34	1	0	1	0	0	0	1	0
+13	0	1	1	1	0	0	1	1	-35	1	0	1	0	0	0	1	1
+12	0	1	1	1	0	1	0	0	-36	1	0	1	0	0	1	0	0
+11	0	1	1	1	0	1	0	1	-37	1	0	1	0	0	1	0	1
+10	0	1	1	1	0	1	1	0	-38	1	0	1	0	0	1	1	0
+9	0	1	1	1	0	1	1	1	-39	1	0	1	0	0	1	1	1
+8	0	1	1	1	1	0	0	0	-40	1	0	1	0	1	0	0	0
+7	0	1	1	1	1	0	0	1	-41	1	0	1	0	1	0	0	1
+6	0	1	1	1	1	0	1	0	-42	1	0	1	0	1	0	1	0
+5	0	1	1	1	1	0	1	1	-43	1	0	1	0	1	0	1	1
+4	0	1	1	1	1	1	0	0	-44	1	0	1	0	1	1	0	0
+3	0	1	1	1	1	1	0	1	-45	1	0	1	0	1	1	0	1
+2	0	1	1	1	1	1	1	0	-46	1	0	1	0	1	1	1	0
+1	0	1	1	1	1	1	1	1	-47	1	0	1	0	1	1	1	1
0	1	0	0	0	0	0	0	0	-48	1	0	1	1	0	0	0	0
-1	1	0	0	0	0	0	0	1	-49	1	0	1	1	0	0	0	1
-2	1	0	0	0	0	0	1	0	-50	1	0	1	1	0	0	1	0
-3	1	0	0	0	0	0	1	1	-51	1	0	1	1	0	0	1	1
-4	1	0	0	0	0	1	0	0	-52	1	0	1	1	0	1	0	0
-5	1	0	0	0	0	1	0	1	-53	1	0	1	1	0	1	0	1
-6	1	0	0	0	0	1	1	0	-54	1	0	1	1	0	1	1	0
-7	1	0	0	0	0	1	1	1	-55	1	0	1	1	0	1	1	1
-8	1	0	0	0	1	0	0	0	-56	1	0	1	1	1	0	0	0
-9	1	0	0	0	1	0	0	1	-57	1	0	1	1	1	0	0	1
-10	1	0	0	0	1	0	1	0	-58	1	0	1	1	1	0	1	0
-11	1	0	0	0	1	0	1	1	-59	1	0	1	1	1	0	1	1
-12	1	0	0	0	1	1	0	0	-60	1	0	1	1	1	1	0	0
-13	1	0	0	0	1	1	0	1	-61	1	0	1	1	1	1	0	1
-14	1	0	0	0	1	1	1	0	-62	1	0	1	1	1	1	1	0
-15	1	0	0	0	1	1	1	1	-63	1	0	1	1	1	1	1	1
-16	1	0	0	1	0	0	0	0	-64	1	1	0	0	0	0	0	0
-17	1	0	0	1	0	0	0	1	-65	1	1	0	0	0	0	0	1
-18	1	0	0	1	0	0	1	0	-66	1	1	0	0	0	0	1	0
-19	1	0	0	1	0	0	1	1	-67	1	1	0	0	0	0	1	1
-20	1	0	0	1	0	1	0	0	-68	1	1	0	0	0	1	0	0
-21	1	0	0	1	0	1	0	1	-69	1	1	0	0	0	1	0	1
-22	1	0	0	1	0	1	1	0	-70	1	1	0	0	0	1	1	0
-23	1	0	0	1	0	1	1	1	-71	1	1	0	0	0	1	1	1
-24	1	0	0	1	1	0	0	0	-72	1	1	0	0	1	0	0	0
-25	1	0	0	1	1	0	0	1	-73	1	1	0	0	1	0	0	1
-26	1	0	0	1	1	0	1	0	-74	1	1	0	0	1	0	1	0
-27	1	0	0	1	1	0	1	1	-75	1	1	0	0	1	0	1	1
-28	1	0	0	1	1	1	0	0	-76	1	1	0	0	1	1	0	0
-29	1	0	0	1	1	1	0	1	-77	1	1	0	0	1	1	0	1
-30	1	0	0	1	1	1	1	0	-78	1	1	0	0	1	1	1	0
-31	1	0	0	1	1	1	1	1	-79	1	1	0	0	1	1	1	1
-32	1	0	1	0	0	0	0	0	-∞	1	1	1	1	1	1	1	1

About BD37531FV, Fader Volume only 0dB~-∞dB are available.

Mixing is available only BD37533FV, BD37534FV. Adjustable range is +7dB~-∞dB.

: Initial condition

About Level meter (available only BD37534FV)

- (1) The operation of circuit  
 Level meter is a function which gives DC voltage proportional to the size of signal of sound. It detects the peak level of signal and keeps the peak level, so that it is possible to monitor the size of signal by resetting DC voltage kept with suitable interval.
- (2) The way to reset level meter output  
 Please send reset data through I<sup>2</sup>C BUS  
 When reset output of level meter : Send D6 = " 1 " of select address 02(hex).  
 When cancel of output reset of level meter (HOLD) ... → Send D6 = " 0 " of select address 02(hex).
- (3) The settings about period of reset  
 Peak hold operation will start after HOLD data is transmitted. Set the WAIT time after HOLD data transmission according to the frequency bandwidth detected.  
 WAIT time must be set to a minimum of one cycle over the detected frequency bandwidth.  
 Ex) Detected frequency bandwidth is above 40Hz, 『40Hz = 25ms = WAIT time』

Transmission Example by I<sup>2</sup>C BUS

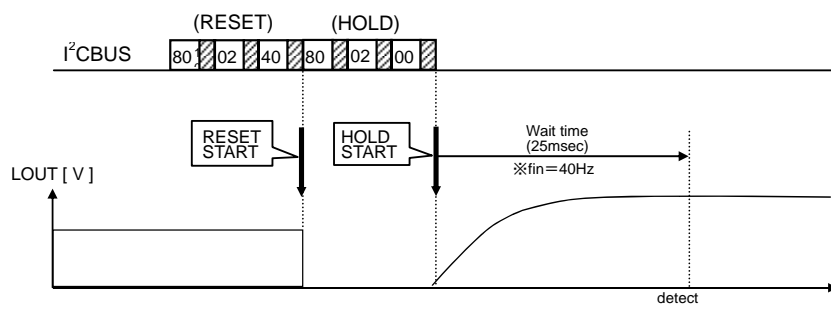

● Application circuit

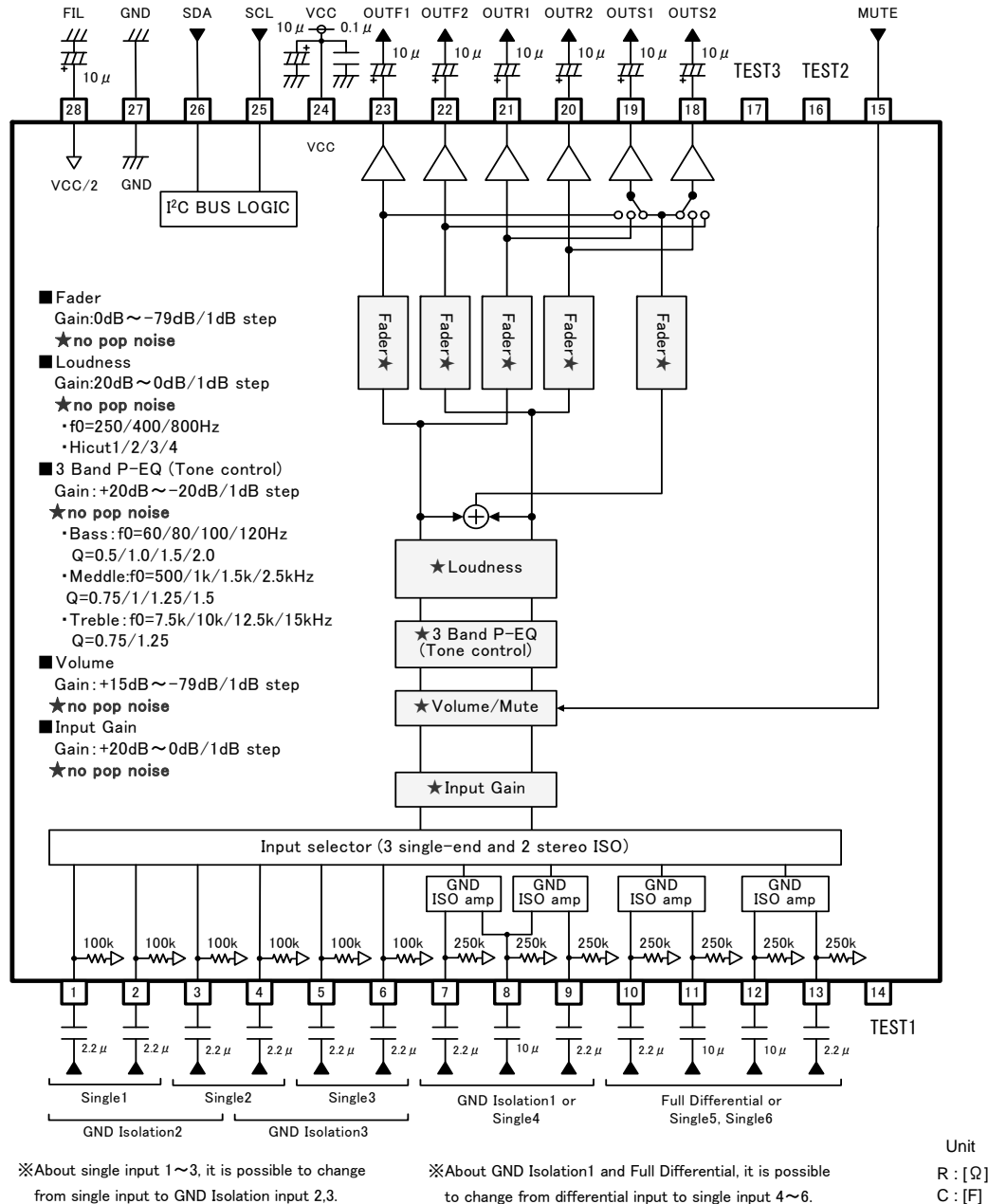

Fig. 28 BD37531FV

**Notes on wiring**

- ① Please connect the decoupling capacitor of a power supply in the shortest distance as much as possible to GND.
- ② Lines of GND shall be one-point connected.
- ③ Wiring pattern of Digital shall be away from that of analog unit and cross-talk shall not be acceptable.
- ④ Lines of SCL and SDA of I<sup>2</sup>C BUS shall not be parallel if possible. The lines shall be shielded, if they are adjacent to each other.
- ⑤ Lines of analog input shall not be parallel if possible. The lines shall be shielded, if they are adjacent to each other.
- ⑥ About TEST pin(14, 16, 17pin), please use with OPEN.

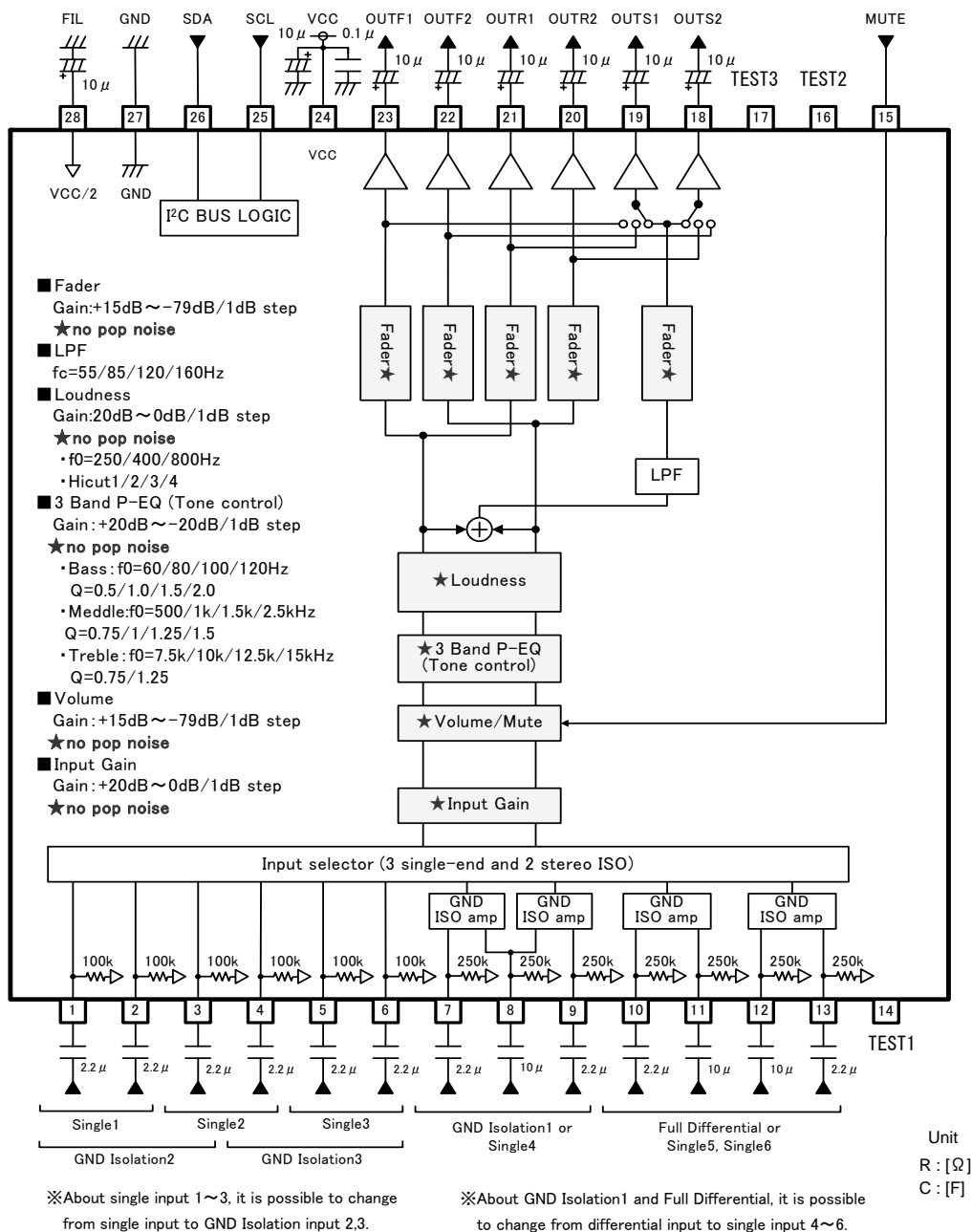

Fig. 29 BD37532FV

**Notes on wiring**

- ① Please connect the decoupling capacitor of a power supply in the shortest distance as much as possible to GND.
- ② Lines of GND shall be one-point connected.
- ③ Wiring pattern of Digital shall be away from that of analog unit and cross-talk shall not be acceptable.
- ④ Lines of SCL and SDA of I<sup>2</sup>C BUS shall not be parallel if possible. The lines shall be shielded, if they are adjacent to each other.
- ⑤ Lines of analog input shall not be parallel if possible. The lines shall be shielded, if they are adjacent to each other.
- ⑥ About TEST pin(14, 15, 16pin), please use with OPEN.

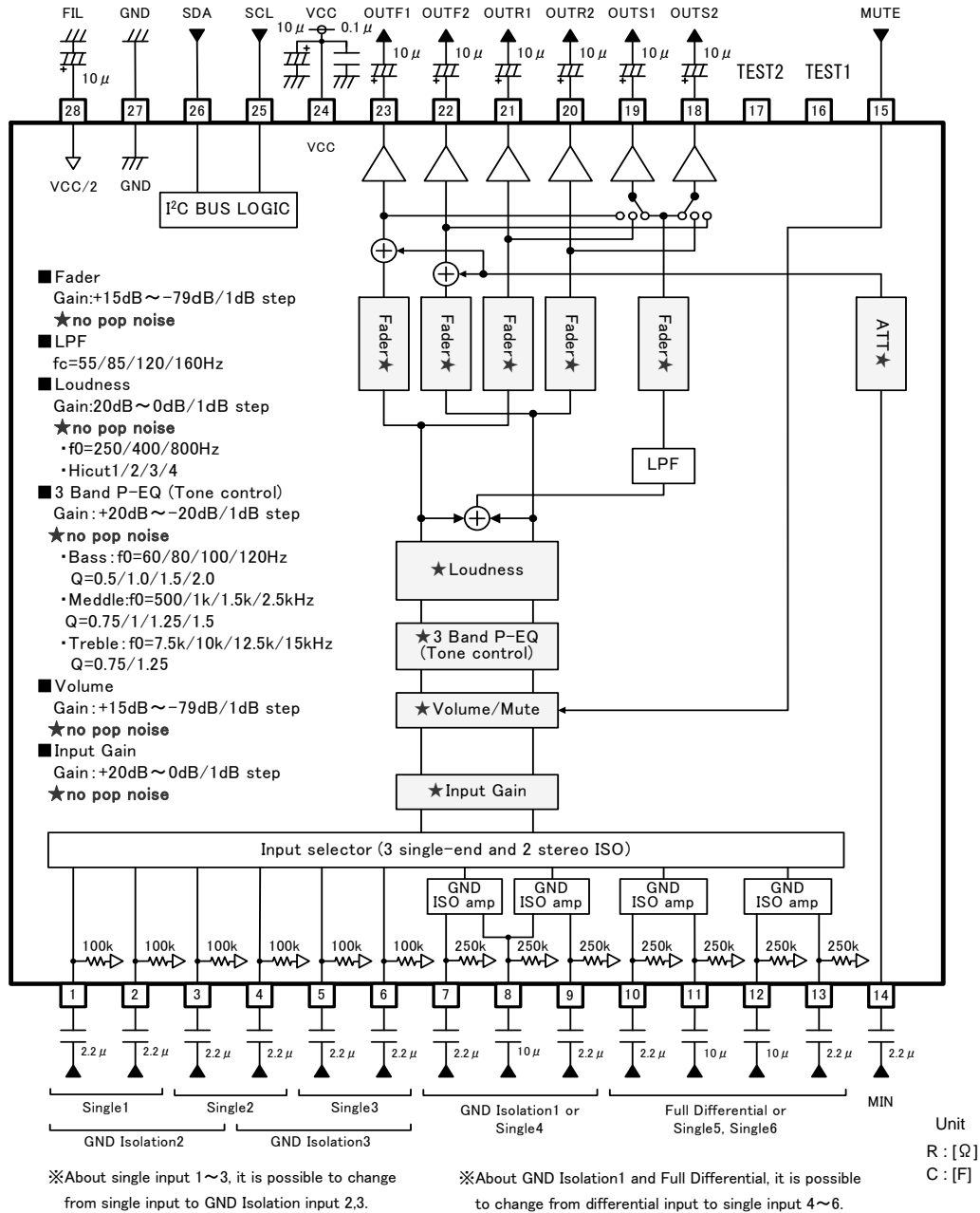

Fig. 30 BD37533FV

**Notes on wiring**

- ① Please connect the decoupling capacitor of a power supply in the shortest distance as much as possible to GND.
- ② Lines of GND shall be one-point connected.
- ③ Wiring pattern of Digital shall be away from that of analog unit and cross-talk shall not be acceptable.
- ④ Lines of SCL and SDA of I<sup>2</sup>C BUS shall not be parallel if possible. The lines shall be shielded, if they are adjacent to each other.
- ⑤ Lines of analog input shall not be parallel if possible. The lines shall be shielded, if they are adjacent to each other.
- ⑥ About TEST pin(16,17pin), please use with OPEN.

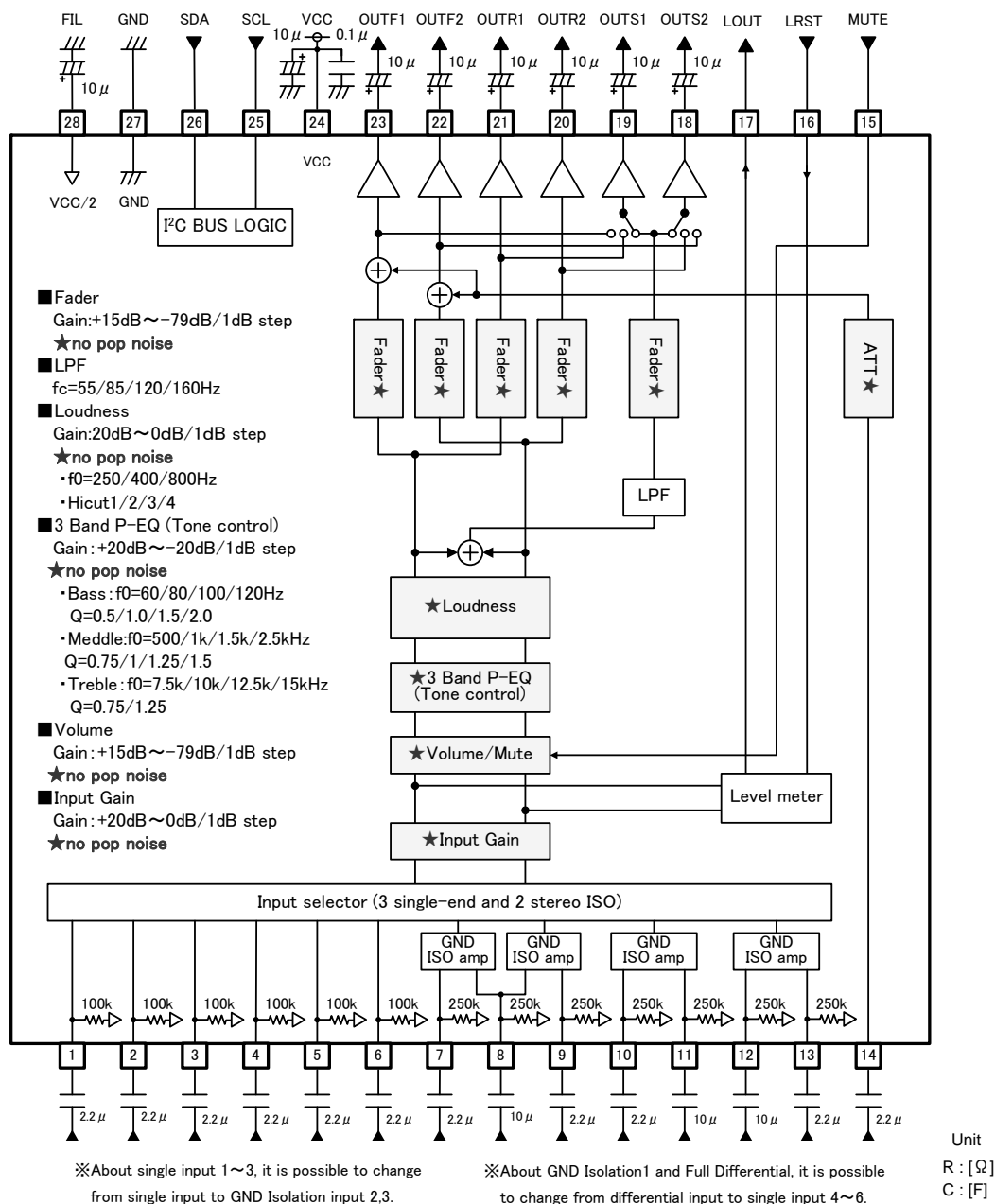

Fig. 31 BD37534FV

- Notes on wiring**
- ① Please connect the decoupling capacitor of a power supply in the shortest distance as much as possible to GND.
  - ② Lines of GND shall be one-point connected.
  - ③ Wiring pattern of Digital shall be away from that of analog unit and cross-talk shall not be acceptable.
  - ④ Lines of SCL and SDA of I<sup>2</sup>C BUS shall not be parallel if possible. The lines shall be shielded, if they are adjacent to each other.
  - ⑤ Lines of analog input shall not be parallel if possible. The lines shall be shielded, if they are adjacent to each other.

● Interfaces

Terminal No.	Terminal Name	Terminal Voltage	Equivalent Circuit	Terminal Description
1 2 3 4 5 6	A1 A2 B1 B2 C1 C2	4.25		A terminal for signal input. The input impedance is 100kΩ (typ).
7 8 9 10 11 12 13	DP1 DN DP2 EP1 EN1 EN2 EP2	4.25		Input terminal available to single/Differential mode. The input impedance is 250kΩ (typ).
15	MUTE	—		A terminal for external compulsory mute. If terminal voltage is High level, the mute is off. And if the terminal voltage is Low level, the mute is on.
18 19 20 21 22 23	OUTS2 OUTS1 OUTR2 OUTR1 OUTF2 OUTF1	4.25		A terminal for fader and Subwoofer output.
17	LOUT	0~3.3		A terminal for level meter output (BD37534FV) Output impedance is 10kΩ (typ).

The figure in the pin explanation and input/output equivalent circuit is reference value, it doesn't guarantee the value.



Terminal No.	Terminal Name	Terminal Voltage	Equivalent Circuit	Terminal Description
24	VCC	8.5		Power supply terminal.
25	SCL	—		A terminal for clock input of I <sup>2</sup> C BUS communication.
26	SDA	—		A terminal for data input of I <sup>2</sup> C BUS communication.
27	GND	0		Ground terminal.
28	FIL	4.25		Voltage for reference bias of analog signal system. The simple precharge circuit and simple discharge circuit for an external capacitor are built in.
14	MIN	4.25		A terminal for signal input (BD37533FV, BD37534FV) The input impedance is 27kΩ (typ).
14 16 17	TEST	—		TEST terminal (BD37531FV, BD37532FV, BD37533FV) About BD37531FV and BD37532FV, 14, 16, 17pin are TEST Pin. About BD37533FV, 16, 17pin are TEST Pin.

The figure in the pin explanation and input/output equivalent circuit is reference value, it doesn't guarantee the value.

## ●Notes for use

### 1. Absolute maximum rating voltage

When it impressed the voltage on VCC more than the absolute maximum rating voltage, circuit currents increase rapidly, and there is absolutely a case to reach characteristic deterioration and destruction of a device. In particular in a surge examination of a set, when it is expected the impressing surge at VCC terminal (24pin), please do not impress the large and over the absolute maximum rating voltage (including a operating voltage + surge ingredient (around 14V)).

### 2. About a signal input part

#### 1) About constant set up of input coupling capacitor

In the signal input terminal, the constant setting of input coupling capacitor C(F) be sufficient input impedance  $R_{IN}(\Omega)$  inside IC and please decide. The first HPF characteristic of RC is composed.

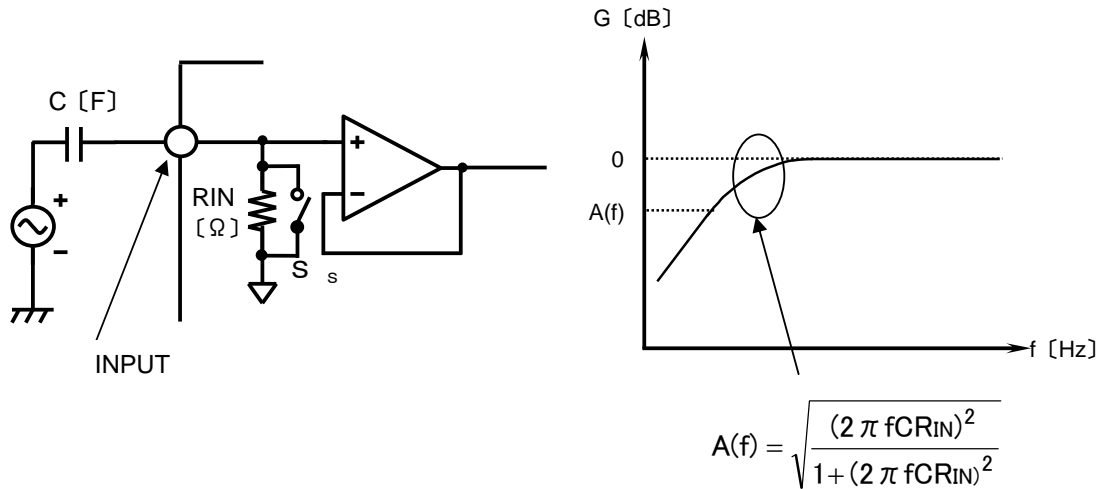

#### 2) About the input selector SHORT

SHORT mode is the command which makes switch  $S_{SH}$  =ON an input selector part and input impedance  $R_{IN}$  of all terminals, and makes resistance small. Switch  $S_{SH}$  is OFF when not choosing a SHORT command. A constant time becomes small at the time of this command twisting to the resistance inside the capacitor connected outside and LSI. The charge time of a capacitor becomes short. Since SHORT mode turns ON the switch of  $S_{SH}$  and makes it low impedance, please use it at the time of a non-signal.

### 3. About Mute terminal(15pin) when power supply is off

Any voltage shall not be supplied to Mute terminal (15pin) when power-supply is off. Please insert a resistor (about 2.2k $\Omega$ ) to Mute terminal in series, if voltage is supplied to mute terminal in case. (Please refer Application Circuit Diagram.)

### 4. About TEST Pin

About TEST Pin, please use with OPEN.

About BD37531FV and BD37532FV, 14,16,17pin are TEST Pin. About BD37533FV, 16,17pin are TEST Pin.

5. About Mixing (BD3753FV, BD37534FV)

• About specification of Fader  $-\infty$  at Mixing ON.

Mixed signal is added to Main signal after Fader Gain(+15~-79dB) like the following figure. When Fader is made a set up in  $-\infty$ , the signal after a Mixing signal is added is done with MUTE. Because the  $-\infty$  circuit of Fader is in the step after the addition circuit.

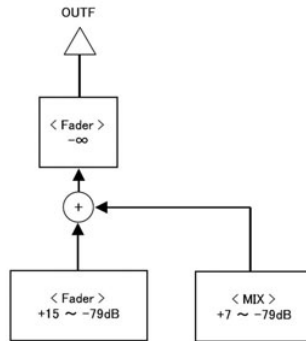
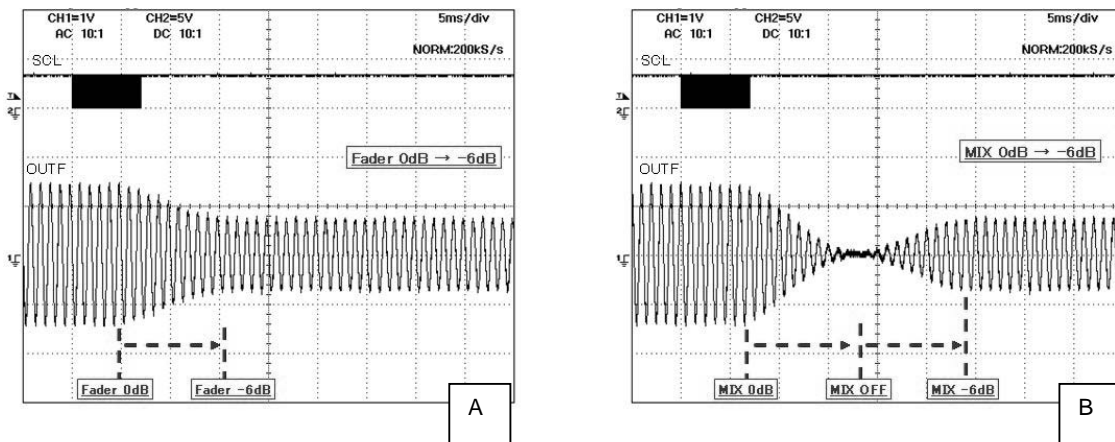

Fig. 32 About Front Fader and Mixing

• About advanced switching of Mixing Gain/ATT

When advanced switching of Mixing Gain/ATT works, Mixing becomes the switching movement that it passed through state of Mixing OFF like B (A present setup of Mixing Gain/ATT → Mixing OFF → A target setup of Mixing Gain/ATT).



Fader Gain/ATT 0dB → -6dB advanced switching

Mixing Gain/ATT 0dB → -6dB advanced switching

Fig. 33 Advanced switching movement when Mixing Gain/ATT is changed

● Thermal Derating Curve

About the thermal design by the IC

Characteristics of an IC have a great deal to do with the temperature at which it is used, and exceeding absolute maximum ratings may degrade and destroy elements. Careful consideration must be given to the heat of the IC from the two standpoints of immediate damage and long-term reliability of operation.

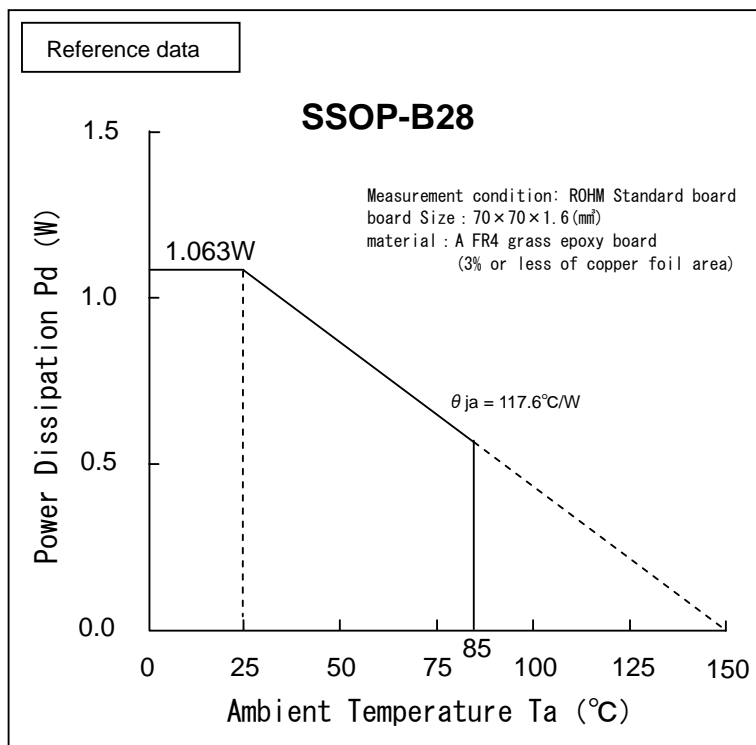

Fig.34 Temperature Derating Curve

Note) Values are actual measurements and are not guaranteed.

Power dissipation values vary according to the board on which the IC is mounted.

● Ordering part number

B	D
---	---

Part No.

3	7	5	3	1
---	---	---	---	---

Part No.

37531  
37532  
37533  
37534

F	V
---	---

Package

FV : SSOP-B28

E	2
---	---

Packaging and forming specification

E2: Embossed tape and reel

SSOP-B28

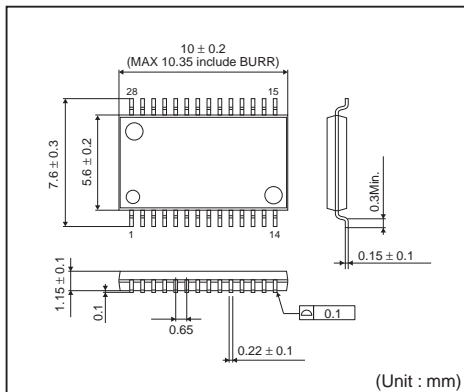

<Tape and Reel information>

Tape	Embossed carrier tape
Quantity	2000pcs
Direction of feed	E2 ( The direction is the 1pin of product is at the upper left when you hold reel on the left hand and you pull out the tape on the right hand )

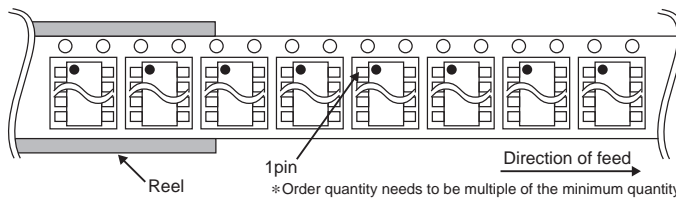

## Notes

No copying or reproduction of this document, in part or in whole, is permitted without the consent of ROHM Co.,Ltd.

The content specified herein is subject to change for improvement without notice.

The content specified herein is for the purpose of introducing ROHM's products (hereinafter "Products"). If you wish to use any such Product, please be sure to refer to the specifications, which can be obtained from ROHM upon request.

Examples of application circuits, circuit constants and any other information contained herein illustrate the standard usage and operations of the Products. The peripheral conditions must be taken into account when designing circuits for mass production.

Great care was taken in ensuring the accuracy of the information specified in this document. However, should you incur any damage arising from any inaccuracy or misprint of such information, ROHM shall bear no responsibility for such damage.

The technical information specified herein is intended only to show the typical functions of and examples of application circuits for the Products. ROHM does not grant you, explicitly or implicitly, any license to use or exercise intellectual property or other rights held by ROHM and other parties. ROHM shall bear no responsibility whatsoever for any dispute arising from the use of such technical information.

The Products specified in this document are intended to be used with general-use electronic equipment or devices (such as audio visual equipment, office-automation equipment, communication devices, electronic appliances and amusement devices).

The Products specified in this document are not designed to be radiation tolerant.

While ROHM always makes efforts to enhance the quality and reliability of its Products, a Product may fail or malfunction for a variety of reasons.

Please be sure to implement in your equipment using the Products safety measures to guard against the possibility of physical injury, fire or any other damage caused in the event of the failure of any Product, such as derating, redundancy, fire control and fail-safe designs. ROHM shall bear no responsibility whatsoever for your use of any Product outside of the prescribed scope or not in accordance with the instruction manual.

The Products are not designed or manufactured to be used with any equipment, device or system which requires an extremely high level of reliability the failure or malfunction of which may result in a direct threat to human life or create a risk of human injury (such as a medical instrument, transportation equipment, aerospace machinery, nuclear-reactor controller, fuel-controller or other safety device). ROHM shall bear no responsibility in any way for use of any of the Products for the above special purposes. If a Product is intended to be used for any such special purpose, please contact a ROHM sales representative before purchasing.

If you intend to export or ship overseas any Product or technology specified herein that may be controlled under the Foreign Exchange and the Foreign Trade Law, you will be required to obtain a license or permit under the Law.



Thank you for your accessing to ROHM product informations.  
More detail product informations and catalogs are available, please contact us.

### ROHM Customer Support System

<http://www.rohm.com/contact/>