

PHOTO REFLECTOR

■ GENERAL DESCRIPTION

The NJL5181K/83K can be soldering by reflow-method. This is super miniature mold photo reflector.

■ FEATURES

- Thin package type.
(It is the same size of NJL5161K/63K)
- Soldering to be done within twice under recommended reflow method.

■ APPLICATIONS

- Reel rotation sensor
- Tape end sensor
- Paper mark sensor
- Opto-electronics SW

■ ABSOLUTE MAXIMUM RATINGS (Ta=25°C)

PARAMETER	SYMBOL	RATINGS	UNIT
Emitter			
Forward Current (Continuous)	I _F	50	mA
Pulse Forward Current	I _{FP}	500(note 1)	mA
Reverse Voltage (Continuous)	V _R	6	V
Power Dissipation	P _D	75	mW
Detector			
Collector-Emitter Voltage	V _{CEO}	25	V
Emitter-Collector Voltage	V _{ECO}	6	V
Collector Current	I _C	20	mA
Collector Dissipation	P _C	75	mW
Coupler			
Total Power Dissipation	P _{tot}	100	mW
Operating Temperature	T _{opr}	-20~+90	°C
Storage Temperature	T _{stg}	-30~+100	°C
Soldering Temperature	T _{sol}	260	°C
		(10sec. 1.5mm from body)	

(note 1) Pulse Width ≤ 10μs, Duty Ratio 0.01

■ ELECTRO-OPTICAL CHARACTERISTICS (Ta=25°C)

PARAMETER	SYMBOL	TEST CONDITION	MIN.	TYP.	MAX.	UNIT
Emitter						
Forward Voltage	V _F	I _F = 4mA	—	—	1.2	V
Reverse Current	I _R	V _R = 6V	—	—	10	μA
Capacitance	C _t	V _R = 0V, f = 1MHz	—	25	—	pF
Detector						
Dark Current	I _{CEO}	V _{CE} = 20V	—	—	100	nA
Collector-Emitter Voltage	V _{CEO}	I _C = 100μA	25	—	—	V
Coupled						
Output Current	I _O	I _F = 4mA, V _{CE} = 2V, d = 0.7mm	21	—	125	μA
Operating Dark Current	I _{CEO_D}	I _F = 4mA, V _{CE} = 2V	—	—	100	nA
Rise Time	t _r	I _F = 4mA, V _{CE} = 2V, R _L = 1KΩ, d = 0.7mm	—	20	—	μs
Fall Time	t _f	I _F = 4mA, V _{CE} = 2V, R _L = 1KΩ, d = 0.7mm	—	20	—	μs

■ RANK OF OUTPUT CURRENT

RANK	A	B	C
I _O (μA)	60~125	35~73	21~43

■ OUTLINE (typ.) Unit:mm

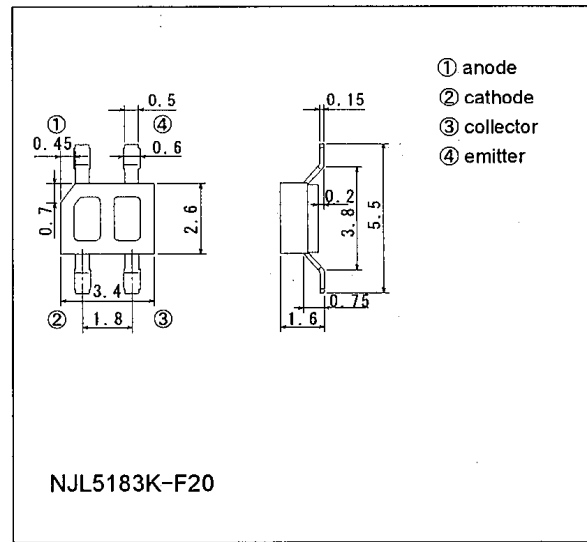
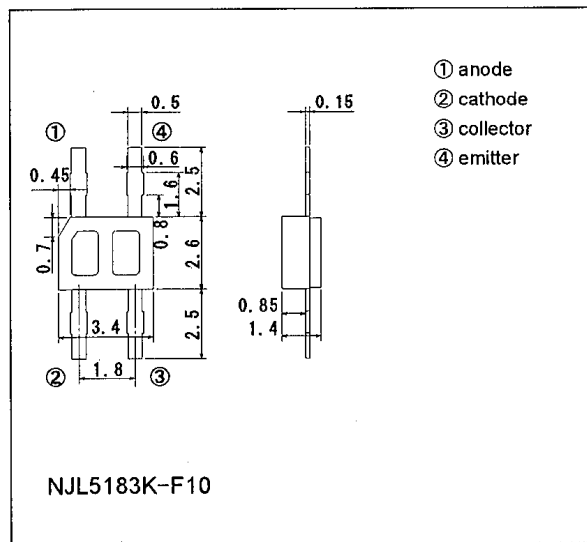
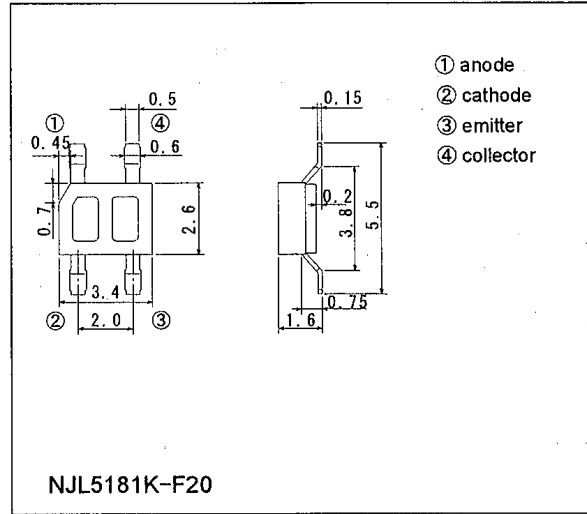
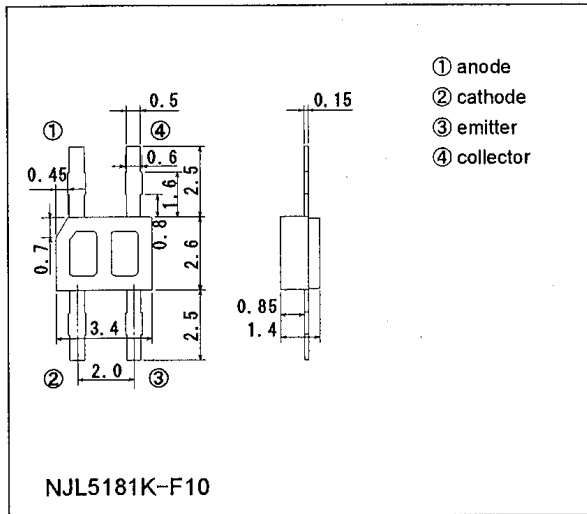

2

2

MEASURING SPECIFICATION FOR OUTPUT CURRENT

The Output current can be measured when reflected at the aluminum evaporation mirror.

MEASURING CIRCUIT FOR OPERATING DARK CURRENT

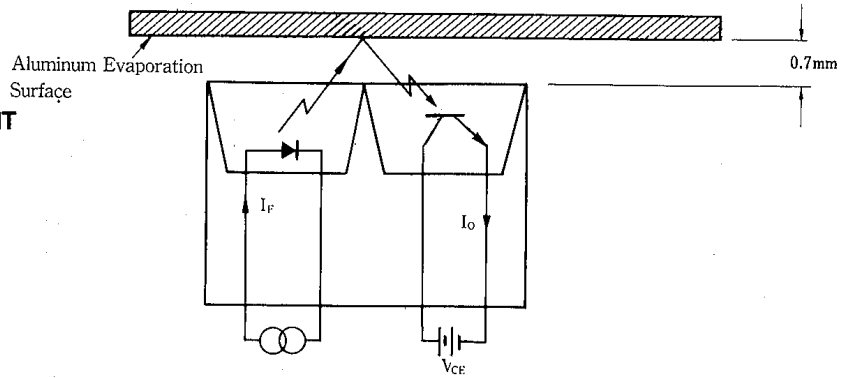
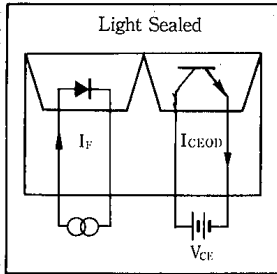

MEASURING CIRCUIT FOR RESPONSE TIME

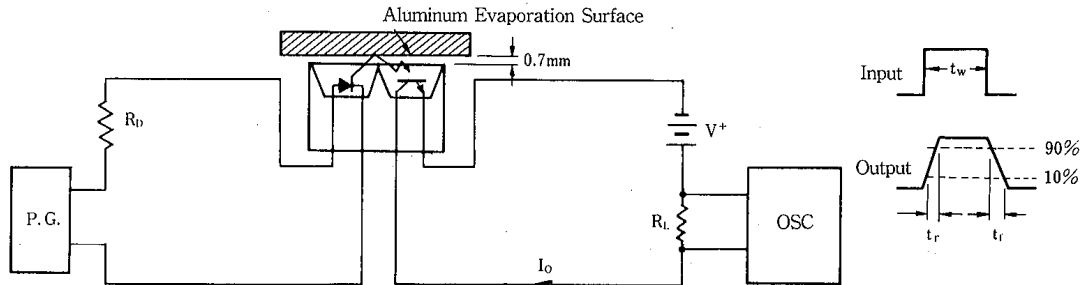

MAXIMUM RATING CURVES

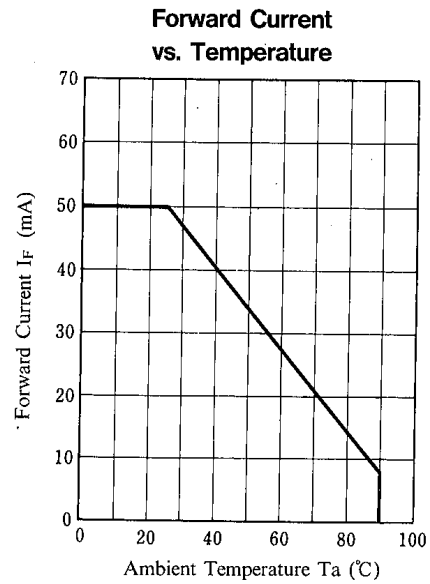
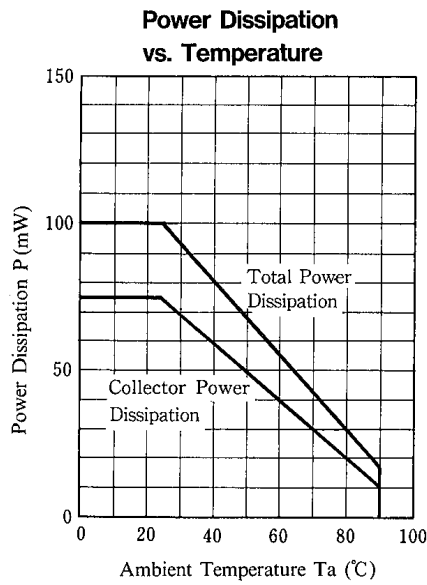

Pulse Forward Current vs. Duty Ratio

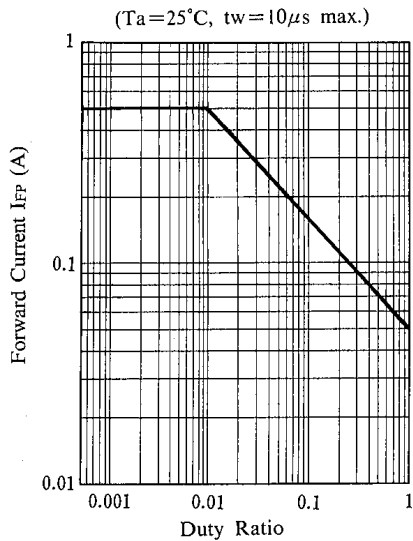

Pulse Width vs. Forward Current

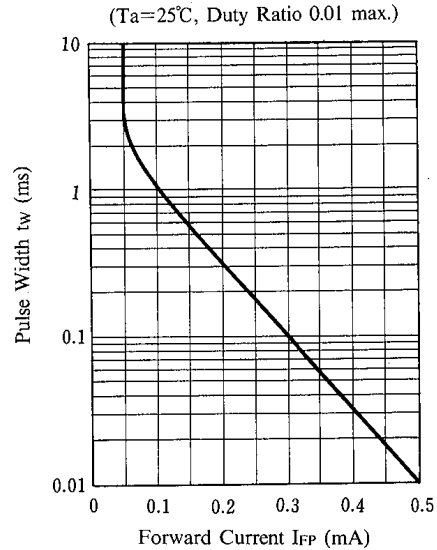

2

■ **TYPICAL CHARACTERISTICS**

Forward Current vs. Forward Voltage

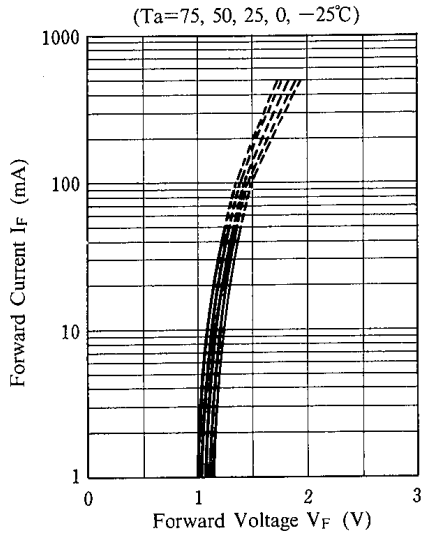

Dark Current vs. Temperature

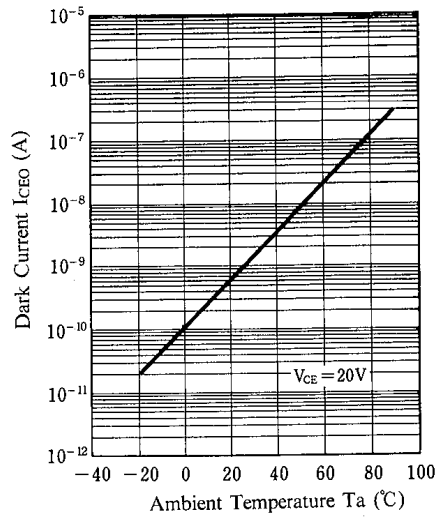

Output Current vs. Forward Current ($T_a=25^\circ\text{C}$)

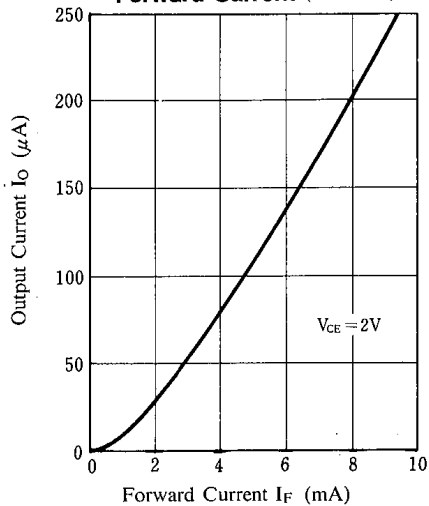

Output Current vs. Temperature

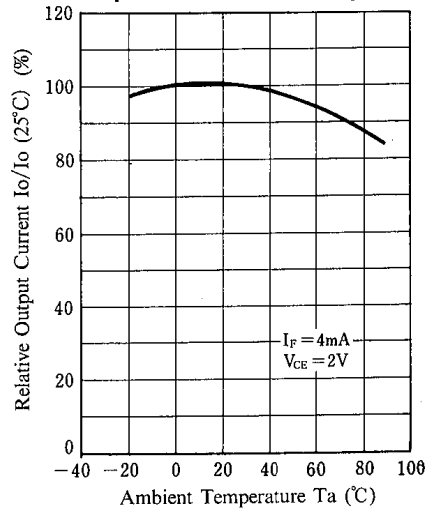

2

Operating Dark Current vs. Temperature

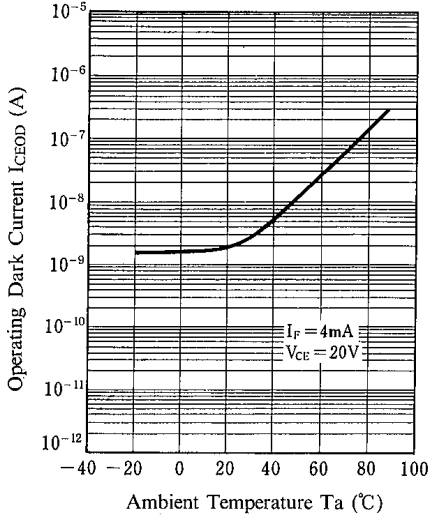

Output Characteristics (T_a=25°C)

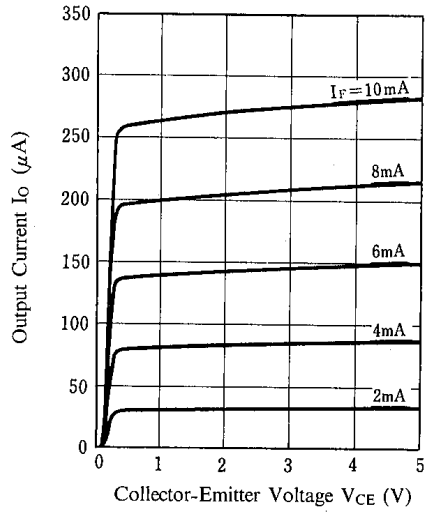

V_{CE} Saturation (T_a=25°C)

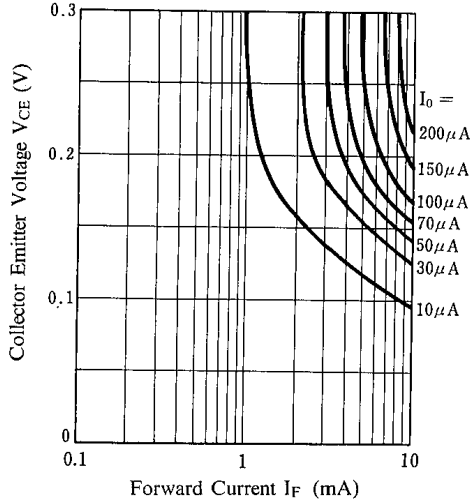

Spectral Response (T_a=25°C)

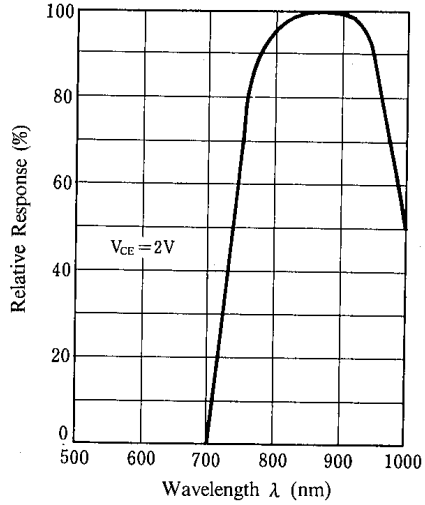

Output Current vs. Distance (T_a=25°C)

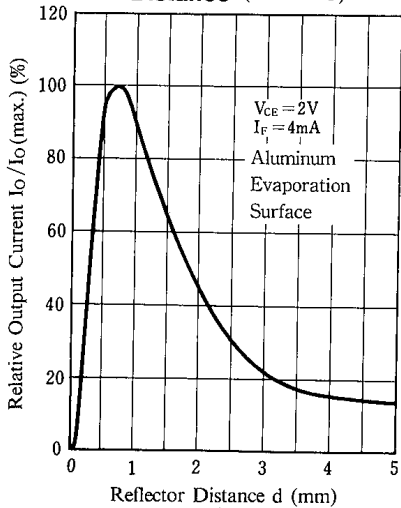

Output Current vs. Edge Distance (T_a=25°C)

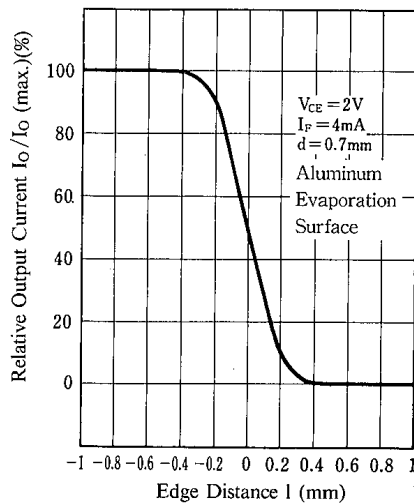

Measuring Specification for Edge Response

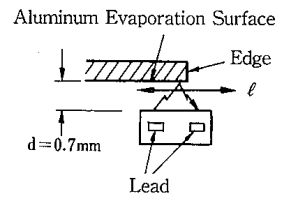

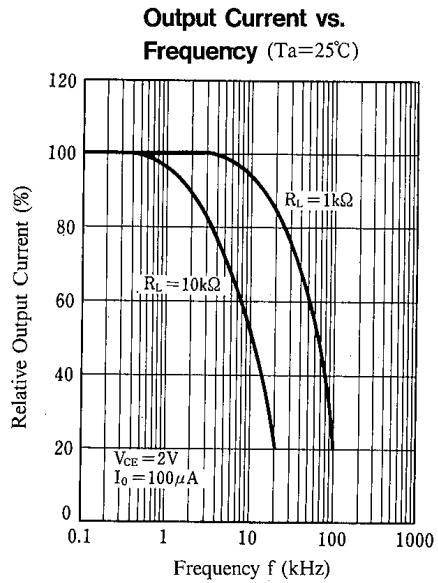
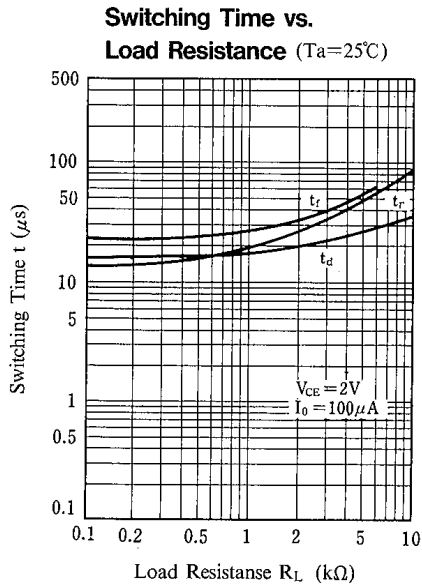

PRECAUTION FOR HANDLING

1. Soldering to actual circuit board

Soldering condition

- Lead's of soldering temperature and heating time.
260 °C maximum, less than 10 seconds, at least 1.5mm from body.
- Heated condition of plastic package.
Lower than 240 °C of maximum surface temperature, less than 30 seconds of time kept higher than 200 °C.

Soldering Method

1) Reflow Method

Recommended temperature profile of its method.

- ① Preparatory heating condition : 120 ~ 150 °C about 60 sec.
- ② Recommended soldering temperature : 230 ~ 240 °C about 3 ~ 5 sec.
- ③ Slowly cool down right after soldering.
- ④ Soldering to be done within twice under this condition.

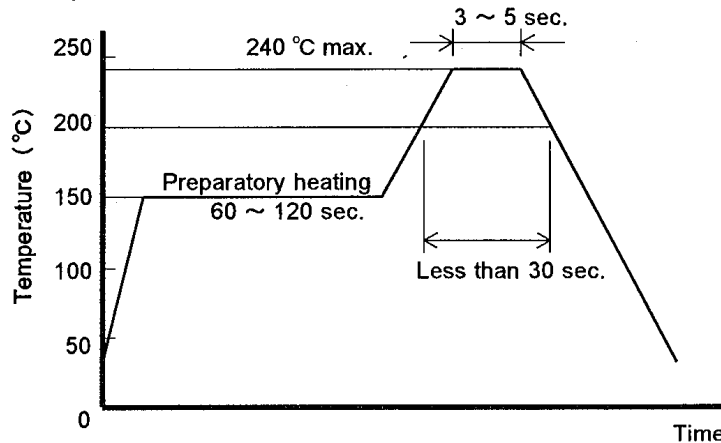

2) Reflow Method (In case of infrared heating)

- Temperature profile : Same to the above
- Avoid direct irradiation to the plastic package because it is black colored, absorbs the Infrared Radiation and its surface temperature will be higher than lead itself.

3) The other method

Avoid rapid heating up like dipping the devices directly into the melting solder or vapor phase method.

(VPS)

If the device is heated to high temperature and kept in its condition for longer time, it would affect to its reliability. It is necessary to solder in short time as soon as possible.

2. Cleaning

Avoid washing of the device after soldering by reflow method.

3. Attention in handling

- 1) Treat not to touch the lens surface.
- 2) Avoid dust and any other foreign materials (paint, bonding material, etc.) on the lens surface.
- 3) Never to apply reverse voltage (V_{EC}) of more than 6V on the photo transistor when measuring the characteristics or adjusting the system. If applied, it causes to lower the sensitivity.
- 4) When mounting, special care has to be taken on the mounting position and tilting of the device because it is very important to place the device to the optimum position to the object.

4. Storage

In order to prevent from degradation of this device in moisturing at reflow method, so that this device is contained in dampproof packaging. And the leads are silver plated and they are discolored if the device is left open to the air for long after taken out of the envelope. It causes deterioration of soldering characteristics. So that mount the device as short as possible after opening the envelope.

2

1. Taping Size

- 1) Carrier tape is used with Styrene type Carbonated Plastic.
- 2) Cover tape is used with electro statistically prevention treated Polyester type tape.
- 3) Product taping direction is to place the index mark against the pull out direction of the tape as in the drawing.

Pull out direction of tape →

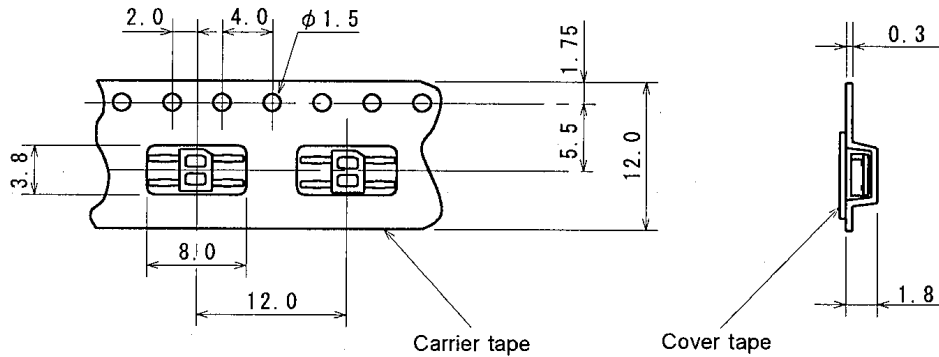

2

2. Taping Strength

Pullup the cover tape from the carrier tape, and when the opening angle comes around 10 ~ 15°, and the peeling-off strength is to be within the power of 20 ~ 70g.

3. Packaging

- 1) The taped products are to be rolled up on the taping reel as on the drawing.
- 2) Rolling up specification
 - ① Start Rolling : Carrier tape open space more than 20 Pieces.
 - ② End of Rolling : Carrier tape open space more than 20 Pieces, and 2 round of reel space at the cover tape only.
- 3) Taping quantity : 3,000 Pieces
- 4) Seal off after putting each reels in a vinyl bag with silica gel (3 bags).

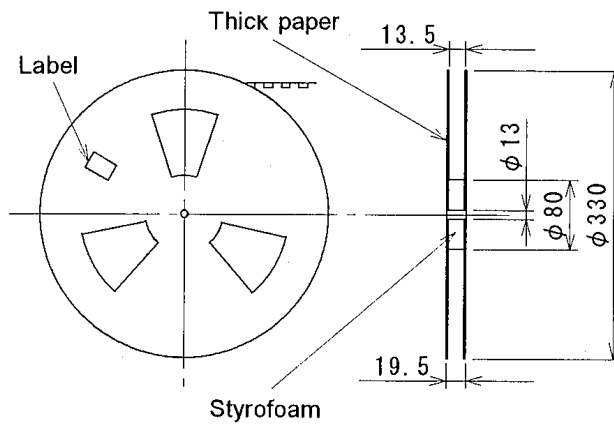

1. Taping Size

- 1) Carrier tape is used with Styrene type Carbonated Plastic.
- 2) Cover tape is used with electro statistically prevention treated Polyester type tape.
- 3) Product taping direction is to place the index mark against the pull out direction of the tape as in the drawing.

Pull out direction of tape →

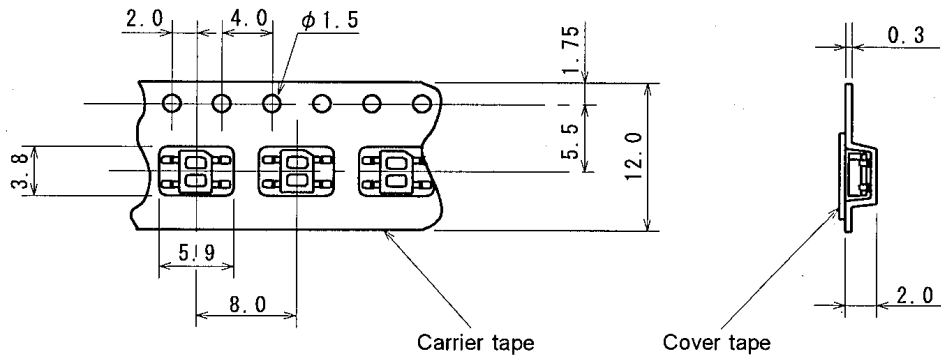

2

2. Taping Strength

Pullup the cover tape from the carrier tape, and when the opening angle comes around $10 \sim 15^\circ$, and the peeling-off strength is to be within the power of 20 ~ 70g.

3. Packaging

- 1) The taped products are to be rolled up on the taping reel as on the drawing.
- 2) Rolling up specification
 - ① Start Rolling : Carrier tape open space more than 20 Pieces.
 - ② End of Rolling : Carrier tape open space more than 20 Pieces, and 2 round of reel space at the cover tape only.
- 3) Taping quantity : 4,000 Pieces
- 4) Seal off after putting each reels in a vinyl bag with silica gel (3 bags).

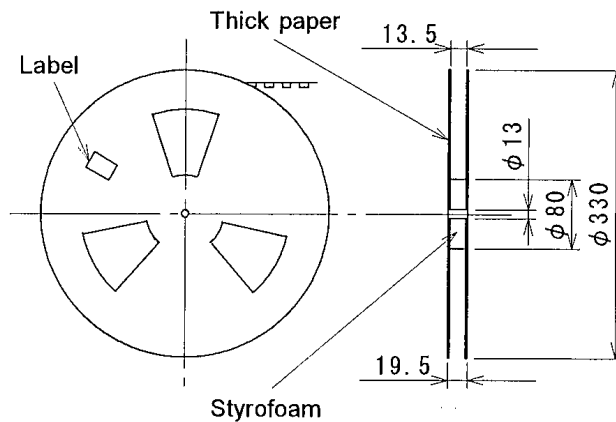

MEMO

[CAUTION]

The specifications on this databook are only given for information, without any guarantee as regards either mistakes or omissions. The application circuits in this databook are described only to show representative usages of the product and not intended for the guarantee or permission of any right including the industrial rights.