

4-Channel Constant Current White LED Driver

General Description

The LP3360 is a low-dropout bias supply for white LEDs is a high-performance alternative to the simple ballast resistors used in conventional white LED designs. It supports 4 white LEDs with regulated constant current for uniform intensity. The LP3360 maintains low dropout current regulators. The LP3360 requires a 45mV dropout at a 20mA load on each output to match the LED brightness. The brightness of LEDs can be tuned through a pulse width modulated signal at the PWM pin, the PWM frequency from 200Hz to 10KHz and the Duty from 0 to 100%.

The LP3360 is available in a SOT23-6 or MSOP-8 package.

Features

- ✧ 2.7V to 6V Input Voltage
- ✧ 20mA maxim sink current
- ✧ PWM tuned LED brightness through PWM pin
- ✧ Soft Start Function
- ✧ Built-in Thermal Protection
- ✧ $I_Q < 1\mu A$ in Shutdown
- ✧ SOT23-6 or MSOP-8 Package
- ✧ RoHS Compliant and 100% Lead (Pb)-Free

Typical Application Circuit

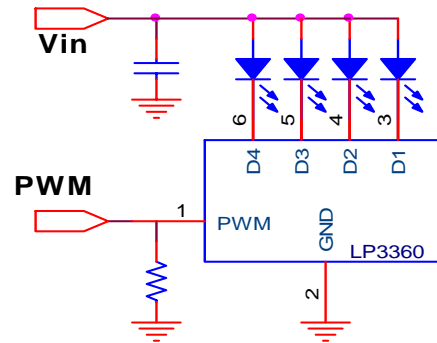

Order Information

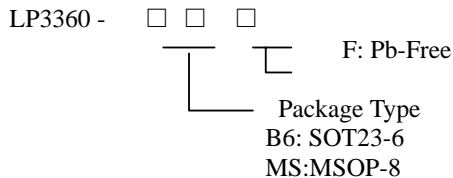

Marking Information

Please see website.

Applications

- ✧ LCD Panel
- ✧ Cellular and Smart mobile phone
- ✧ PDA/DSC
- ✧ PMP

Functional Pin Description

Package Type	Pin Configurations
	<p>(TOP VIEW)</p> <p>SOT23-6</p> <p>MSOP-8</p>

PIN		NAME	DESCRIPTION
SOT23-6	MSOP-8		
1	2	PWM/EN	Device enable (active high).
2	1,4	GND/PGND	Ground
3	5	LED4	LED 1 cathode terminal
4	6	LED3	LED2 cathode terminal
5	7	LED2	LED3 cathode terminal
6	8	LED1	LED3 cathode terminal
	3	VDD	Power Supply

Function Block Diagram

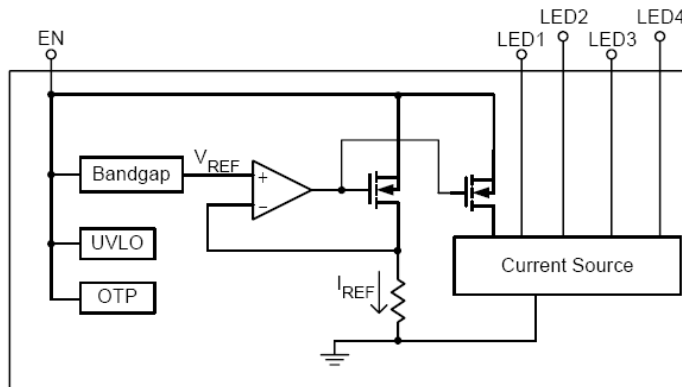

Absolute Maximum Ratings

- ✧ Input Voltage to GND (V_{INA}, V_{INB}) ----- 6V
- ✧ EN/ISET to GND Voltage ($V_{en/set}$) ----- 0.3V to $V_{in}+0.3V$
- ✧ Maximum DC Output Current(I_{out}) ----- 150mA
- ✧ Operating Junction Temperature Range (T_j) -----40°C to 150°C
- ✧ Maximum Soldering Temperature (at leads, 1 0sec) -----300°C

Thermal Information

- ✧ Maximum Power Dissipation (P_D) SOT23-6-----0.25W
- ✧ Maximum Power Dissipation (P_D) MSOP-8 ----- 1.25W
- ✧ Thermal Resistance (J_A) -----50°C/W

Electrical Characteristics

(Over recommended operating conditions unless specified otherwise) $V_{INA} = 3.6V, EN=High, T_A=25^\circ C$)

Symbol	Parameter	Conditions	LP3360			Unit
			Min.	Typ.	Max.	
V_{IN}	Input Voltage		3		5.5	V
V_{OUT}	Output Voltage Range		0.6		V_{INB}	V
I_Q	Quiescent Current	No Load, 1X mode		260	350	uA
I_{SHDN}	Shutdown Current	ENB = GND		0.1	1	μA
$I_{LED-ERR}$	LED Current Accuracy	3mA < I_{LED} < 30mA	19	20	21	mA
$I_{LED-LED-ERR}$	LED Channel Matching	Any two channel mismatch	-3		3	%
$V_{EN(L)}$	Enable Threshold Low				0.5	V
$V_{EN(H)}$	Enable Threshold High		2			V

Typical Operating Characteristics

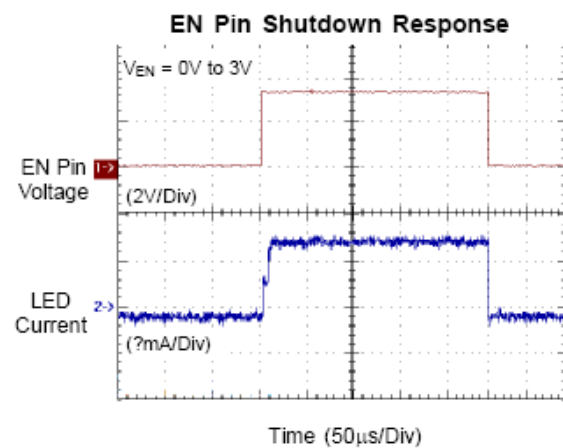
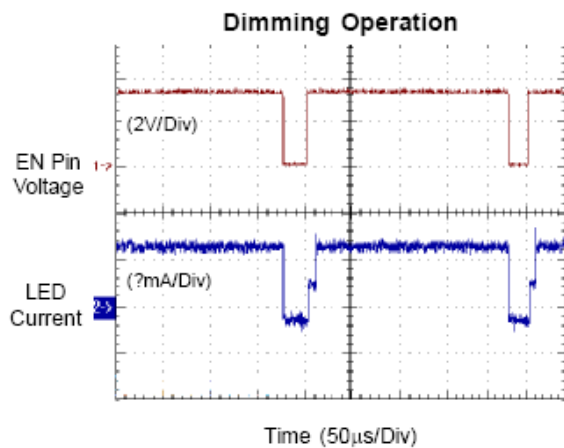
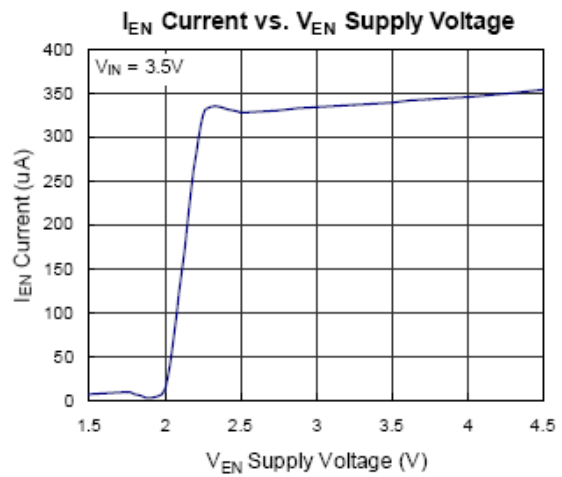
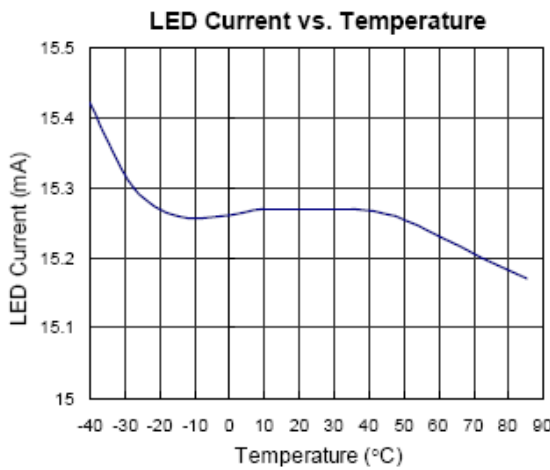
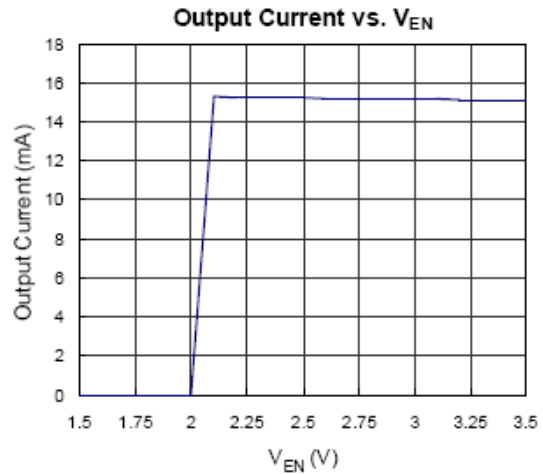
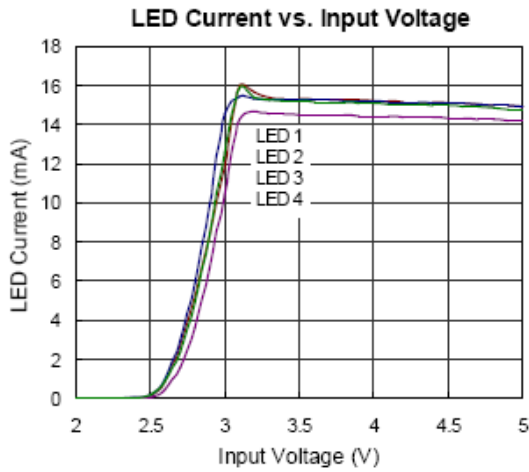

Packaging Information

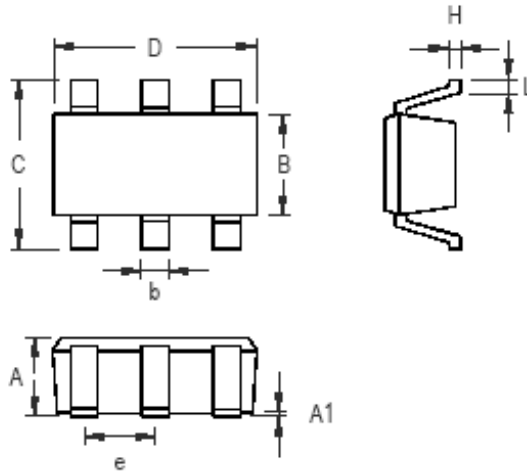

Symbol	Dimensions In Millimeters		Dimensions In Inches	
	Min	Max	Min	Max
A	0.889	1.295	0.031	0.051
A1	0.000	0.152	0.000	0.006
B	1.397	1.803	0.055	0.071
b	0.250	0.560	0.010	0.022
C	2.591	2.997	0.102	0.118
D	2.692	3.099	0.106	0.122
e	0.838	1.041	0.033	0.041
H	0.080	0.254	0.003	0.010
L	0.300	0.610	0.012	0.024

SOT- 26 Surface Mount Package

8-Pin Plastic MSOP(DN)

