



BU941ZP BU941ZPFI

HIGH VOLTAGE IGNITION COIL DRIVER NPN POWER DARLINGTON TRANSISTORS

- n VERY RUGGED BIPOLAR TECHNOLOGY
- n BUILT IN CLAMPING ZENER
- n HIGH OPERATING JUNCTION TEMPERATURE
- n FULLY INSULATED PACKAGE (U.L. COMPLIANT) FOR EASY MOUNTING

APPLICATION

- n HIGH RUGGEDNESS ELECTRONIC IGNITIONS

DESCRIPTION

The devices are bipolar Darlington transistors manufactured using Multi-Epitaxial Planar technology. They have been properly designed to be used in Automotive environment as electronic ignition power actuators.

Figure 1: Package

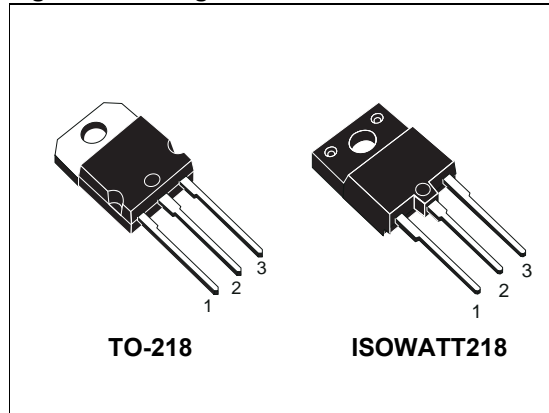

Figure 2: Internal Schematic Diagram

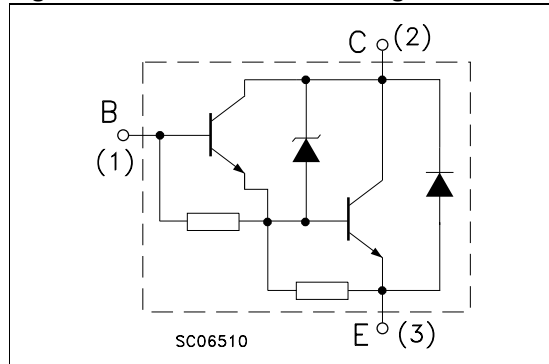

Table 1: Order Code

Part Number	Marking	Package	Packaging
BU941ZP	BU941ZP	TO-218	TUBE
BU941ZFI	BU941ZPFI	ISOWATT218	TUBE

BU941ZP BU941ZPFI

Table 2: Absolute Maximum Ratings

Symbol	Parameter	Value		Unit
		BU941ZP	BU941ZPFI	Unit
V_{CEO}	Collector-Emitter Voltage ($I_B = 0$)	350		V
V_{EBO}	Emitter-Base Voltage ($I_C = 0$)	5		V
I_C	Collector Current	15		A
I_{CM}	Collector Peak Current ($t_p < 5\text{ms}$)	30		A
I_B	Base Current	1		A
I_{BM}	Base Peak Current ($t_p < 5\text{ms}$)	5		A
P_{tot}	Total Dissipation at $T_C = 25\text{ }^\circ\text{C}$	155	65	W
V_{isol}	Insulation Withstand Voltage (RMS) from All Three Leads to External Heatsink	2500		V
T_{stg}	Storage Temperature	-65 to 175	-65 to 175	$^\circ\text{C}$
T_J	Max. Operating Junction Temperature	175	175	$^\circ\text{C}$

Table 3: Thermal Data

		TO-218	ISOWATT218	Unit
$R_{thj-case}$	Thermal Resistance Junction-Case Max	0.97	2.3	$^\circ\text{C/W}$

Table 4: Electrical Characteristics ($T_{case} = 25\text{ }^\circ\text{C}$ unless otherwise specified)

Symbol	Parameter	Test Conditions	Min.	Typ.	Max.	Unit
I_{CEO}	Collector Cut-off Current ($I_B = 0$)	$V_{CE} = 300\text{ V}$			100	μA
		$V_{CE} = 300\text{ V}$ $T_J = 125\text{ }^\circ\text{C}$			0.5	mA
I_{EBO}	Emitter Cut-off Current ($I_C = 0$)	$V_{EB} = 5\text{ V}$			20	mA
V_{CL}^*	Clamping Voltage	$I_C = 100\text{ mA}$	350		500	V
$V_{CE(sat)}^*$	Collector-Emitter Saturation Voltage	$I_C = 8\text{ A}$ $I_B = 100\text{ mA}$			1.8	V
		$I_C = 10\text{ A}$ $I_B = 250\text{ mA}$			1.8	V
		$I_C = 12\text{ A}$ $I_B = 300\text{ mA}$			2	V
$V_{BE(sat)}^*$	Base-Emitter Saturation Voltage	$I_C = 8\text{ A}$ $I_B = 100\text{ mA}$			2.2	V
		$I_C = 10\text{ A}$ $I_B = 250\text{ mA}$			2.5	V
		$I_C = 12\text{ A}$ $I_B = 300\text{ mA}$			2.7	V
h_{FE}^*	DC Current Gain	$I_C = 5\text{ A}$ $V_{CE} = 10\text{ V}$	300			
	Functional Test	$V_{CC} = 24\text{ V}$ $L = 7\text{ mH}$ (see fig. 12)	10			A
t_s t_f	INDUCTIVE LOAD Storage Time Fall Time	$V_{CC} = 12\text{ V}$ $L = 7\text{ mH}$ $V_{BE(off)} = 0\text{ V}$ $R_{BE} = 47\text{ }\Omega$		15		μs
		$V_{Clamp} = 300\text{ V}$ $I_C = 7\text{ A}$ $I_B = 70\text{ mA}$ (see fig. 14)		0.5		μs
V_F	Diode Forward Voltage	$I_F = 10\text{ V}$			2.5	V

* Pulsed: Pulsed duration = 300 μs , duty cycle $\leq 1.5\%$.

Figure 3: Safe Operating Area

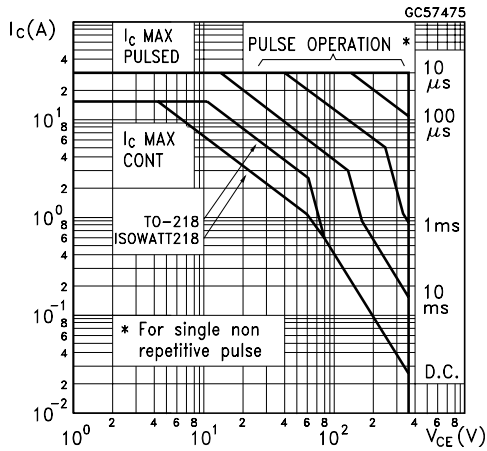

Figure 4: DC Current Gain

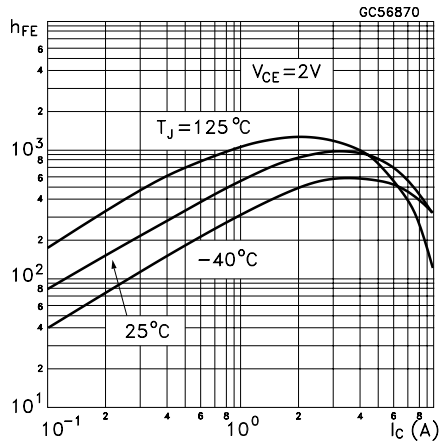

Figure 5: Collector-Emitter Saturation Voltage

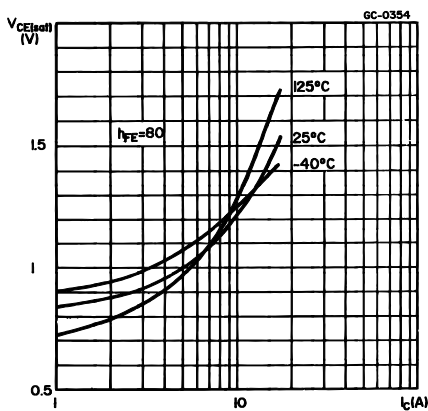

Figure 6: Derating Curves

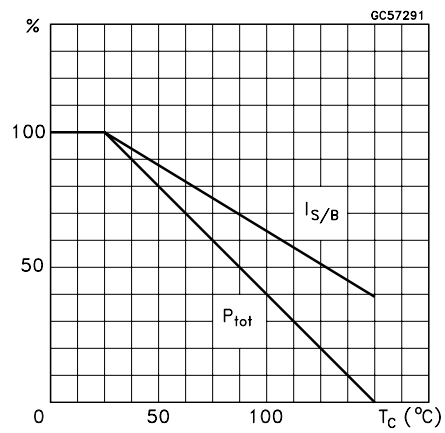

Figure 7: DC Current Gain

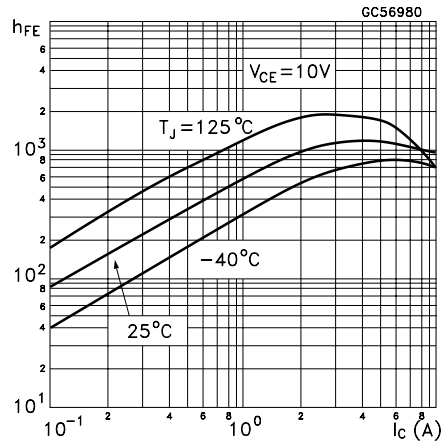

Figure 8: Collector-Emitter Saturation Voltage

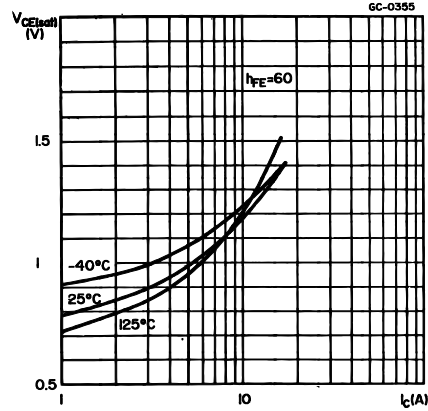

Figure 9: Base-Emitter Saturation Voltage

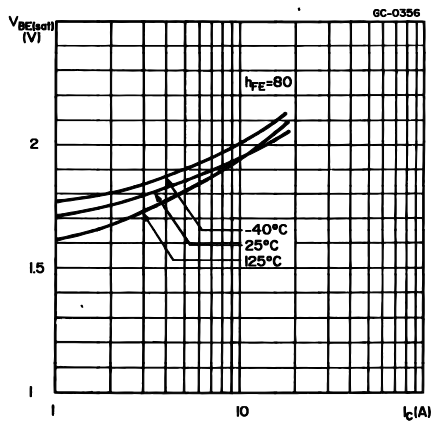

Figure 11: Base-Emitter Saturation Voltage

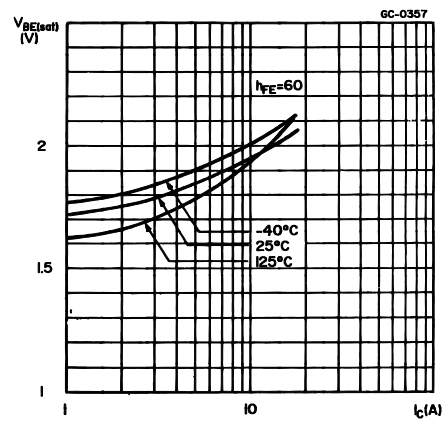

Figure 10: Collector-Emitter Saturation Voltage

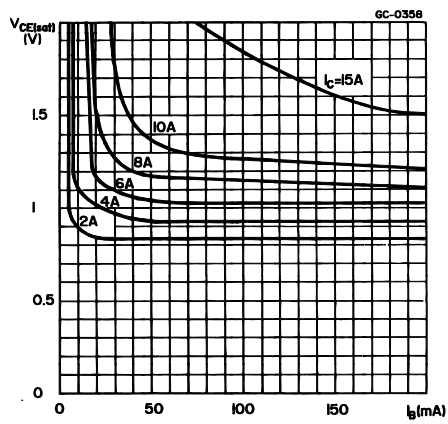

Figure 12: Functional Test Circuit

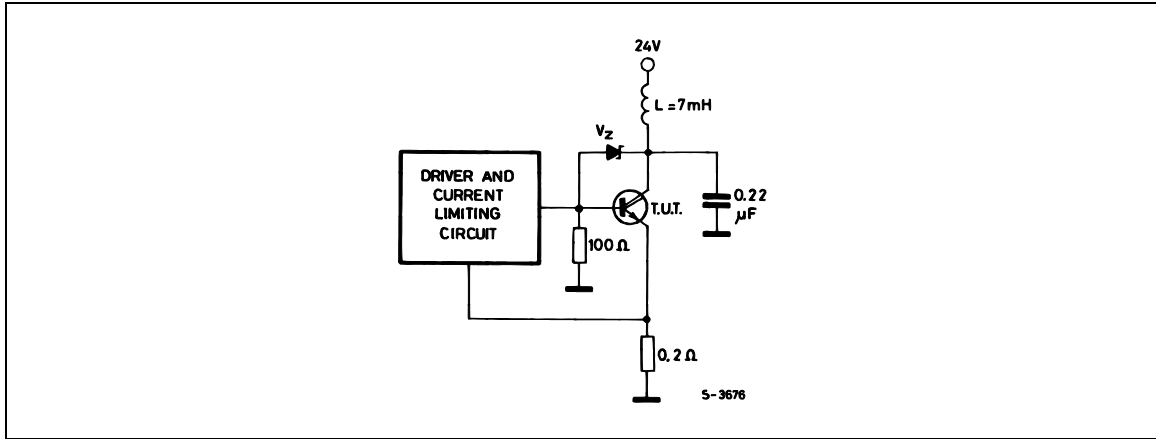

Figure 13: Functional Test Waveforms

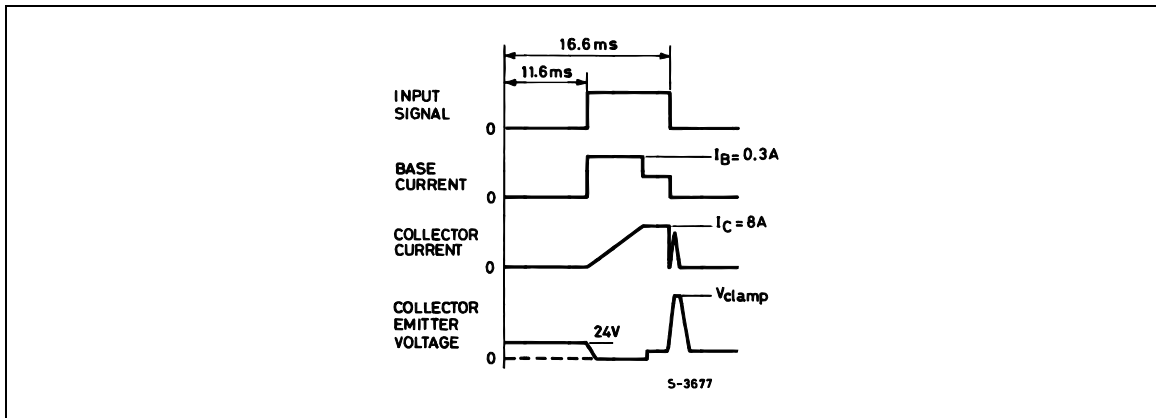
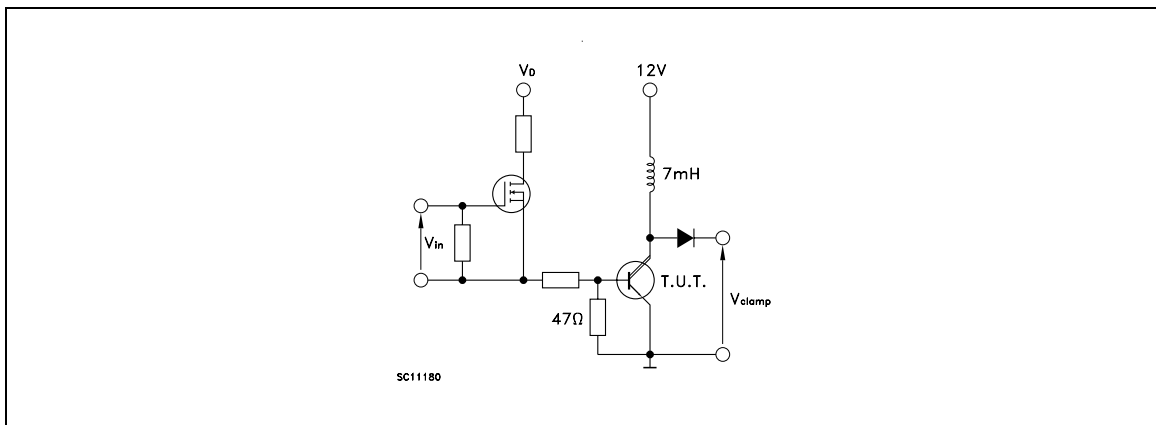
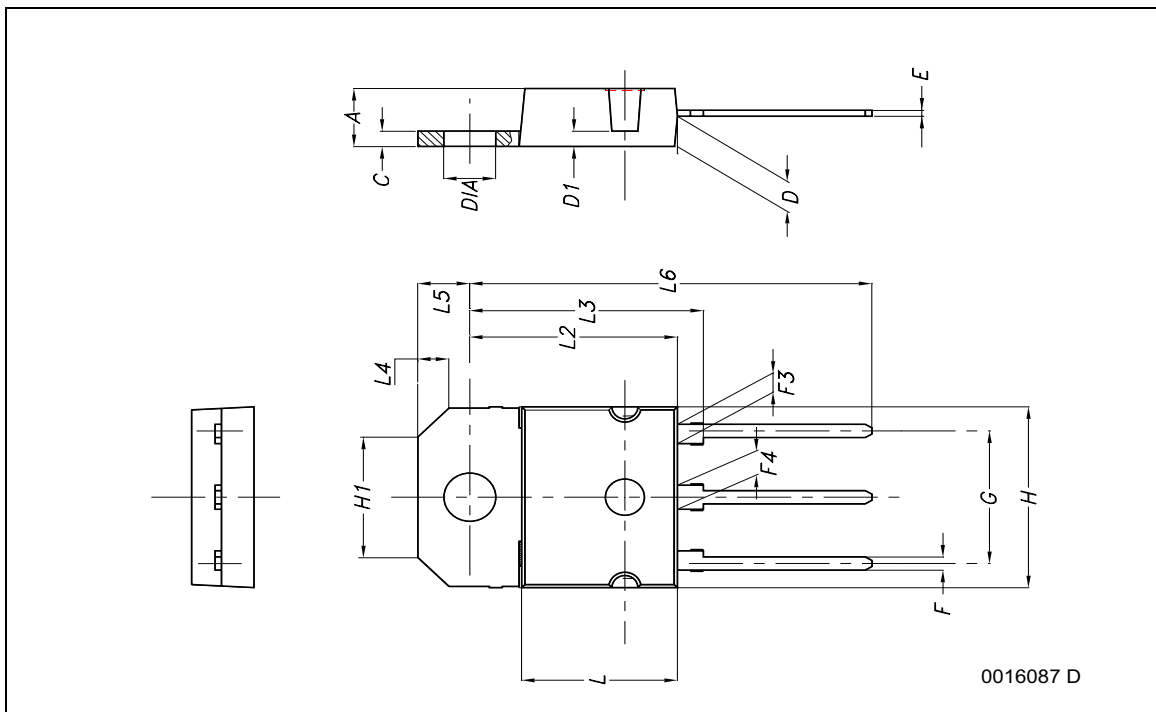

Figure 14: Switching Time Test Circuit



TO-218 (SOT-93) MECHANICAL DATA

DIM.	mm.		
	MIN.	TYP	MAX.
A	4.70		4.90
C	1.17		1.37
D		2.50	
D1		1.27	
E	0.50		0.78
F	1.10		1.30
F3		1.75	
F4		2.10	
G	10.80		11.10
H	14.70		15.20
H1		10.00	
L			12.20
L2			16.20
L3		18.00	
L4		2.40	
L5	3.95		4.15
L6		31.00	
Dia	4.00		4.10



ISOWATT218 (option "B") MECHANICAL DATA

DIM.	mm.		
	MIN.	TYP	MAX.
A	5.35		5.65
B		2.5	
C	3.30		3.80
D	2.90		3.10
D1	1.88		2.08
E	0.75		0.95
F	0.75		0.95
F2	1.50		1.85
F3	1.90		2.20
F5			1.10
G	10.80		11.20
H	15.80		16.20
L		9	
L1	20.80		21.20
L2	19.10		19.90
L3	22.80		23.60
L4	40.50		42.50
L5	4.85		5.25
L6	20.25		20.75
N	2.0		2.40
R		4.6	
Dia	3.50		3.70

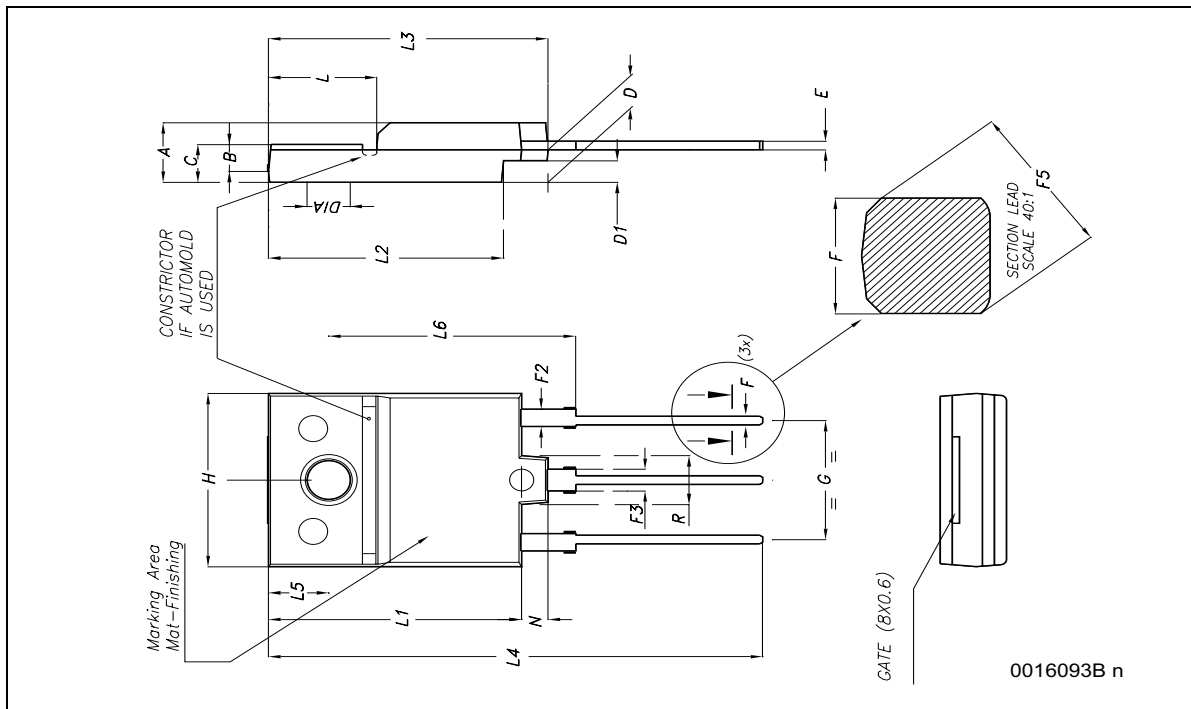

Table 5: Revision History

Date	Release	Change Designator
22-Apr-2002	4	Fourth Release
09-Sep-2004	5	Fifth Release
03-Feb-2005	6	Mechanical Data has been updated

Information furnished is believed to be accurate and reliable. However, STMicroelectronics assumes no responsibility for the consequences of use of such information nor for any infringement of patents or other rights of third parties which may result from its use. No license is granted by implication or otherwise under any patent or patent rights of STMicroelectronics. Specifications mentioned in this publication are subject to change without notice. This publication supersedes and replaces all information previously supplied. STMicroelectronics products are not authorized for use as critical components in life support devices or systems without express written approval of STMicroelectronics.

The ST logo is a registered trademark of STMicroelectronics
All other names are the property of their respective owners

© 2005 STMicroelectronics - All Rights Reserved

STMicroelectronics group of companies

Australia - Belgium - Brazil - Canada - China - Czech Republic - Finland - France - Germany - Hong Kong - India - Israel - Italy - Japan -
Malaysia - Malta - Morocco - Singapore - Spain - Sweden - Switzerland - United Kingdom - United States of America
www.st.com

