

General-purpose CMOS Logic IC Series (BU4S,BU4000B Series)



# High Voltage CMOS Logic ICs

## <Analog Switch>

**BU4066BC, BU4066BCF, BU4066BCFV, BU4051BC,  
BU4051BCF, BU4051BCFV, BU4052BC, BU4052BCF, BU4052BCFV,  
BU4053BC, BU4053BCF, BU4053BCFV, BU4551B, BU4551BF, BU4551BFV**

No.09050EAT05

### ●Description

BU4066BC series ICs each contain 4 independent switches capable of controlling either digital or analog signals. BU4051BC / BU4052BC / BU4053BC / and BU4551B series ICs are analog selectable composite multiplexer/demultiplexer. BU4051BC series is configured with 8 channels, BU4052BC is configured with two 4 channels, BU4053BC series is configured with three 2 channels, BU4551B series is configured with four 2 channels, and switches applicable for each channel are turned on according to digital signals of control terminal. Even if the logic amplitude (VDD-VSS) of the control signal is small, signals of large amplitude (VDD-VEE) can be switched.

### ●Features

- 1) Low power consumption
- 2) Wide operating supply voltage (3[V]~18[V])
- 3) High input impedance
- 4) L-TTL2 input and LS-TTL1 can be driven directly.
- 5) Applicable channel switches can be turned "ON" and "OFF" by the digital control signal.
- 6) Small control voltage (VDD-VSS) can control signals of large amplitude (VDD-VEE).
- 7) Linearity with excellent transfer characteristics

### ●Use

This product is used as the switch and chopper modulation circuit of analog and digital signals. Since ON resistance of each switch is low, the product can be connected to low impedance circuit. The product can be used as ON/OFF switch and changeover switch of high-speed lines without degrading analog signals such as voice and images.

### ●Lineup

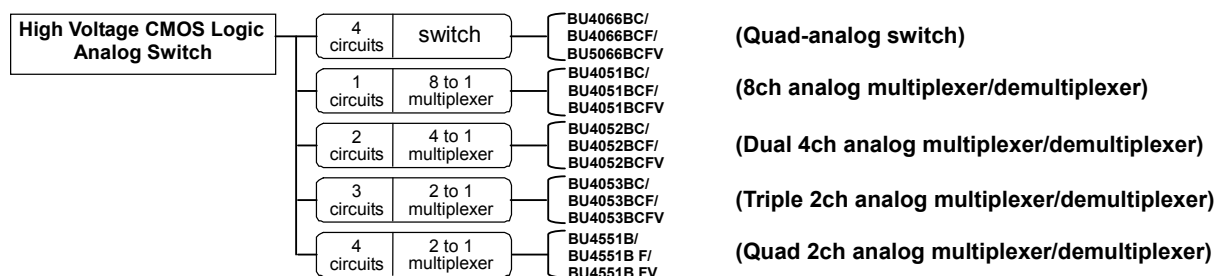

● Absolute Maximum Ratings

Parameter	Symbol	Limit				Unit
		BU4066BC	BU4051BC	BU4052BC	BU4053BC	
Power Supply Voltage	VDD	-0.5 to 20			-0.3 to 18	V
Supply current	Iin	± 10				mA
Operating temperature	Topr	-40 to 85				°C
Storage temperature	Tstg	-55 to 150				°C
Input Voltage	VIN	-0.5 to VDD+0.5			-0.3 to VDD+0.3	V
Maximum junction temperature	Tjmax	150				°C

● Recommended Operating Conditions

Parameter	Symbol	Limit				Unit
		BU4066BC	BU4051BC	BU4052BC	BU4053BC	
Operating Power Supply	VDD	3 to 18			3 to 16	V
Input Voltage	VIN	0 to VDD				V

● Thermal Derating Curve

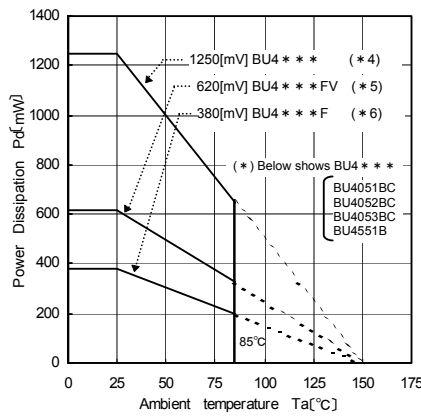
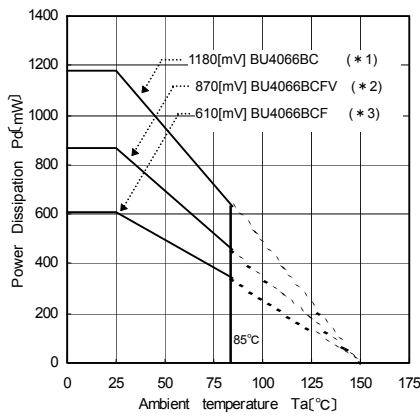

(*1)	9.5	mW/°C
(*2)	7.0	
(*3)	4.9	
(*4)	10.0	
(*5)	5.0	
(*6)	3.1	

When used at Ta=25[°C] or above, values of above are reduced per 1[°C]. Allowable loss is the value for mounting 70[mm] x 70[mm] x 1.6[mm] FR4 glass epoxy circuit board copper foil area is 3% or less).

● I/O Interface

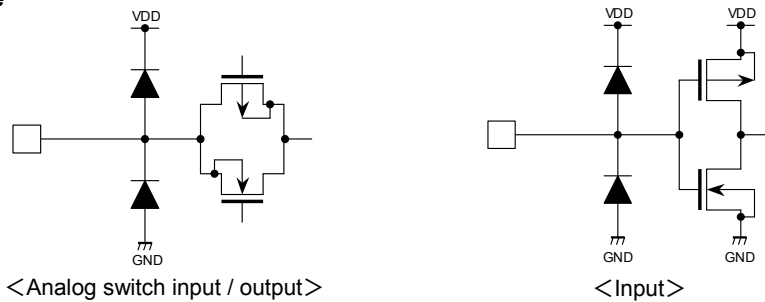

● Description of output rising / falling wave

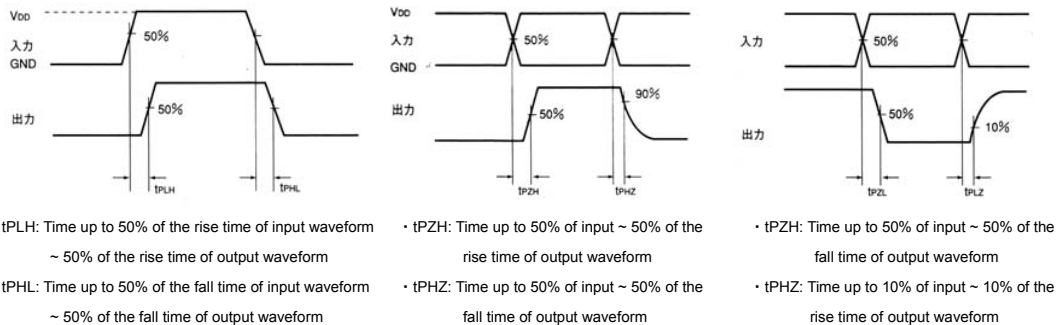

●Electrical Characteristics(BU4066BC)

DC Characteristics(Unless otherwise noted, VSS=0[V], Ta=25[°C])

Parameter	Symbol	Standard Value			Unit	VDD[V]	Condition	Fig.No
		MIN	TYP	MAX				
Input "H" voltage	VIH	3.5	-	-	V	5	-	-
		7.0	-	-		10		
		11.0	-	-		15		
Input "L" voltage	VIL	-	-	1.5	V	5	-	-
		-	-	3.0		10		
		-	-	3.75		15		
Input "H" current	IIH	-	-	0.3	μA	15	VIH=15[V]	-
Input "L" current	IIL	-	-	-0.3	μA	15	VIL=0[V]	-
ON resistance	RON	-	150	600	Ω	5	VIN=0.25[V] RL=10[kΩ]	1
		-	500	950		5	VIN=2.5[V] RL=10[kΩ]	
		-	200	600		5	VIN=5[V] RL=10[kΩ]	
		-	120	500		10	VIN=5[V] RL=10[kΩ]	
		-	80	280		15	VIN=7.5[V] RL=10[kΩ]	
ON resistance defluxion	ΔRON	-	25	-	Ω	5	VI=VDD/2 RL=10[kΩ]	-
		-	10	-		10		
		-	5	-		15		
Channel-OFF Leakage current	IOFF	-	-	0.3	μA	15	VIN=15[V] VOUT=0[V]	-
		-	-	-0.3		15	VIN=0[V] VOUT=15[V]	
Static supply current	IDD	-	-	1.0	μA	5	VI=VDD or GND	-
		-	-	2.0		10		
		-	-	4.0		15		
Input capacitance (control input)	CC	-	8	-	pF	-	f=1[MHz]	-
Input capacitance (switch input)	CS	-	10	-	pF	-	f=1[MHz]	-

Switching Characteristics(Unless otherwise noted, VSS=0[V], Ta=25[°C], CL=50[pF])

Parameter	Symbol	Standard Value			Unit	VDD[V]	Condition	Fig.No
		MIN	TYP	MAX				
Propagation delay time SWIN→OUT	tPLH tPHL	-	20	50	ns	5	RL=10[kΩ]	2 · 3
		-	12	40		10		
		-	10	30		15		
Propagation delay time CONT→OUT	tPHZ, tPLZ tPZH, tPZL	-	40	90	ns	5	Output "H" "L" → "Hi Z" RL=1[kΩ]	4 · 5 6 · 7
		-	35	80		10		
		-	30	70		15		
Propagation delay time CONT→OUT	tPHZ, tPLZ tPZH, tPZL	-	60	140	ns	5	Output "Hi Z" → "H" "L" RL=1[kΩ]	4 · 5 6 · 7
		-	20	50		10		
		-	15	40		15		
Feed through attenuation	FT	-	0.7	-	MHz	5	VSS=-5[V] RL=10[kΩ]	-
Sine wave distortion	D	-	0.1	-	%	5	VSS=-5[V] RL=10[kΩ]	-
Cross talk (CONT→OUT)	CTc	-	-	600	mVp-p	5	VSS=-5[V] RL=10[kΩ], f=1[MHz]	-
Cross talk(2) Between channels	CT	-	1	-	MHz	5	VSS=-5[V] RL=10[kΩ]	-

●Electrical Characteristics(BU4051BC)

DC Characteristics(Unless otherwise noted, VSS=0[V],Ta=25[°C])

Parameter	Symbol	Standard Value			Unit	VDD[V]	Condition	Fig.No
		MIN	TYP	MAX				
Input "H" voltage	VIH	3.5	-	-	V	5	-	-
		7.0	-	-		10		
		11.0	-	-		15		
Input "L" voltage	VIL	-	-	1.5	V	5	-	-
		-	-	3.0		10		
		-	-	4.0		15		
Input "H" current	IIH	-	-	0.3	μA	15	VIH=15[V]	-
Input "L" current	IIL	-	-	-0.3	μA	15	VIL=0[V]	-
ON resistance	RON	-	-	950	Ω	5	-	8
		-	-	250		10		
		-	-	160		15		
ON resistance defluxion	ΔRON	-	10	-	Ω	5	-	-
		-	6	-		10		
		-	4	-		15		
Channel-OFF Leakage current	IOFF	-	-	0.3	μA	15	-	-
		-	-	-0.3		15		
Static supply current	IDD	-	-	5	μA	5	VI=VDD or GND	-
		-	-	10		10		
		-	-	15		15		

Switching Characteristics(Unless otherwise noted, VSS=0[V],Ta=25[°C],CL=50[pF])

Parameter	Symbol	Standard Value			Unit	VDD[V]	Condition	Fig.No
		MIN	TYP	MAX				
Propagation delay time CHANNEL IN→OUT	tPLH tPHL	-	15	45	ns	5	-	9 · 10
		-	8	20		10		
		-	6	15		15		
Propagation delay time CONT→OUT	tPHZ,tPLZ tPZH,tPZL	-	170	550	ns	5	-	11 · 12 13 · 14 15 · 16 17 · 18
		-	90	240		10		
		-	70	160		15		
Propagation delay time INHIBIT→OUT	tPHZ,tPLZ tPZH,tPZL	-	150	450	ns	5	-	11 · 12 13 · 14 15 · 16 17 · 18
		-	70	210		10		
		-	50	160		15		
Maximum propagation frequency	fMAX.	-	20	-	MHz	5	VEE=-5[V]	-
Feed through attenuation	FT	-	0.5	-	MHz	5	VEE=-5[V]	-
Sine wave distortion	D	-	0.02	-	%	5	VEE=-5[V]	-
Input capacitance (control input)	CC	-	5	-	pF	-	-	-
Input capacitance (switch input)	CS	-	10	-	pF	-	-	-

●Electrical Characteristics(BU4052BC)

DC Characteristics(Unless otherwise noted, VSS=0[V],Ta=25[°C])

Parameter	Symbol	Standard Value			Unit	VDD[V]	Condition	Fig.No
		MIN	TYP	MAX				
Input "H" voltage	VIH	3.5	-	-	V	5	-	-
		7.0	-	-		10		
		11.0	-	-		15		
Input "L" voltage	VIL	-	-	1.5	V	5	-	-
		-	-	3.0		10		
		-	-	4.0		15		
Input "H" current	I <sub>IH</sub>	-	-	0.3	μA	15	VIH=15[V]	-
Input "L" current	I <sub>IL</sub>	-	-	-0.3	μA	15	VIL=0[V]	-
ON resistance	RON	-	-	950	Ω	5	-	19
		-	-	250		10		
		-	-	160		15		
ON resistance defluxion	ΔRON	-	10	-	Ω	5	-	-
		-	6	-		10		
		-	4	-		15		
Channel-OFF Leakage current	IOFF	-	-	0.3	μA	15	-	-
		-	-	-0.3		15		
Static supply current	IDD	-	-	5	μA	5	VI=VDD or GND	-
		-	-	10		10		
		-	-	15		15		

Switching Characteristics(Unless otherwise noted, Ta=25°C,CL=50pF)

Parameter	Symbol	Standard Value			Unit	VDD[V]	Condition	Fig.No
		MIN	TYP	MAX				
Propagation delay time SWITCH IN→OUT	t <sub>PLH</sub> t <sub>PHL</sub>	-	15	45	ns	5	-	20 · 21
		-	8	20		10		
		-	6	15		15		
Propagation delay time CONT→OUT	t <sub>PHZ</sub> ,t <sub>PLZ</sub> t <sub>PZH</sub> ,t <sub>PZL</sub>	-	170	550	ns	5	-	22 · 23 24 · 25 26 · 27 28 · 29
		-	90	240		10		
		-	70	160		15		
Propagation delay time INH→OUT	t <sub>PHZ</sub> ,t <sub>PLZ</sub> t <sub>PZH</sub> ,t <sub>PZL</sub>	-	150	450	ns	5	-	22 · 23 24 · 25 26 · 27 28 · 29
		-	70	210		10		
		-	50	160		15		
Maximum propagation frequency	f <sub>MAX.</sub>	-	20	-	MHz	5	VEE=-5[V]	-
Feed through attenuation	FT	-	0.5	-	MHz	5	VEE=-5[V]	-
Sine wave distortion	D	-	0.02	-	%	5	VEE=-5[V]	-
Input capacitance (control input)	CC	-	5	-	pF	-	-	-
Input capacitance (switch input)	CS	-	10	-	pF	-	-	-

●Electrical Characteristics(BU4053BC)

DC Characteristics(Unless otherwise noted, VSS=0[V],Ta=25[°C])

Parameter	Symbol	Standard Value			Unit	VDD[V]	Condition	Fig.No
		MIN	TYP	MAX				
Input "H" voltage	VIH	3.5	-	-	V	5	-	-
		7.0	-	-		10		
		11.0	-	-		15		
Input "L" voltage	VIL	-	-	1.5	V	5	-	-
		-	-	3.0		10		
		-	-	4.0		15		
Input "H" current	I <sub>IH</sub>	-	-	0.3	μA	15	VIH=15[V]	-
Input "L" current	I <sub>IL</sub>	-	-	-0.3	μA	15	VIL=0[V]	-
RON resistance	RON	-	-	950	Ω	5	-	30
		-	-	250		10		
		-	-	160		15		
RON resistance defluxion	ΔRON	-	10	-	Ω	5	-	-
		-	6	-		10		
		-	4	-		15		
Channel-OFF Leakage current	IOFF	-	-	0.3	μA	15	-	-
		-	-	-0.3		15		
Static supply current	IDD	-	-	5	μA	5	VI=VDD or GND	-
		-	-	10		10		
		-	-	15		15		

Switching Characteristics(Unless otherwise noted, VSS=0[V],Ta=25[°C],CL=50[pF])

Parameter	Symbol	Standard Value			Unit	VDD[V]	Condition	Fig.No
		MIN	TYP	MAX				
Propagation delay time SW IN→OUT	t <sub>PLH</sub> t <sub>PHL</sub>	-	15	45	ns	5	-	31 · 32
		-	8	20		10		
		-	6	15		15		
Propagation delay time CONT→OUT	t <sub>PHZ</sub> ,t <sub>PLZ</sub> t <sub>PZH</sub> ,t <sub>PZL</sub>	-	170	550	ns	5	-	33 · 34 35 · 36
		-	90	240		10		
		-	70	160		15		
Propagation delay time INH→OUT	t <sub>PHZ</sub> ,t <sub>PLZ</sub> t <sub>PZH</sub> ,t <sub>PZL</sub>	-	150	380	ns	5	-	37 · 38 39 · 40
		-	70	200		10		
		-	50	160		15		
Maximum propagation frequency	f <sub>MAX.</sub>	-	20	-	MHz	5	VEE=-5[V]	-
Feed through attenuation	FT	-	0.7	-	MHz	5	VEE=-5[V]	-
Sine wave distortion	D	-	0.02	-	%	5	VEE=-5[V]	-
Input capacitance (control input)	CC	-	5	-	pF	-	-	-
Input capacitance (switch input)	CS	-	10	-	pF	-	-	-

●Electrical Characteristics(BU4551BC)

DC Characteristics(Unless otherwise noted, VSS=0[V], Ta=25[°C])

Parameter	Symbol	Standard Value			Unit	VDD[V]	Condition	Fig.No
		MIN	TYP	MAX				
Input "H" voltage	VIH	3.5	-	-	V	5	-	-
		7.0	-	-		10		
		11.0	-	-		15		
Input "L" voltage	VIL	-	-	1.5	V	5	-	-
		-	-	3.0		10		
		-	-	4.0		15		
Input "H" current	I <sub>IH</sub>	-	-	0.3	μA	15	VIH=15[V]	-
Input "L" current	I <sub>IL</sub>	-	-	-0.3	μA	15	VIL=0[V]	-
ON resistance	RON	-	-	1100	Ω	5	-	41
		-	-	500		10		
		-	-	280		15		
ON resistance defluxion	ΔRON	-	25	-	Ω	5	-	-
		-	10	-		10		
		-	5	-		15		
Channel-OFF Leakage current	IOFF	-	-	0.3	μA	15	-	-
		-	-	-0.3		15		
Static supply current	IDD	-	-	5	μA	5	VI=VDD or GND	-
		-	-	10		10		
		-	-	15		15		

Switching Characteristics(Unless otherwise noted, VSS=0[V], Ta=25[°C], CL=50[pF])

Parameter	Symbol	Standard Value			Unit	VDD[V]	Condition	Fig.No
		MIN	TYP	MAX				
Propagation delay time SW IN→OUT	t <sub>PLH</sub> t <sub>PHL</sub>	-	35	-	ns	5	-	42 · 43
		-	15	-		10		
		-	12	-		15		
Propagation delay time CONT→OUT	t <sub>PZH</sub> t <sub>PHZ</sub>	-	360	-	ns	5	-	44 · 45
		-	160	-		10		
		-	120	-		15		
Propagation delay time INH→OUT	t <sub>PZL</sub> t <sub>PLZ</sub>	-	360	-	ns	5	-	46 · 47
		-	160	-		10		
		-	120	-		15		
Maximum propagation frequency	f <sub>MAX</sub>	-	15	-	MHz	-	VEE=-5[V]	-
Feed through attenuation	FT	-	0.7	-	MHz	-	VEE=-5[V]	-
Sine wave distortion	D	-	0.02	-	%	-	VEE=-5[V]	-
Input capacitance (control input)	CC	-	5	-	pF	-	-	-
Input capacitance (switch input)	CS	-	10	-	pF	-	-	-

● Reference Data (BU4066BC)

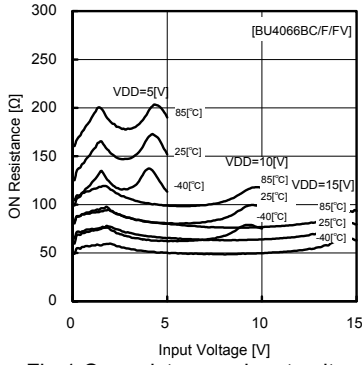

Fig.1 On resistance—input voltage

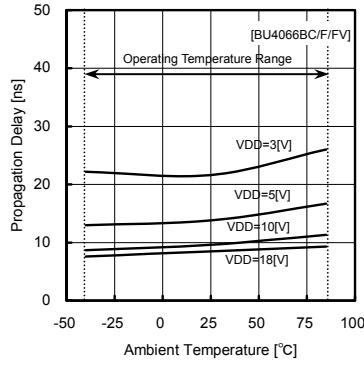

Fig.2 rising propagation delay (IN—OUT)

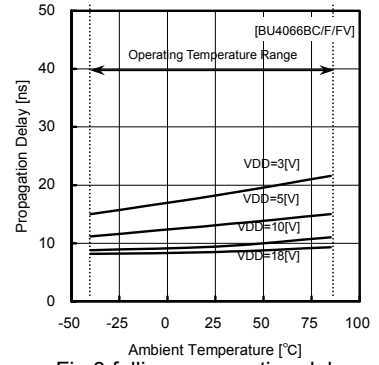

Fig.3 falling propagation delay (IN—OUT)

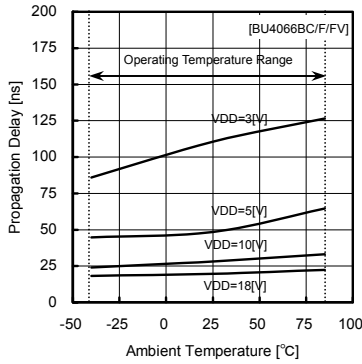

Fig.4 rising propagation delay (CONT—OUT, tPZH)

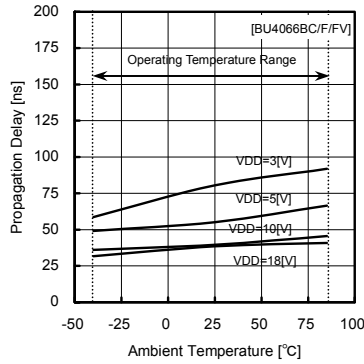

Fig.5 falling propagation delay (CONT—OUT, tPHZ)

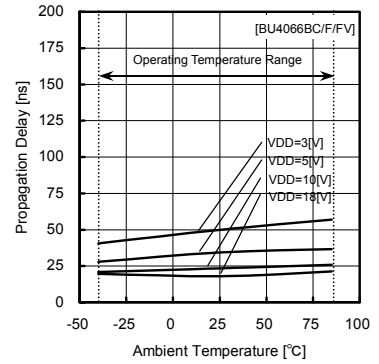

Fig.6 rising propagation delay (CONT—OUT, tPLZ)

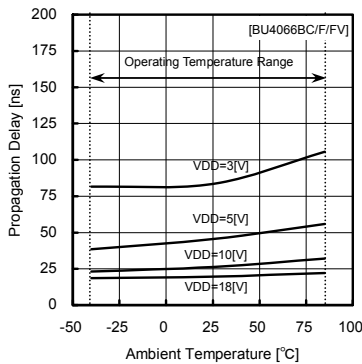

Fig.7 falling propagation delay (CONT—OUT, tPZL)



●Reference Data(BU4051BC)

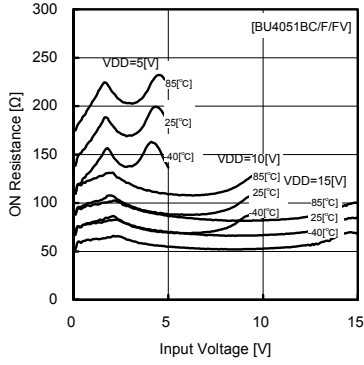

Fig.8 ON resistance—input voltage

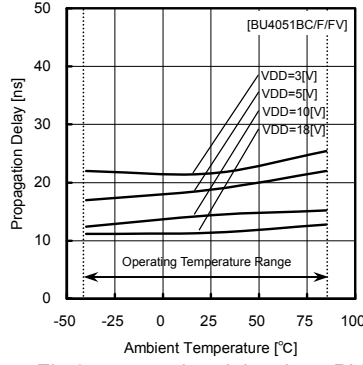

Fig.9 propagation delay time tPL (IN—OUT)

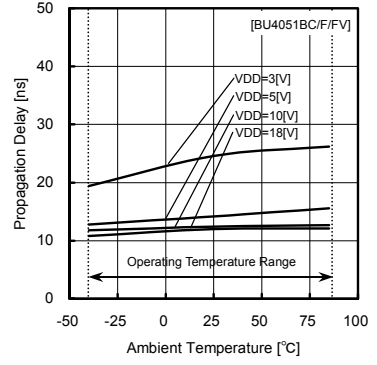

Fig.10 propagation delay time tPH (IN—OUT)

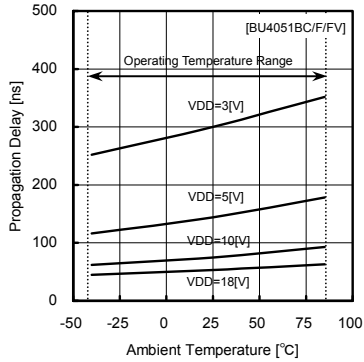

Fig.11 propagation delay time tPZH (CONT—OUT)

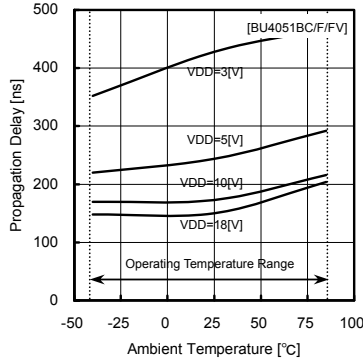

Fig.12 propagation delay time tPHZ (CONT—OUT)

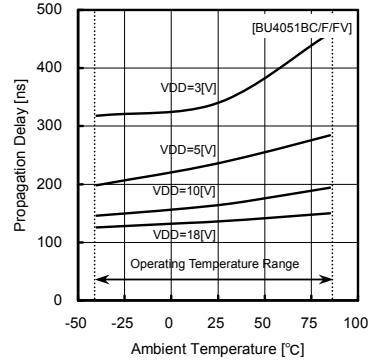

Fig.13 propagation delay time tPL (CONT—OUT)

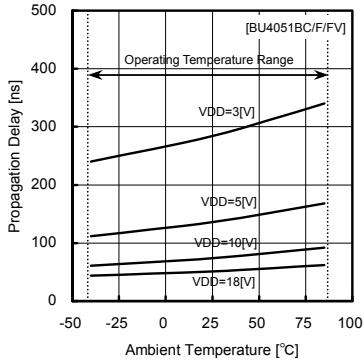

Fig.14 propagation delay time tPZL (CONT—OUT)

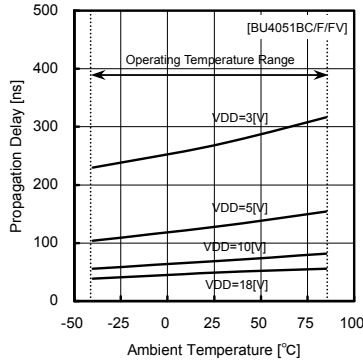

Fig.15 propagation delay time tPZH (INH—OUT)

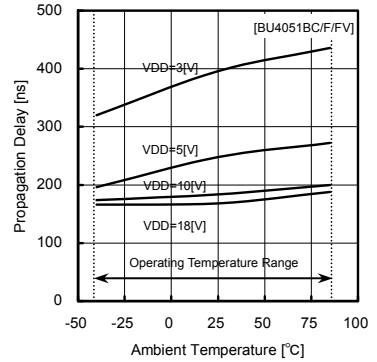

Fig.16 propagation delay time tPHZ (INH—OUT)

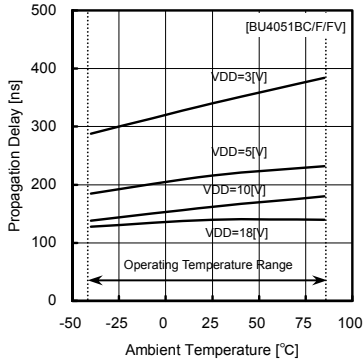

Fig.17 propagation delay time tPZL (INH—OUT)

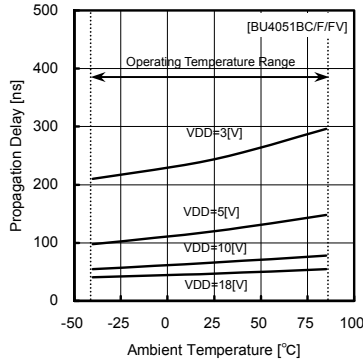

Fig.18 propagation delay time tPLZ (INH—OUT)

●Reference Data(BU4052BC)

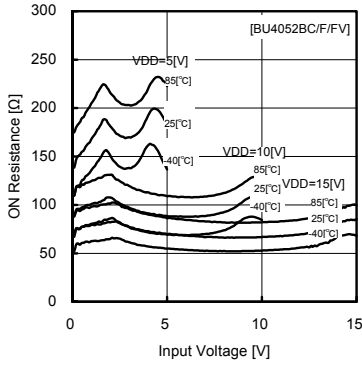

Fig.19 ON resistance—input voltage

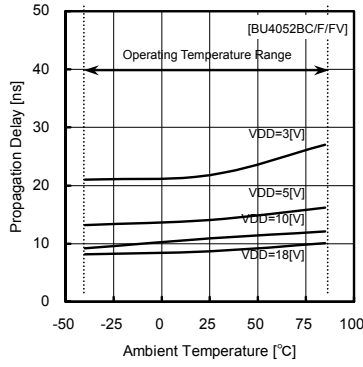

Fig.20 propagation delay time tPLH (IN—OUT)

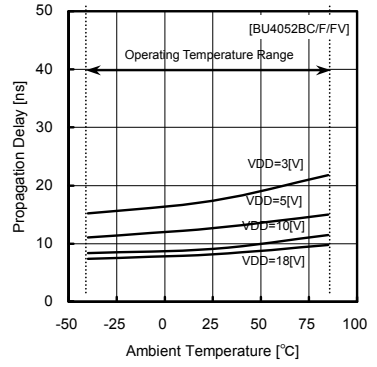

Fig.21 propagation delay time tPHL (IN—OUT)

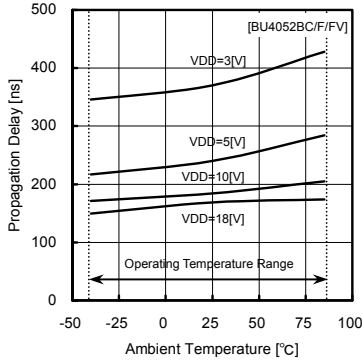

Fig.22 propagation delay time tPZH (CONT—OUT)

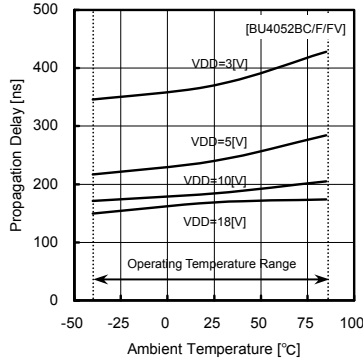

Fig.23 propagation delay time tPHZ (CONT—OUT)

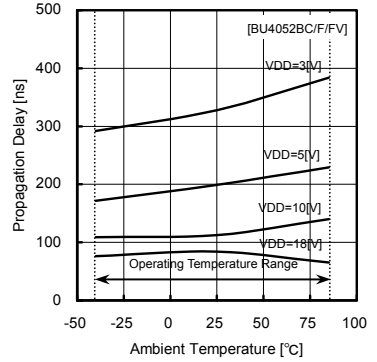

Fig.24 propagation delay time tPLZ (CONT—OUT)

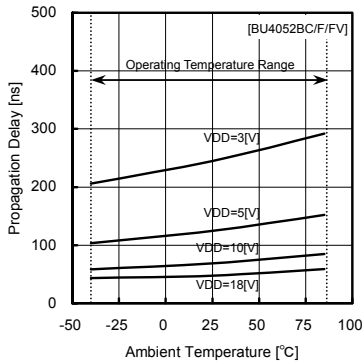

Fig.25 propagation delay time tPZL (CONT—OUT)

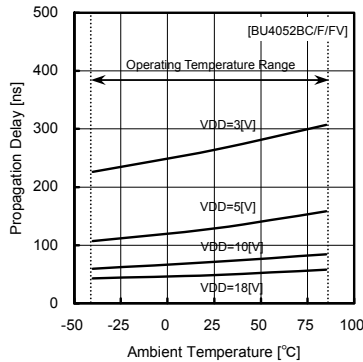

Fig.26 propagation delay time tPZH (INH—OUT)

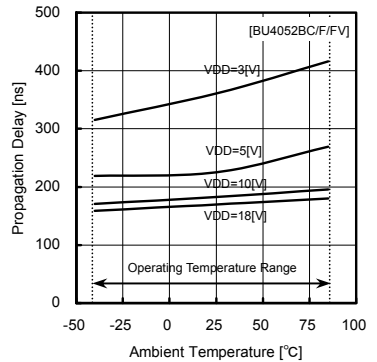

Fig.27 propagation delay time tPHZ (INH—OUT)

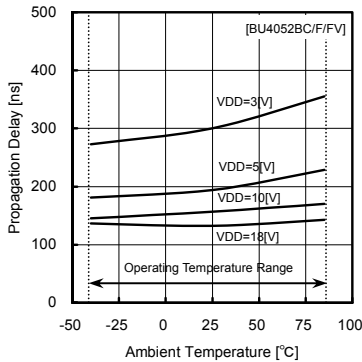

Fig.28 propagation delay time tPZL (INH—OUT)

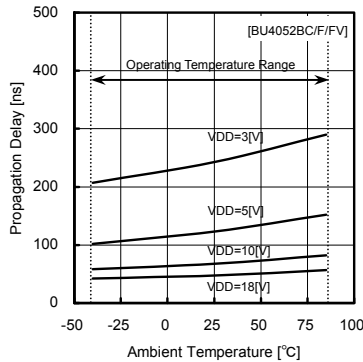

Fig.29 propagation delay time tPLZ (INH—OUT)

●Reference Data(BU4053BC)

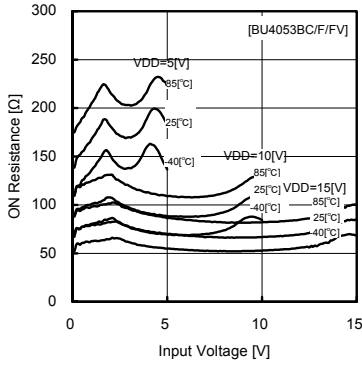

Fig.30 ON resistance—input voltage

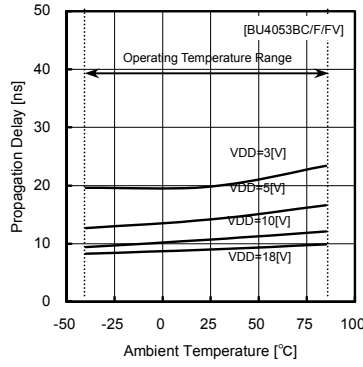

Fig.31 propagation delay time tPLH (IN—OUT)

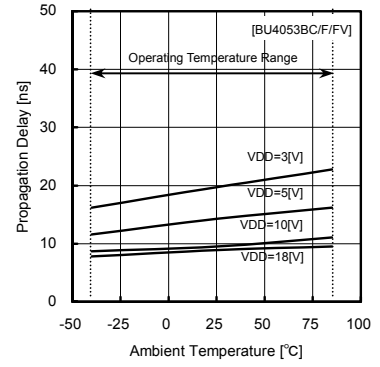

Fig.32 propagation delay time tPHL (IN—OUT)

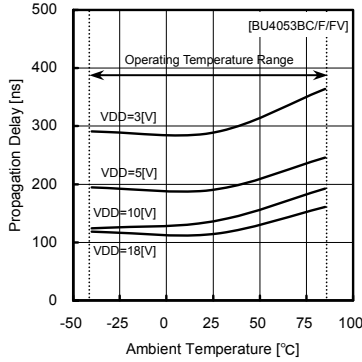

Fig.33 propagation delay time tPZH (CONT—OUT)

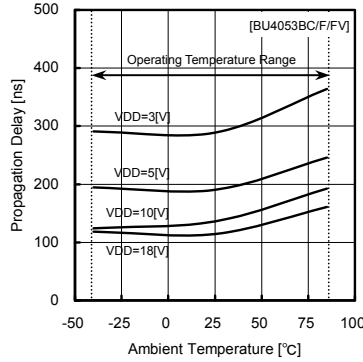

Fig.34 propagation delay time tPHZ (CONT—OUT)

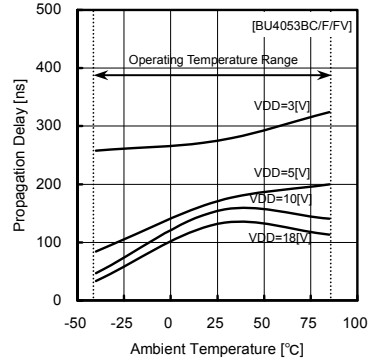

Fig.35 propagation delay time tPLZ (CONT—OUT)

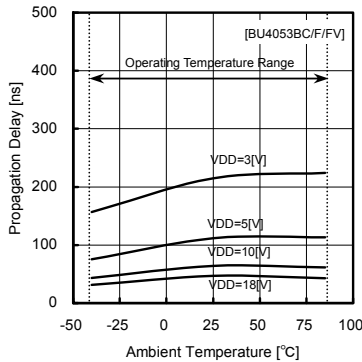

Fig.36 propagation delay time tPZL (CONT—OUT)

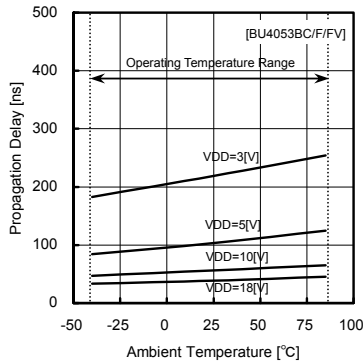

Fig.37 propagation delay time tPZH (INH—OUT)

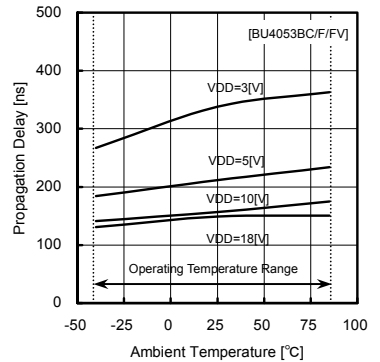

Fig.38 propagation delay time tPHZ (INH—OUT)

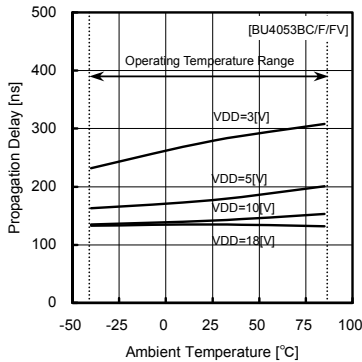

Fig.39 propagation delay time tPZL (INH—OUT)

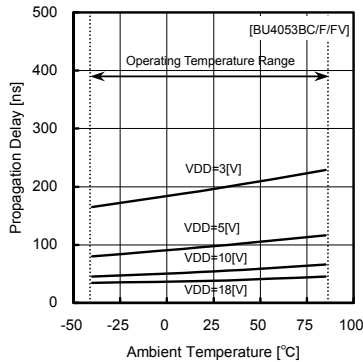

Fig.40 propagation delay time tPLZ (INH—OUT)

●Reference Data(BU4551B)

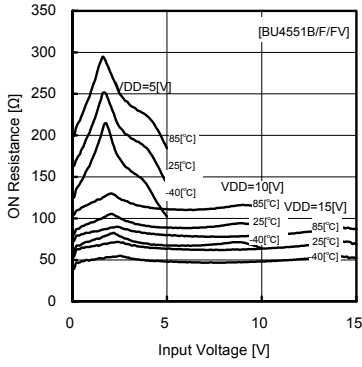

Fig.41 ON resistance – input voltage

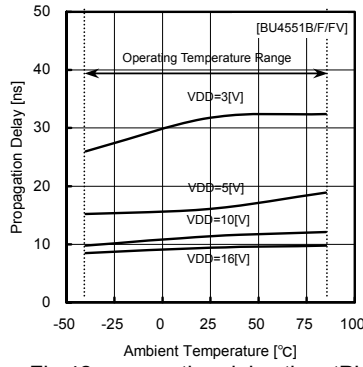

Fig.42 propagation delay time tPLH (IN – OUT)

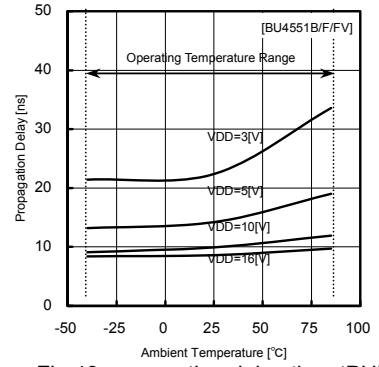

Fig.43 propagation delay time tPHL (IN – OUT)

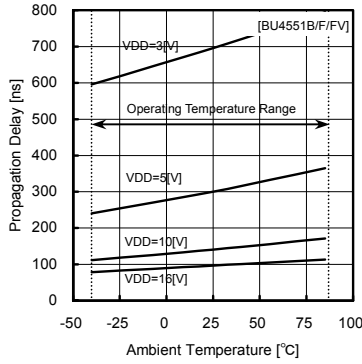

Fig.44 propagation delay time tPZH (CONT – OUT)

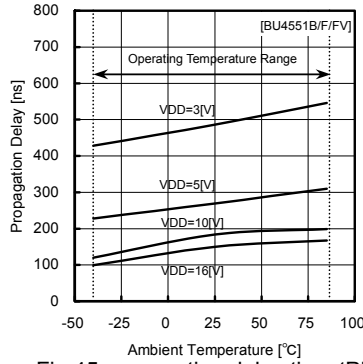

Fig.45 propagation delay time tPHZ (CONT – OUT)

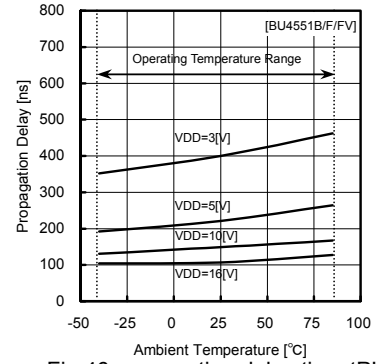

Fig.46 propagation delay time tPLZ (CONT – OUT)

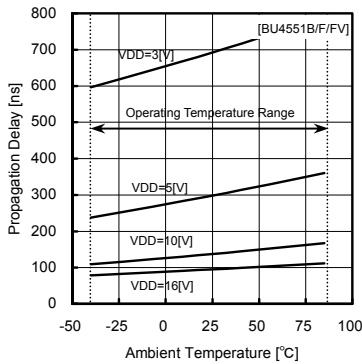
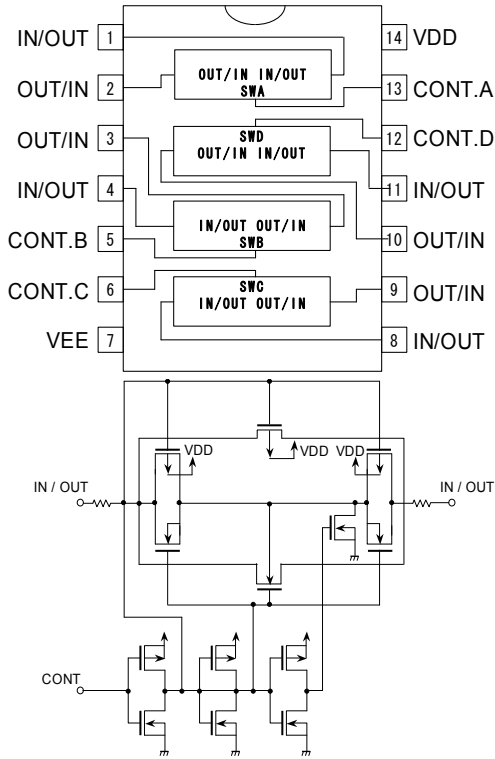

Fig.47 propagation delay time tPZL (CONT – OUT)

● Pin Configuration • Pin Function • Block Diagram • Truth Table

1) BU4066BC Series



PIN FUNCTION

PIN No.	PIN NAME	I/O	PIN FUNCTION
1	IN/OUT	I/O	Analog Switch Input / Output
2	OUT/IN	I/O	Analog Switch Input / Output
3	OUT/IN	I/O	Analog Switch Input / Output
4	IN/OUT	I/O	Analog Switch Input / Output
5	CONT.B	I	Control Input
6	CONT.C	I	Control Input
7	VEE	-	Power Supply(-)
8	IN/OUT	I/O	Analog Switch Input / Output
9	OUT/IN	I/O	Analog Switch Input / Output
10	OUT/IN	I/O	Analog Switch Input / Output
11	IN/OUT	I/O	Analog Switch Input / Output
12	CONT.D	I	Control Input
13	CONT.A	I	Control Input
14	VDD	-	Power Supply(+)

TRUTH TABLE

CONTROL	ON SWITCH
A	A(1pin-2pin)
B	B(3pin-4pin)
C	C(8pin-9pin)
D	D(10pin-11pin)

2) BU4051BC Series

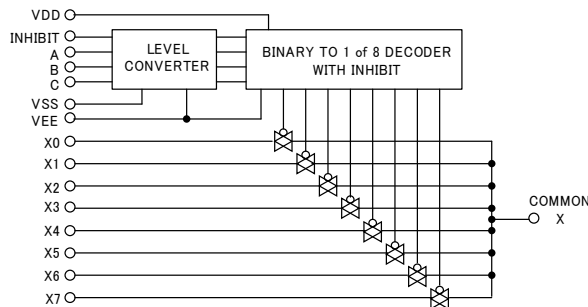
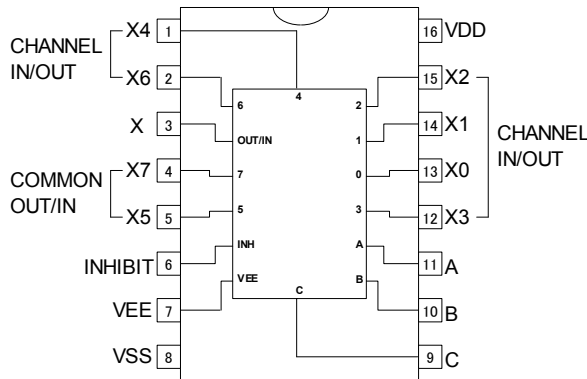

PIN FUNCTION

PIN No.	PIN NAME	I/O	PIN FUNCTION
1	X4	I/O	Analog Switch Input / Output
2	X6	I/O	Analog Switch Input / Output
3	X	I/O	Analog Switch Input / Output
4	X7	I/O	Analog Switch Input / Output
5	X5	I/O	Analog Switch Input / Output
6	INHIBIT	I	Control Input
7	VEE	-	Power Supply(-)
8	VSS	-	Power Supply(-)
9	C	I	Control Input
10	B	I	Control Input
11	A	I	Control Input
12	X3	I/O	Analog Switch Input / Output
13	X0	I/O	Analog Switch Input / Output
14	X1	I/O	Analog Switch Input / Output
15	X2	I/O	Analog Switch Input / Output
16	VDD	-	Power Supply(+)

TRUTH TABLE

INHIBIT	A	B	C	ON SWITCH
L	L	L	L	X0
L	H	L	L	X1
L	L	H	L	X2
L	H	H	L	X3
L	L	L	H	X4
L	H	L	H	X5
L	L	H	H	X6
L	H	H	H	X7
H	X	X	X	NONE

3) BU4052BC Series

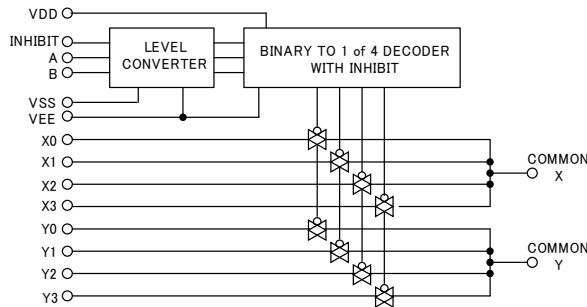
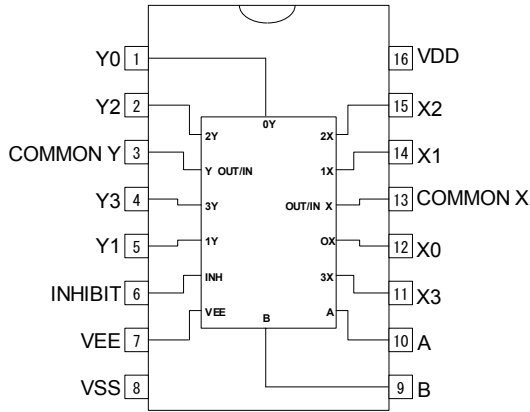

PIN FUNCTION

PIN No.	PIN NAME	I/O	PIN FUNCTION
1	Y0	I/O	Analog Switch Input / Output
2	Y2	I/O	Analog Switch Input / Output
3	COMMON Y	I/O	Analog Switch Input / Output
4	Y3	I/O	Analog Switch Input / Output
5	Y1	I/O	Analog Switch Input / Output
6	INHIBIT	I	Control Input
7	VEE	-	Power Supply(-)
8	VSS	-	Power Supply(-)
9	B	I	Control Input
10	A	I	Control Input
11	X3	I/O	Analog Switch Input / Output
12	X0	I/O	Analog Switch Input / Output
13	COMMON X	I/O	Analog Switch Input / Output
14	X1	I/O	Analog Switch Input / Output
15	X2	I/O	Analog Switch Input / Output
16	VDD	-	Power Supply(+)

TRUTH TABLE

INHIBIT	A	B	ON SWITCH
L	L	L	X0, Y0
L	H	L	X1, Y1
L	L	H	X2, Y2
L	H	H	X3, Y3
H	X	X	NONE

4) BU4053BC Series

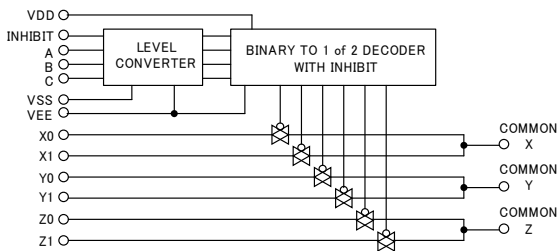
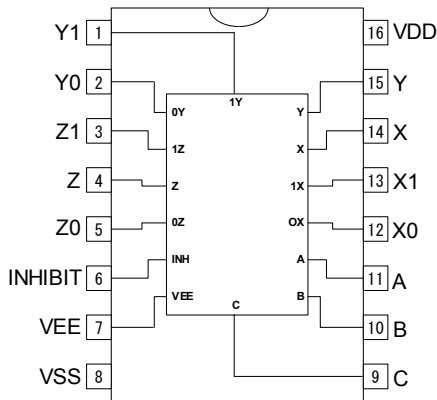

PIN FUNCTION

PIN No.	PIN NAME	I/O	PIN FUNCTION
1	Y1	I/O	Analog Switch Input / Output
2	Y0	I/O	Analog Switch Input / Output
3	Z1	I/O	Analog Switch Input / Output
4	Z	I/O	Analog Switch Input / Output
5	Z0	I/O	Analog Switch Input / Output
6	INHIBIT	I	Control Input
7	VEE	-	Power Supply(-)
8	VSS	-	Power Supply(-)
9	C	I	Control Input
10	B	I	Control Input
11	A	I	Analog Switch Input / Output
12	X0	I/O	Analog Switch Input / Output
13	X1	I/O	Analog Switch Input / Output
14	X	I/O	Analog Switch Input / Output
15	Y	I/O	Analog Switch Input / Output
16	VDD	-	Power Supply(+)

TRUTH TABLE

INHIBIT	A	B	C	ON SWITCH
L	L	L	L	X0, Y0, Z0
L	H	L	L	X1, Y0, Z0
L	L	H	L	X0, Y1, Z0
L	H	H	L	X1, Y1, Z0
L	L	L	H	X0, Y0, Z1
L	H	L	H	X1, Y0, Z1
L	L	H	H	X0, Y1, Z1
L	H	H	H	X1, Y1, Z1
H	X	X	X	NONE

5) BU4551B Series

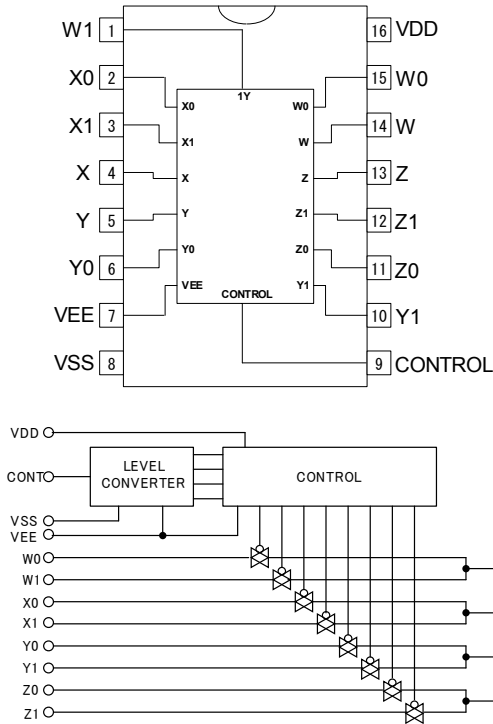

PIN FUNCTION

PIN No.	PIN NAME	I/O	PIN FUNCTION
1	W1	I/O	Analog Switch Input / Output
2	X0	I/O	Analog Switch Input / Output
3	X1	I/O	Analog Switch Input / Output
4	X	I/O	Analog Switch Input / Output
5	Y	I/O	Analog Switch Input / Output
6	Y0	I/O	Control Input
7	VEE	-	Power Supply(-)
8	VSS	-	Power Supply(-)
9	CONTROL	I	Control Input
10	Y1	I/O	Control Input
11	Z0	I/O	Analog Switch Input / Output
12	Z1	I/O	Analog Switch Input / Output
13	Z	I/O	Analog Switch Input / Output
14	W	I/O	Analog Switch Input / Output
15	W0	I/O	Analog Switch Input / Output
16	VDD	-	Power Supply(+)

TRUTH TABLE

CONTROL	ON SWITCH
0	W0,X0,Y0,Z0
1	W1,X1,Y1,Z1

●Notes for use

1. Absolute maximum ratings

An excess in the absolute maximum ratings, such as supply voltage, temperature range of operating conditions, etc., can break down the devices, thus making impossible to identify breaking mode, such as short circuit or an open circuit. If any over rated values will expect to exceed the absolute maximum ratings, consider adding circuit protection devices, such as fuses.

2. Connecting the power supply connector backward

Connecting of the power supply in reverse polarity can damage IC. Take precautions when connecting the power supply lines. An external direction diode can be added.

3. Power Supply lines

Design PCB layout pattern to provide low impedance GND and supply lines. To obtain a low noise ground and supply line, separate the ground section and supply lines of the digital and analog blocks. Furthermore, for all power terminals to ICs, connect a capacitor between the power supply and the GND terminal. When applying electrolytic capacitors in the circuit, not that capacitance characteristic values are reduced at low temperatures.

4. GND voltage

The potential of GND pin must be minimum potential in all operating conditions.

5. Thermal design

Use a thermal design that allows for a sufficient margin in light of the power dissipation (Pd) in actual operating conditions.

6. Inter-pin shorts and mounting errors

Use caution when positioning the IC for mounting on printed circuit boards. The IC may be damaged if there is any connection error or if pins are shorted together.

7. Actions in strong electromagnetic field

Use caution when using the IC in the presence of a strong electromagnetic field as doing so may cause the IC to malfunction.

8. Testing on application boards

When testing the IC on an application board, connecting a capacitor to a pin with low impedance subjects the IC to stress. Always discharge capacitors after each process or step. Always turn the IC's power supply off before connecting it to or remove it from a jig or fixture during the inspection process. Ground the IC during assembly steps as an antistatic measure. Use similar precaution when transporting or storing the IC.

9. Ground Wiring Pattern

When using both small signal and large current GND patterns, it is recommended to isolate the two ground patterns, placing a signal ground point at the ground potential of application so that the pattern wiring resistance and voltage variations caused by large currents do not cause variations in the small signal ground voltage. Be careful not to change the GND wiring pattern of any external components, either.

● Ordering part number

B	U	4	5	5	1	B	F	V	-	E	2
Part No.		Part No.		Part No.		Package		Packaging and forming specification			
		4066BC		4053BC		None: DIP14, DIP16		E2: Embossed tape and reel			
		4051BC		4551B		F : SOP14, SOP16		None: Tray, Tube			
		4052BC				FV : SSOP-B14					
						SSOP-B16					

SOP14

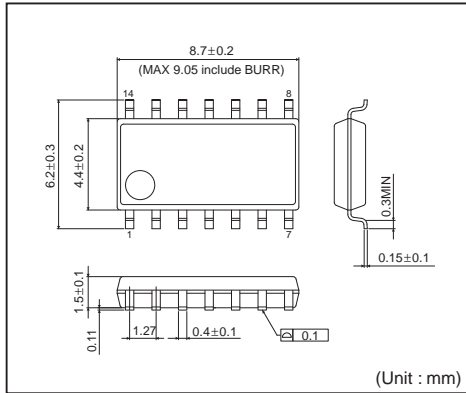

<Tape and Reel information>

Tape	Embossed carrier tape
Quantity	2500pcs
Direction of feed	E2 (The direction is the 1 pin of product is at the upper left when you hold reel on the left hand and you pull out the tape on the right hand)

Reel, 1 pin, Direction of feed

\* Order quantity needs to be multiple of the minimum quantity.

SSOP-B14

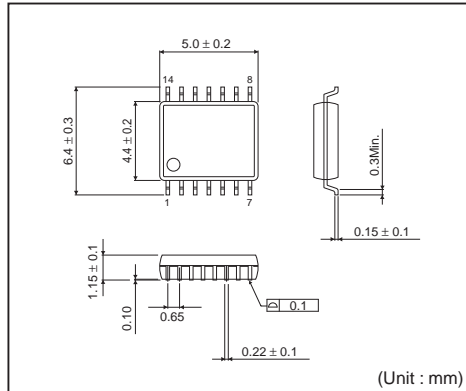

<Tape and Reel information>

Tape	Embossed carrier tape
Quantity	2500pcs
Direction of feed	E2 (The direction is the 1 pin of product is at the upper left when you hold reel on the left hand and you pull out the tape on the right hand)

Reel, 1 pin, Direction of feed

\* Order quantity needs to be multiple of the minimum quantity.

DIP14

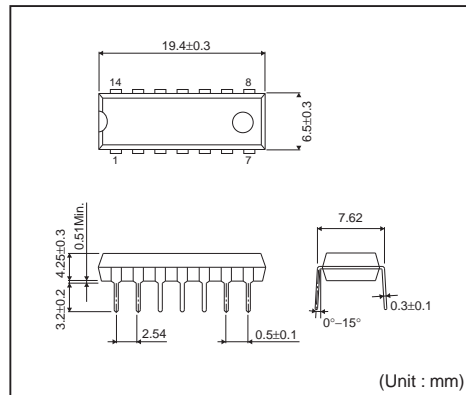

<Tape and Reel information>

Container	Tube
Quantity	1000pcs
Direction of feed	Direction of products is fixed in a container tube

\* Order quantity needs to be multiple of the minimum quantity.



**SOP16**

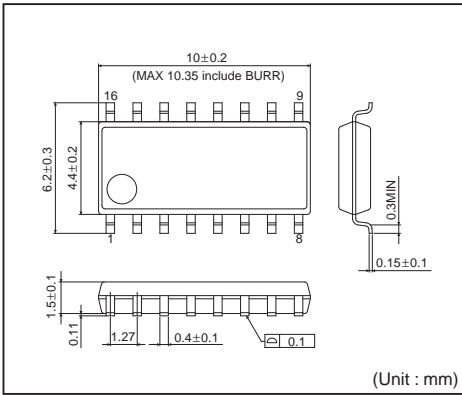

<Tape and Reel information>

Tape	Embossed carrier tape
Quantity	2500pcs
Direction of feed	E2 (The direction is the 1pin of product is at the upper left when you hold reel on the left hand and you pull out the tape on the right hand)

1pin  
\*Order quantity needs to be multiple of the minimum quantity.

**SSOP-B16**

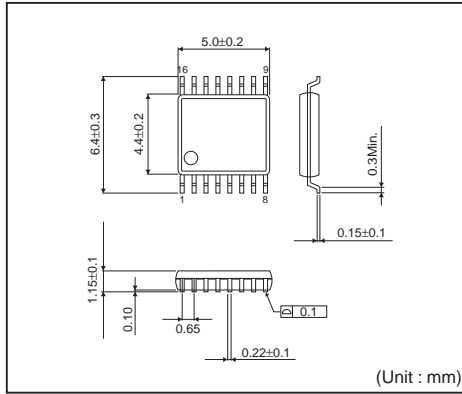

<Tape and Reel information>

Tape	Embossed carrier tape
Quantity	2500pcs
Direction of feed	E2 (The direction is the 1pin of product is at the upper left when you hold reel on the left hand and you pull out the tape on the right hand)

1pin  
\*Order quantity needs to be multiple of the minimum quantity.

**DIP16**

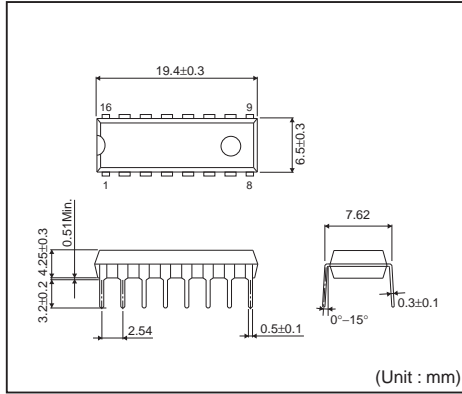

<Tape and Reel information>

Container	Tube
Quantity	1000pcs
Direction of feed	Direction of products is fixed in a container tube

\*Order quantity needs to be multiple of the minimum quantity.

## Notes

No copying or reproduction of this document, in part or in whole, is permitted without the consent of ROHM Co.,Ltd.

The content specified herein is subject to change for improvement without notice.

The content specified herein is for the purpose of introducing ROHM's products (hereinafter "Products"). If you wish to use any such Product, please be sure to refer to the specifications, which can be obtained from ROHM upon request.

Examples of application circuits, circuit constants and any other information contained herein illustrate the standard usage and operations of the Products. The peripheral conditions must be taken into account when designing circuits for mass production.

Great care was taken in ensuring the accuracy of the information specified in this document. However, should you incur any damage arising from any inaccuracy or misprint of such information, ROHM shall bear no responsibility for such damage.

The technical information specified herein is intended only to show the typical functions of and examples of application circuits for the Products. ROHM does not grant you, explicitly or implicitly, any license to use or exercise intellectual property or other rights held by ROHM and other parties. ROHM shall bear no responsibility whatsoever for any dispute arising from the use of such technical information.

The Products specified in this document are intended to be used with general-use electronic equipment or devices (such as audio visual equipment, office-automation equipment, communication devices, electronic appliances and amusement devices).

The Products specified in this document are not designed to be radiation tolerant.

While ROHM always makes efforts to enhance the quality and reliability of its Products, a Product may fail or malfunction for a variety of reasons.

Please be sure to implement in your equipment using the Products safety measures to guard against the possibility of physical injury, fire or any other damage caused in the event of the failure of any Product, such as derating, redundancy, fire control and fail-safe designs. ROHM shall bear no responsibility whatsoever for your use of any Product outside of the prescribed scope or not in accordance with the instruction manual.

The Products are not designed or manufactured to be used with any equipment, device or system which requires an extremely high level of reliability the failure or malfunction of which may result in a direct threat to human life or create a risk of human injury (such as a medical instrument, transportation equipment, aerospace machinery, nuclear-reactor controller, fuel-controller or other safety device). ROHM shall bear no responsibility in any way for use of any of the Products for the above special purposes. If a Product is intended to be used for any such special purpose, please contact a ROHM sales representative before purchasing.

If you intend to export or ship overseas any Product or technology specified herein that may be controlled under the Foreign Exchange and the Foreign Trade Law, you will be required to obtain a license or permit under the Law.



Thank you for your accessing to ROHM product informations.  
More detail product informations and catalogs are available, please contact us.

### ROHM Customer Support System

<http://www.rohm.com/contact/>