

FEATURES

- -55°C to +85° C operation
- 9 to 16 or 16 to 36 VDC input
- Fully isolated
- Opto-coupler feedback
- Fixed frequency, 250 kHz typical
- Topology – Push-Pull Forward
- 50 V for 50 ms transient protection
- Inhibit function
- Indefinite short circuit protection
- Up to 79% efficiency

DC/DC CONVERTERS 12 & 28 VOLT INPUT



MTO SERIES 15 WATT

MODELS
VDC OUTPUT
TRIPLE
+5 & ±12
+5 & ±15

Size (max.): Non-flanged, case F4, 1.950 x 1.350 x 0.505 inches (49.53 x 34.29 x 12.83 mm)
Flanged, case J5, 2.720 x 1.350 x 0.505 inches (69.09 x 34.29 x 12.83 mm)
See Section B8, cases F4 and J5, for dimensions.

Weight: 53 grams typical

Screening: Standard or ES. See Section C2 for screening options, see Section A5 for ordering information.

DESCRIPTION

Interpoint's MTO Series™ of DC/DC converters delivers 15 watts of output power with three output voltages and a choice of two input voltage ranges. The MTO Series converters are packaged in hermetically sealed metal cases and operate at full load over a case temperature range of -55°C to +85°C (measured at the base plate of the converter).

CONVERTER DESIGN

The push-pull forward topology coupled with pulse-width modulation minimizes output noise and maintains good regulation. Nominal switching frequency is 250 kHz. Although an internal input filter reduces input ripple current, for applications requiring conformance to MIL-STD-461C, CE03, use the MTO in conjunction with Interpoint's FM-461 EMI filter.

Operating at maximum ratings may require removing self-generated heat. To increase heat dissipation, heat conducting material can be used in contact with the converter's base plate. Interpoint's Thermal Mounting Pad (TMP), model TMP-002, is designed for use with the MTO converter.

FEATURES

An inhibit terminal, pin 8, provides shut-down and start-up control. Applying a logic low (<0.8 V) will disable the output of the converter reducing input current to 8 mA, typical. Leaving the terminal unconnected or connecting it to Vin will enable the converter. The inhibit pin has an open circuit voltage of approximately 10 volts.

Soft-start provides a controlled 20 milliseconds turn-on to minimize inrush current and reduce overshoot at initial start-up or when inhibit is released.

Internal current limiting circuitry protects all three outputs against short circuits. When output power exceeds approximately 125% of maximum output power, the output currents are limited. In addition, separate current limiting circuitry protects each output individually.

PACKAGING

MTO converters are packaged in hermetically sealed metal cases. The cases are constructed of cold-rolled steel with a fused tin finish. MTO converters can be purchased in a flanged or non-flanged case. The flanged option provides increased heat dissipation and also provides greater stability when mechanically secured.

CRANE

interpoint
A CRANE CO. COMPANY

B4-23

MTO SERIES 15 WATT

DC/DC CONVERTERS

ABSOLUTE MAXIMUM RATINGS

Output Power

- 15 watts

Lead Soldering Temperature (10 sec per lead)

- 300°C

Storage Temperature Range (Case)

- -65°C to +125°C

INHIBIT

Inhibit TTL Open Collector

- Logic low (output disabled)
V = <0.8 V
- Inhibit pin current < 2.0 mA
- Referenced to input common
- Logic high (output enabled)
Unconnected or connected to Vin

TYPICAL CHARACTERISTICS

Output Voltage Temperature Coefficient

- 150 ppm/°C typical

Input to Output Capacitance

- 80 pF typical

Current Limit

- 125% of full load typical

Isolation

- 100 megohm minimum at 500 V

Conversion Frequency

- 250 kHz typical

Inhibit Pin Voltage (unit enabled)

- 10 V typical

RECOMMENDED OPERATING CONDITIONS

Input Voltage Range

- MTO12XXT 9 to 16 VDC continuous
- MTO28XXT 16 to 36 VDC continuous
- MTO12XXT 25 V for 50 msec transient
- MTO28XXT 50 V for 50 msec transient

Case Operating Temperature (Tc)

- -55°C to +85°C full power
- -55°C to +115°C absolute

Derating Output Power/Current

- Linearly from 100% at 85°C to 0% at 115°C

Electrical Characteristics: 25°C Tc, 28 VDC Vin (12 VDC for 12V models), 100% load, unless otherwise specified.

PARAMETER	CONDITION	MTO1212T			MTO1215T			MTO2812T			MTO2815T			UNITS
		MIN	TYP	MAX	MIN	TYP	MAX	MIN	TYP	MAX	MIN	TYP	MAX	
OUTPUT VOLTAGE	MAIN	4.95	5.0	5.05	4.95	5.0	5.05	4.95	5.0	5.05	4.95	5.0	5.05	VDC
	+ AUXILIARY	11.88	12.0	12.12	14.85	15.0	15.15	11.88	12.0	12.12	14.85	15.0	15.15	
	- AUXILIARY	11.88	12.0	12.12	14.85	15.0	15.15	11.88	12.0	12.12	14.85	15.0	15.15	
OUTPUT CURRENT	MAIN ¹	100	—	2000	100	—	2000	100	—	2000	100	—	2000	mA
	AUXILIARY	—	—	±208	—	—	±167	—	—	±208	—	—	±167	
OUTPUT POWER	MAIN	—	—	10.0	—	—	10.0	—	—	10.0	—	—	10.0	W
	+ AUXILIARY	—	—	2.5	—	—	2.5	—	—	2.5	—	—	2.5	
	- AUXILIARY	—	—	2.5	—	—	2.5	—	—	2.5	—	—	2.5	
	TOTAL	—	—	15	—	—	15	—	—	15	—	—	15	
OUTPUT RIPPLE VOLTAGE, BW = 1 MHz	MAIN	—	—	80	—	—	80	—	—	80	—	—	80	mV p-p
	± AUXILIARY	—	—	30	—	—	30	—	—	30	—	—	30	
LINE REGULATION Vin = MIN. TO MAX.	MAIN	—	5	10	—	5	10	—	5	10	—	5	10	mV
	±AUXILIARY	—	30	48	—	30	60	—	30	48	—	30	60	
LOAD REGULATION NO LOAD TO FULL	MAIN	—	10	20	—	10	20	—	10	20	—	10	20	mV
	± AUXILIARY	—	30	48	—	30	60	—	30	48	—	30	60	
INPUT VOLTAGE	CONTINUOUS	9	12	16	9	12	16	16	28	36	16	28	36	VDC
	TRANSIENT 50 ms	—	—	25	—	—	25	—	—	50	—	—	50	
INPUT CURRENT	NO LOAD	—	—	60	—	—	60	—	—	30	—	—	30	mA
	FULL LOAD	—	—	1670	—	—	1670	—	—	700	—	—	700	
	INHIBITED	—	8	10	—	8	10	—	8	10	—	8	10	
INPUT RIPPLE CURRENT		—	50	100	—	50	100	—	20	50	—	20	50	mA p-p
EFFICIENCY		76	79	—	76	79	—	76	79	—	76	79	—	%

Note
1. Minimum load required for full output capability on auxiliary outputs. Minimum current can be reduced when dual outputs are used at reduced loads.

DC/DC CONVERTERS

MTO SERIES
15 WATT

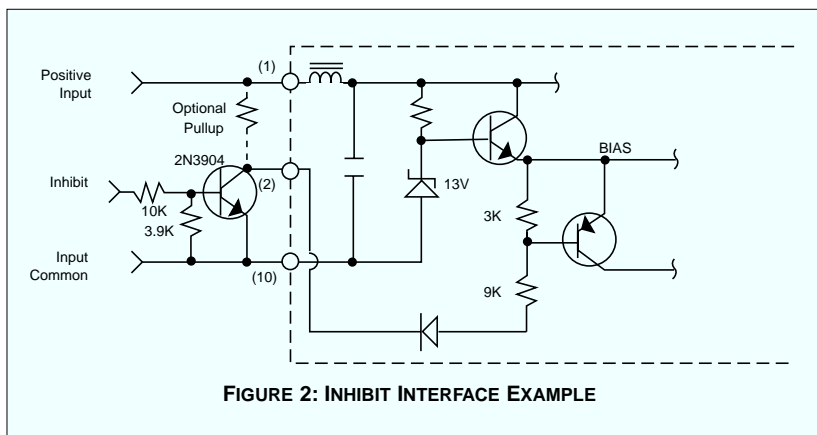
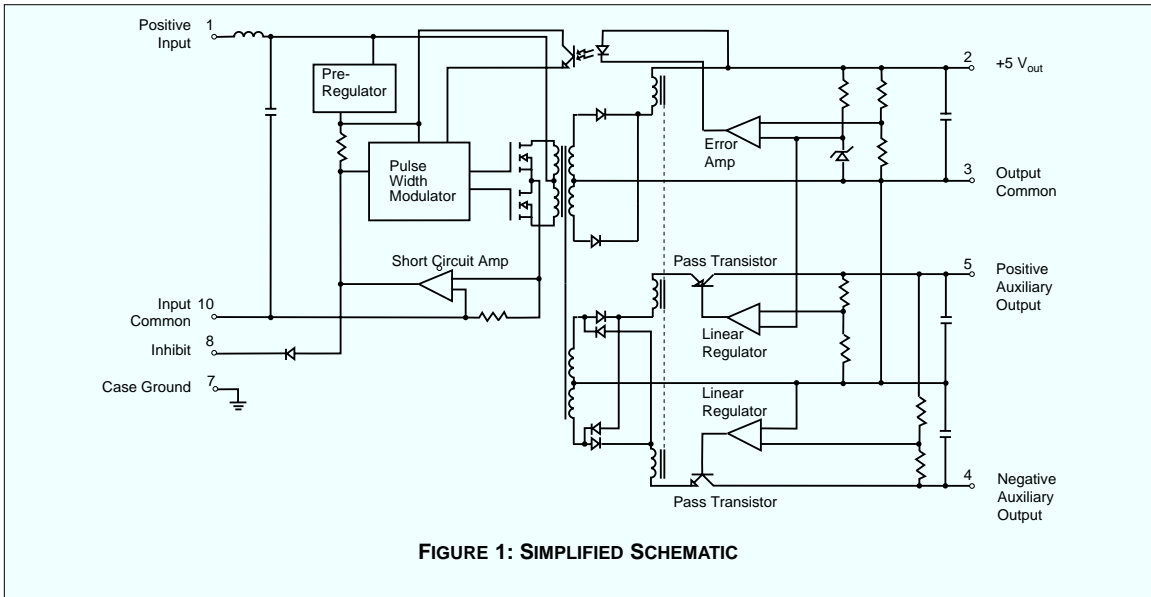

MTO SERIES 15 WATT

DC/DC CONVERTERS

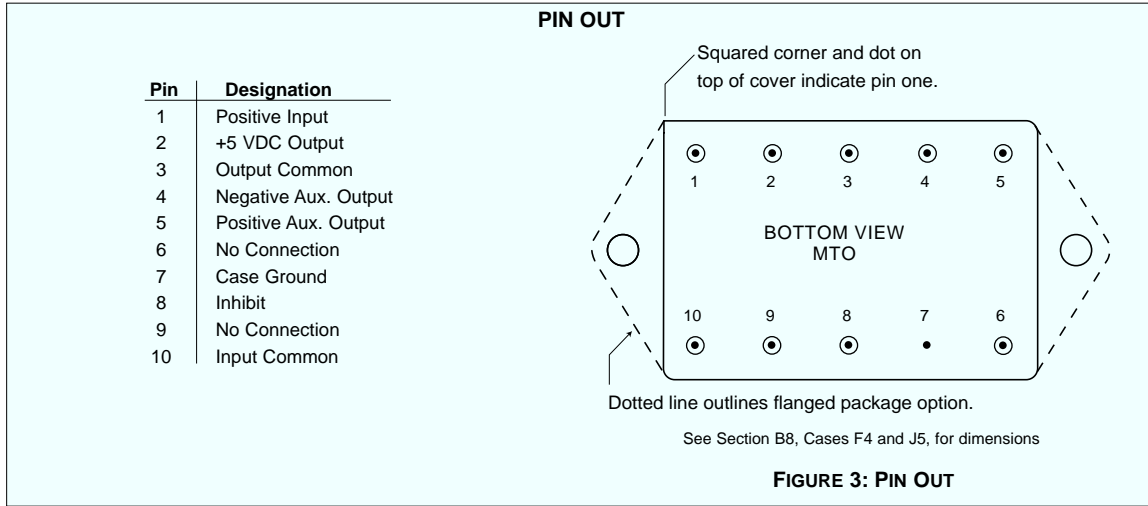

Typical Performance Curve: 25°C Tc

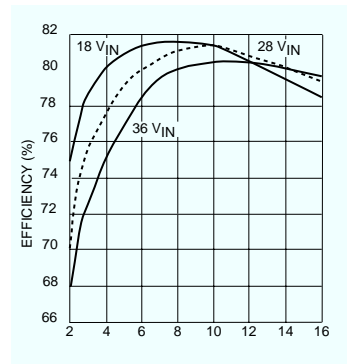
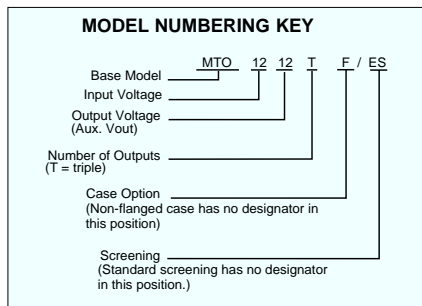

Output Power (Watts)
Representative of all models
MTO2815T Efficiency

FIGURE 4

B4-26

24223-001-DTS Rev A DQ# 1021
All technical information is believed to be accurate, but no responsibility is assumed for errors or omissions. Interpoint reserves the right to make changes in products or specifications without notice. MTO Series is a trademark of Interpoint. Copyright © 1990 - 1999 Interpoint. All rights reserved.



CASE F

CASES

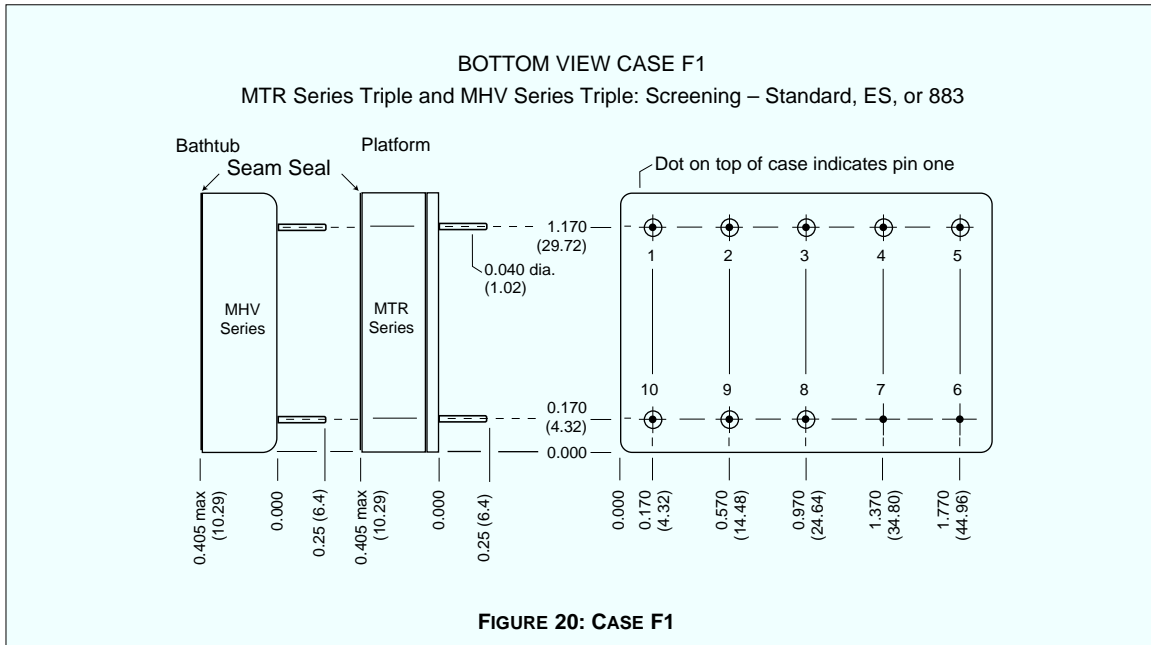
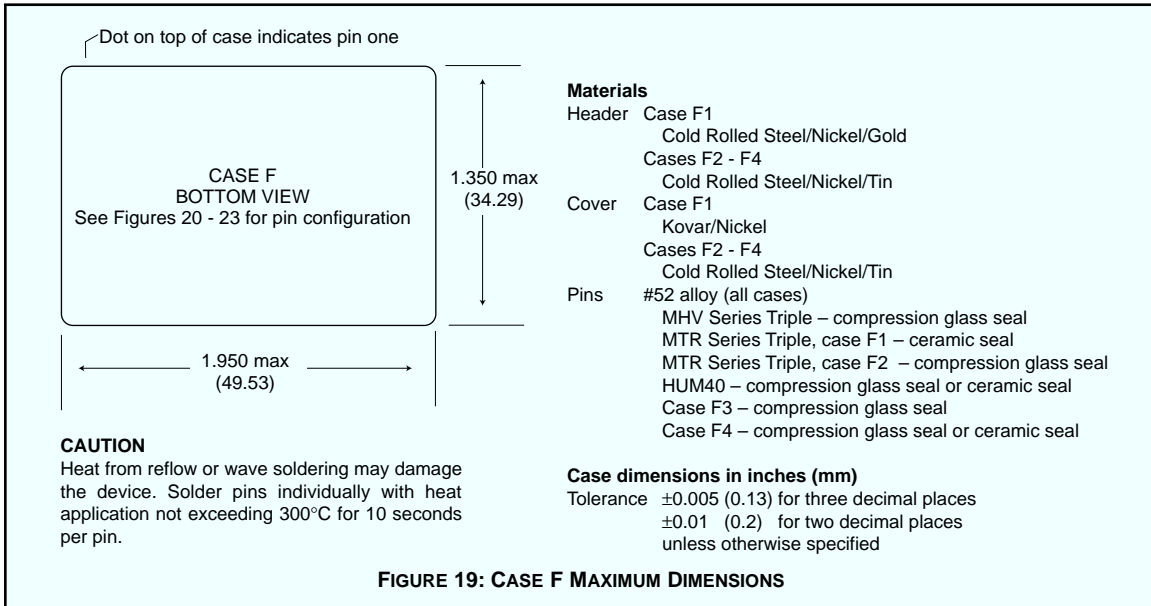

Note: Although every effort has been made to render the case drawings at actual size, variations in the printing process may cause some distortion. Please refer to the numerical dimensions for accuracy.

CASE F

CASES

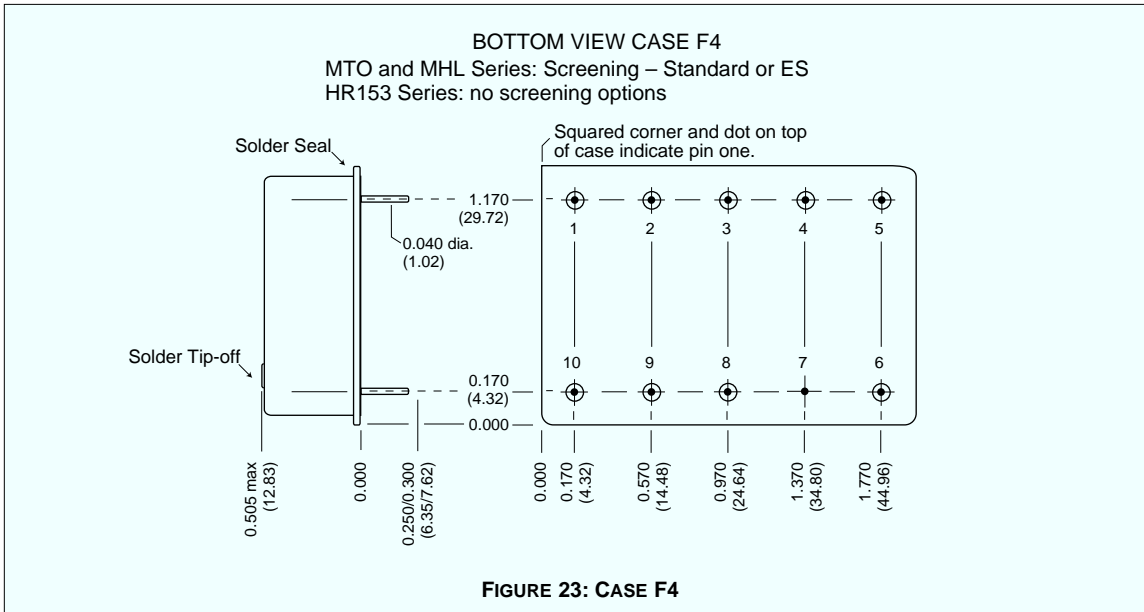

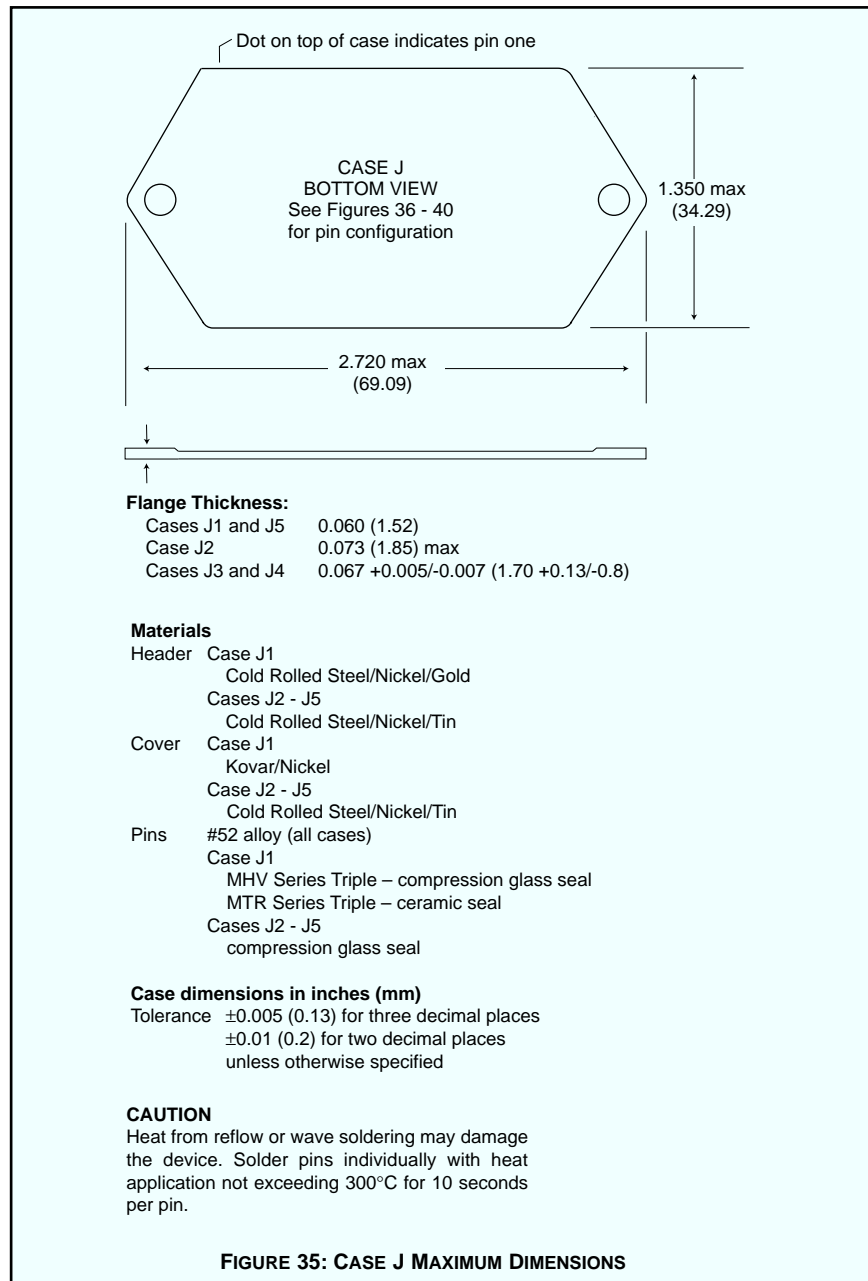

Note: Although every effort has been made to render the case drawings at actual size, variations in the printing process may cause some distortion. Please refer to the numerical dimensions for accuracy.

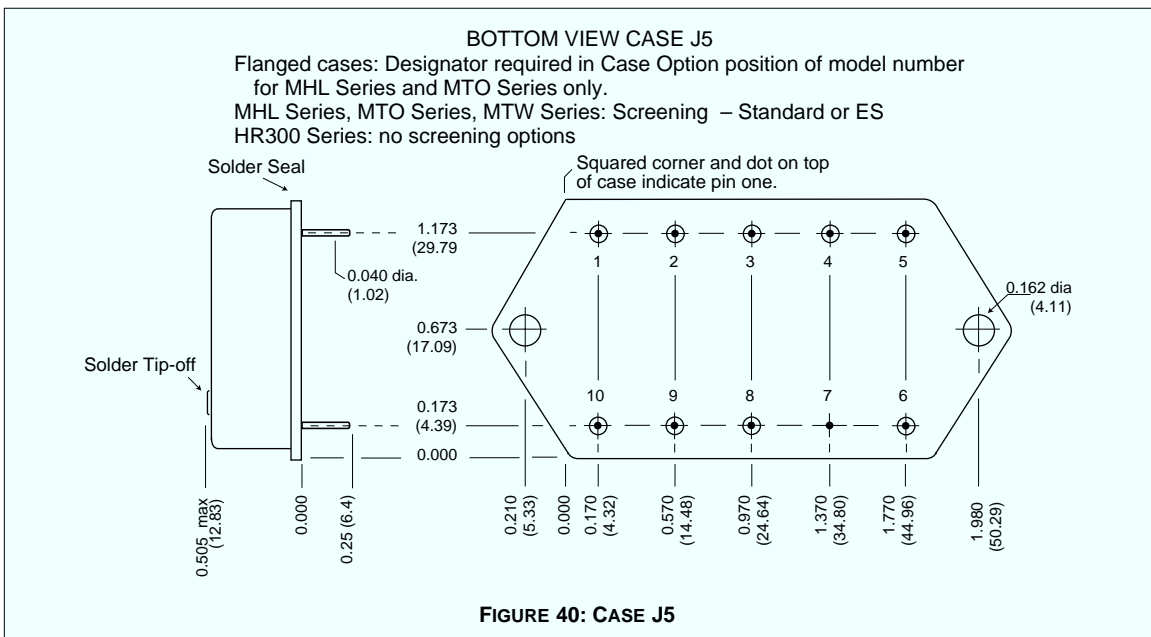
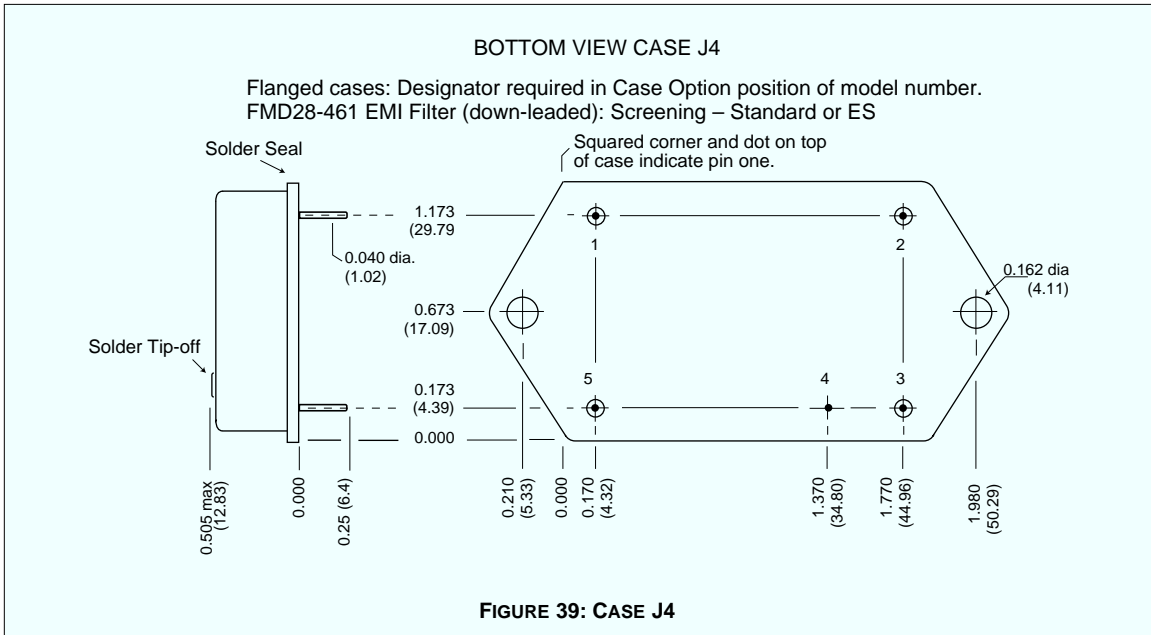

QA SCREENING 85°C PRODUCTS

85°C PRODUCTS

TEST (85°C Products excluding HR products)	STANDARD	/ES
PRE-CAP INSPECTION Method 2017	yes	yes
TEMPERATURE CYCLE (10 times) Method 1010, Cond. B, -55°C to 125°C	no	yes
CONSTANT ACCELERATION Method 2001, 500 g	no	yes
BURN-IN 96 hours at 70°C ambient (typical)	no	yes
FINAL ELECTRICAL TEST MIL-PRF-38534, Group A Subgroups 1 and 4: +25°C case	yes	yes
HERMETICITY TESTING Fine Leak, Method 1014, Cond. A Gross Leak, Method 1014, Cond. C Gross Leak, Dip (1 x 10 ⁻³)	no no yes	yes yes no
FINAL VISUAL INSPECTION Method 2009	yes	yes

Test methods are referenced to MIL-STD-883 as determined by MIL-PRF-38534.

Applies to the following products:

MFW Series
MTW Series
MHE/MLP Series
MHL Series
MRH Series
MTO Series
MSR Series
DCH Series
FM/FMA/FMB EMI Filters
MSF EMI Filter