



**PRELIMINARY INFORMATION**

**2 V Dual-Mode WCDMA & Dual-Band GSM/DCS Switch  
0.5 – 2.0 GHz**

**SW-488  
Rev 1.2**

**Features**

- GSM Power Handling with +2.0 V Control Voltage
- Low Power Consumption. Less than 1µA current in Receive mode.
- Integrated Decoder.
- Leadless 4 x 4mm FQFP-N, 20 Pin Package.
- Low Insertion Loss, 0.3 dB in GSM Transmit mode.

**Description**

The M/A-COM SW-488 is a GaAs monolithic switch in a low cost, FQFP-N, surface mount plastic package. The SW-488 is ideally suited for applications where very low power consumption, high power handling, and low cost are required. The SW-488 includes an integrated decoder. The switch offers GSM power handling with below +2.5V control voltage. The supply voltage VDD should be connected to the highest available voltage.

The SW-488 is fabricated using a new 0.5-micron gate length GaAs pHEMT process. The process features full chip passivation for increased performance and reliability. This switch is designed for Dual Mode WCDMA/GSM/DCS handsets where the phone needs to be able to simultaneously receive a WCDMA and GSM signal.

**Functional Schematic**

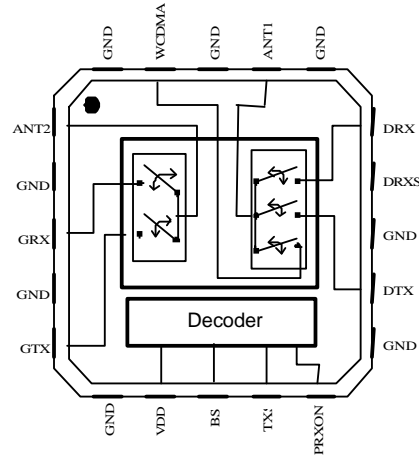

**Ordering Information**

Part Number	Description
SW-488TR	SW-488 on 1000 Piece Tape and Reel
SW-488TR-3000	SW-488 on 3000 Piece Tape and Reel
SW-488SMB	SW-488 Sample Test Board

\* If specific reel size is required, consult factory for part number assignment

The Preliminary Specifications Data Sheet Contains Typical Electrical Specifications Which May Change Prior to Final Introduction.

**M/A-COM, Inc.**

North America: Tel. (800) 366-2266  
Fax (800) 618-8883

♦ Asia/Pacific: Tel. +81 3 3263-8761  
Fax +81 3 3263-8769

♦ Europe: Tel. +44 (1344) 869-595  
Fax +44 (1344) 300-020

**ELECTRICAL CHARACTERISTICS: Test Conditions: VDD = 2.5V, Vctrl = 2.0V, TA = +25°C**

Mode	Specifications	Freq. (MHz)	Units	Min.	Typ.	Max.
ANT2 -> GSM RX	Insertion Loss	925 -960	dB	0.54	0.6	0.7
ANT1 -> UMTS Tx	Insertion Loss	1920-1980	dB	0.65	0.7	0.9
ANT1 -> UMTS Rx	Insertion Loss	2110-2170	dB	0.7	0.75	0.95
	Isolation ANT1 to DCS Tx	1710-1785	dB	22	22	22
	Isolation ANT2 to GSM Tx	880 - 915	dB	15	15	15
	Isolation UMTS to DCS Rx	1920 -1980	dB	30	30	30
	Isolation UMTS to GSM Rx	1920 -1980	dB	30	30	30
	Isolation UMTS to GSM Tx	1920 -1980	dB	30	30	30
	Isolation DCS Tx to DCS Rx	1710 - 1785	dB	30	30	30
	Isolation DCS Tx to GSM Rx	1710 - 1785	dB	30	30	30
	Isolation GSM Tx to DCS Rx	880 - 915	dB	30	30	30
	Isolation GSM Tx to GSM Rx	880 - 915	dB	15	15	15
ANT1 -> DCS RX	Insertion Loss	1805 -1880	dB	0.74	0.8	0.9
	Isolation ANT1 to DCS Tx	1710 - 1785	dB	20	20	20
	Isolation ANT2 to GSM Tx	880 - 915	dB	10	10	10
	Isolation DCS Tx to DCS Rx	1710 - 1785	dB	20	20	20
	Isolation DCS Tx to GSM Rx	1710 - 1785	dB	30	30	30
	Isolation GSM Tx to DCS Rx	880 - 915	dB	30	30	30
	Isolation GSM Tx to GSM Rx	880 - 915	dB	30	30	30
ANT2 -> GSM TX	Insertion Loss	880 - 915	dB	0.24	0.3	0.4
	Isolation GSM Tx to UMTS	880 - 915	dB	30	30	30
	Isolation GSM Tx to DCS Rx	880 - 915	dB	30	30	30
	Isolation GSM Tx to GSM Rx	880 - 915	dB	25	25	25
	Isolation DCS Tx to DCS Rx	1710 - 1785	dB	30	30	30
	Isolation DCS Tx to GSM Rx	1710 - 1785	dB	30	30	30
ANT1 -> DCS TX	Insertion Loss	1710 -1785	dB	0.54	0.6	0.7
	Isolation DCS Tx to UMTS	1710 -1785	dB	20	20	20
	Isolation DCS Tx to DCS Rx	1710 -1785	dB	30	30	30
	Isolation DCS Tx to GSM Rx	1710 -1785	dB	30	30	30
	Isolation GSM Tx to DCS Rx	880 - 915	dB	30	30	30
	Isolation GSM Tx to GSM Rx	880 - 915	dB	30	30	30
2nd Harmonics	See attached data		dBc	-84	-80	-70
3rd Harmonics	See attached data		dBc	-79	-76	-65
Supply Voltage			Volts	2.0	2.5	4.0
High Control Voltages			Volts	2.0	2.5	4.0
Low Control Voltages			Volts	-0.2	0	0.2

1. DC blocking capacitors are required on all RF and shunt ports.
2. All impedances are 50 ohms

The Preliminary Specifications Data Sheet Contains Typical Electrical Specifications Which May Change Prior to Final Introduction.

**M/A-COM, Inc.**

**2**

North America: Tel. (800) 366-2266  
Fax (800) 618-8883

◆ Asia/Pacific: Tel. +81 3 3263-8761  
Fax +81 3 3263-8769

◆ Europe: Tel. +44 (1344) 869-595  
Fax +44 (1344) 300-020

## Pin Configuration

Pin No.	Pin Name	Description
1	ANT2	GSM ANT Port
2	GND	RF Ground
3	GRX	GSM Rx Port
4	GND	RF Ground
5	GTX	GSM Tx Port
6	GND	Decoder GND
7	VDD	Decoder Vdd
8	BS	Control 1
9	TXS	Control 2
10	PRXON	Control 3
11	GND	RF Ground
12	DCS TX	DCS Tx Port
13	GND	RF Ground
14	DCSRX_S	DCS Rx Shunt
15	DCSRX	DCS Rx Port
16	GND	RF Ground
17	ANT 1	WCDMA/DCS ANT
18	GND	RF Ground
19	WCDMA	WCDMA Port
20	GND	RF Ground
21	GND	Paddle

## Block Diagram

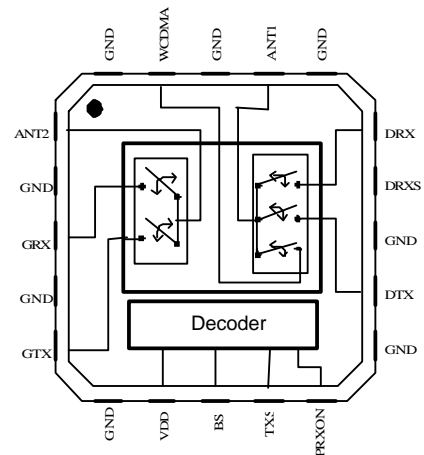

## Truth Table

BS	TXS	PRXON	MODE
0	0	0	GSM RX – ANT2 WCDMA – ANT1
0	1	0	GSM TX – ANT2
1	1	0	DCS TX – ANT1
1	0	0	DCS RX – ANT1

Logic Level	Voltage Level
VLo "0"=	0 V
VHi "1"=	2.5 V

The Preliminary Specifications Data Sheet Contains Typical Electrical Specifications Which May Change Prior to Final Introduction.

**M/A-COM, Inc.**

North America: Tel. (800) 366-2266  
Fax (800) 618-8883

♦ Asia/Pacific: Tel. +81 3 3263-8761  
Fax +81 3 3263-8769

♦ Europe: Tel. +44 (1344) 869-595  
Fax +44 (1344) 300-020

**3**

Sample Board Schematic

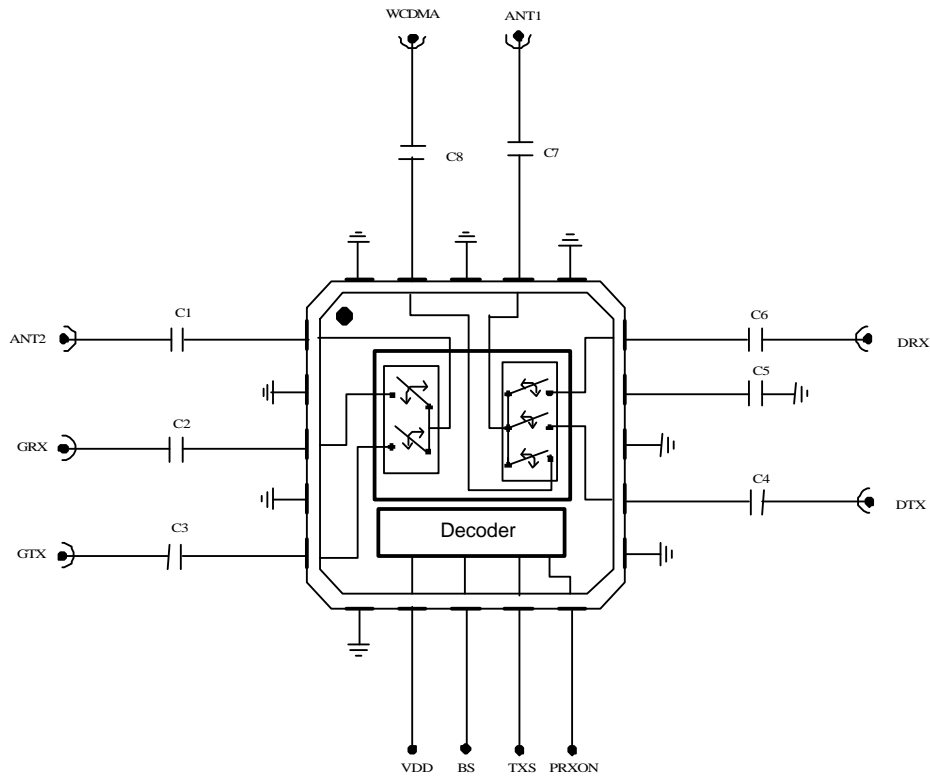

External Circuitry Parts List (Note: Values of external elements not final)

Ref. Designation	Value	Purpose
C1	22 pF	DC Block
C2	22 pF	DC Block
C3	22 pF	DC Block
C4	22 pF	DC Block
C5	4.7 pF	RF Shunt
C6	22 pF	DC Block
C7	22 pF	DC Block
C8	22 pF	DC Block

The Preliminary Specifications Data Sheet Contains Typical Electrical Specifications Which May Change Prior to Final Introduction.

M/A-COM, Inc.

North America: Tel. (800) 366-2266  
Fax (800) 618-8883

♦ Asia/Pacific: Tel. +81 3 3263-8761  
Fax +81 3 3263-8769

♦ Europe: Tel. +44 (1344) 869-595  
Fax +44 (1344) 300-020

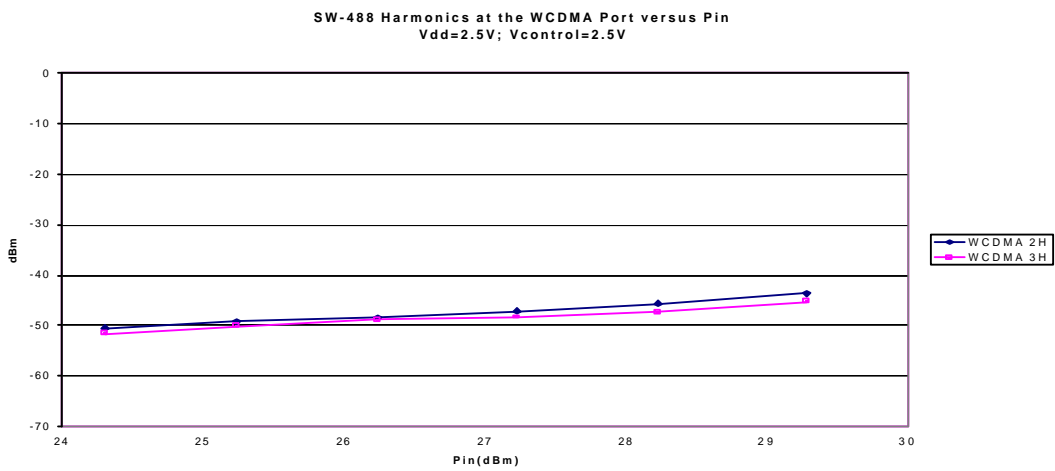
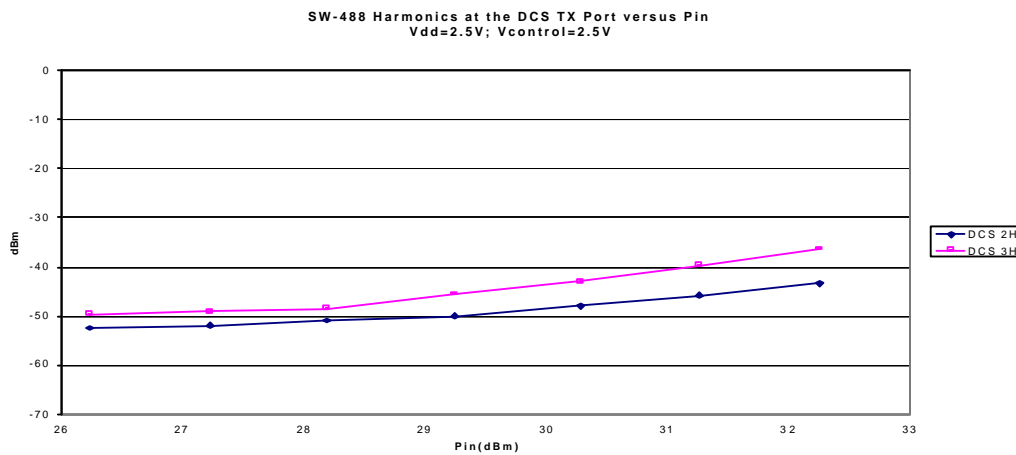
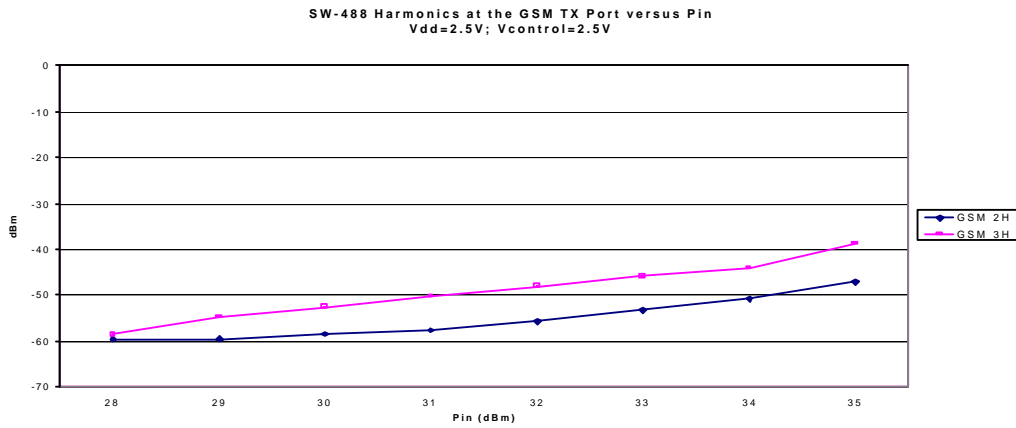

The Preliminary Specifications Data Sheet Contains Typical Electrical Specifications Which May Change Prior to Final Introduction.

M/A-COM, Inc.

North America: Tel. (800) 366-2266  
Fax (800) 618-8883

♦ Asia/Pacific: Tel. +81 3 3263-8761  
Fax +81 3 3263-8769

♦ Europe: Tel. +44 (1344) 869-595  
Fax +44 (1344) 300-020

4 mm FQFP-N, 20-Lead

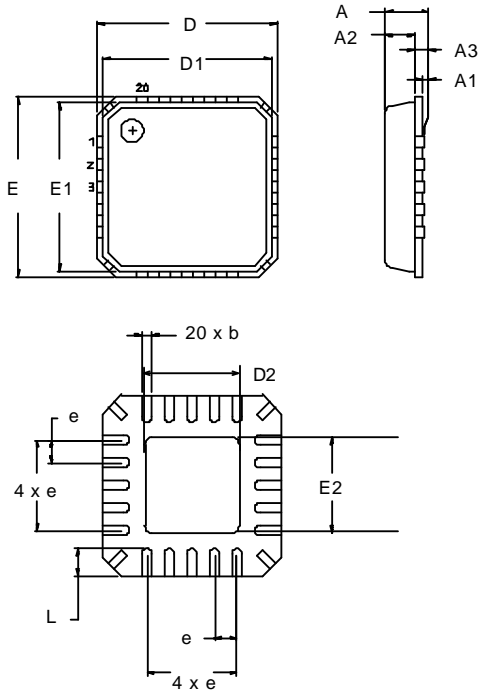

Dimension	Measurement (mm)		
	Min.	Nom.	Max.
A	0.80	0.90	1.00
A1	0	0.02	0.05
A2	0	0.65	1.00
A3		0.25 ref.	
b	0.18	0.23	0.30
D		4.00 basic	
D1		3.75 basic	
D2	0.75	1.70	2.25
e		0.50 basic	
E		4.00 basic	
E1		3.75 basic	
E2	0.75	1.70	2.25
L	0.35	0.55	0.75

**Note:** See JEDEC MO-220A VGGD-1 for additional dimensional and tolerance information

The Preliminary Specifications Data Sheet Contains Typical Electrical Specifications Which May Change Prior to Final Introduction.

**M/A-COM, Inc.**

North America: Tel. (800) 366-2266  
Fax (800) 618-8883

◆ Asia/Pacific: Tel. +81 3 3263-8761  
Fax +81 3 3263-8769

◆ Europe: Tel. +44 (1344) 869-595  
Fax +44 (1344) 300-020