

DESCRIPTION

The MGF4953A/MGF4954A super-low noise HEMT (High Electron Mobility Transistor) is designed for use in C to K band amplifiers.

The lead-less ceramic package assures minimum parasitic losses.

FEATURES

Low noise figure @ f=12GHz
 MGF4953A : NFmin. = 0.40dB (Typ.)
 MGF4954A : NFmin. = 0.60dB (Typ.)

High associated gain @ f=12GHz
 Gs = 13.5dB (Typ.)

APPLICATION

C to K band low noise amplifiers

QUALITY GRADE

GG

RECOMMENDED BIAS CONDITIONS

V_{DS}=2V , I_D=10mA

ORDERING INFORMATION

Tape & reel 3000pcs./reel

Outline Drawing

Fig.1

MITSUBISHI Proprietary

Not to be reproduced or disclosed without permission by Mitsubishi Electric

Keep Safety first in your circuit designs!

Mitsubishi Electric Corporation puts the maximum effort into making semiconductor products better and more reliable , but there is always the possibility that trouble may occur with them. Trouble with semiconductors may lead to personal injury , fire or property damage. Remember to give due consideration to safety when making your circuit designs , with appropriate measure such as (i) placement of substitutive , auxiliary circuits , (ii) use of non-flammable material or (iii) prevention against any malfunction or mishap.

ABSOLUTE MAXIMUM RATINGS (Ta=25°C)

Symbol	Parameter	Ratings	Unit
V _{GDO}	Gate to drain voltage	-4	V
V _{GSO}	Gate to source voltage	-4	V
I _D	Drain current	60	mA
PT	Total power dissipation	50	mW
T _{ch}	Channel temperature	125	°C
T _{stg}	Storage temperature	-65 to +125	°C

ELECTRICAL CHARACTERISTICS (Ta=25°C)

Synbol	Parameter	Test conditions	Limits			Unit	
			MIN.	TYP.	MAX		
V _{(BR)GDO}	Gate to drain breakdown voltage	I _G =-10μA	-3	--	--	V	
I _{GSS}	Gate to source leakage current	V _{GS} =-2V, V _{DS} =0V	--	--	50	μA	
I _{DSS}	Saturated drain current	V _{GS} =0V, V _{DS} =2V	15	--	60	mA	
V _{GS(off)}	Gate to source cut-off voltage	V _{DS} =2V, I _D =500μA	-0.1	--	-1.5	V	
gm	Transconductance	V _{DS} =2V, I _D =10mA	--	70	--	mS	
Gs	Associated gain	V _{DS} =2V,	12.0	13.5	--	dB	
NFmin.	Minimum noise figure	I _D =10mA					
		f=12GHz	MGF4953A	--	0.40	0.50	dB
			MGF4954A	--	0.60	0.80	dB

Fig.1

Unit : mm

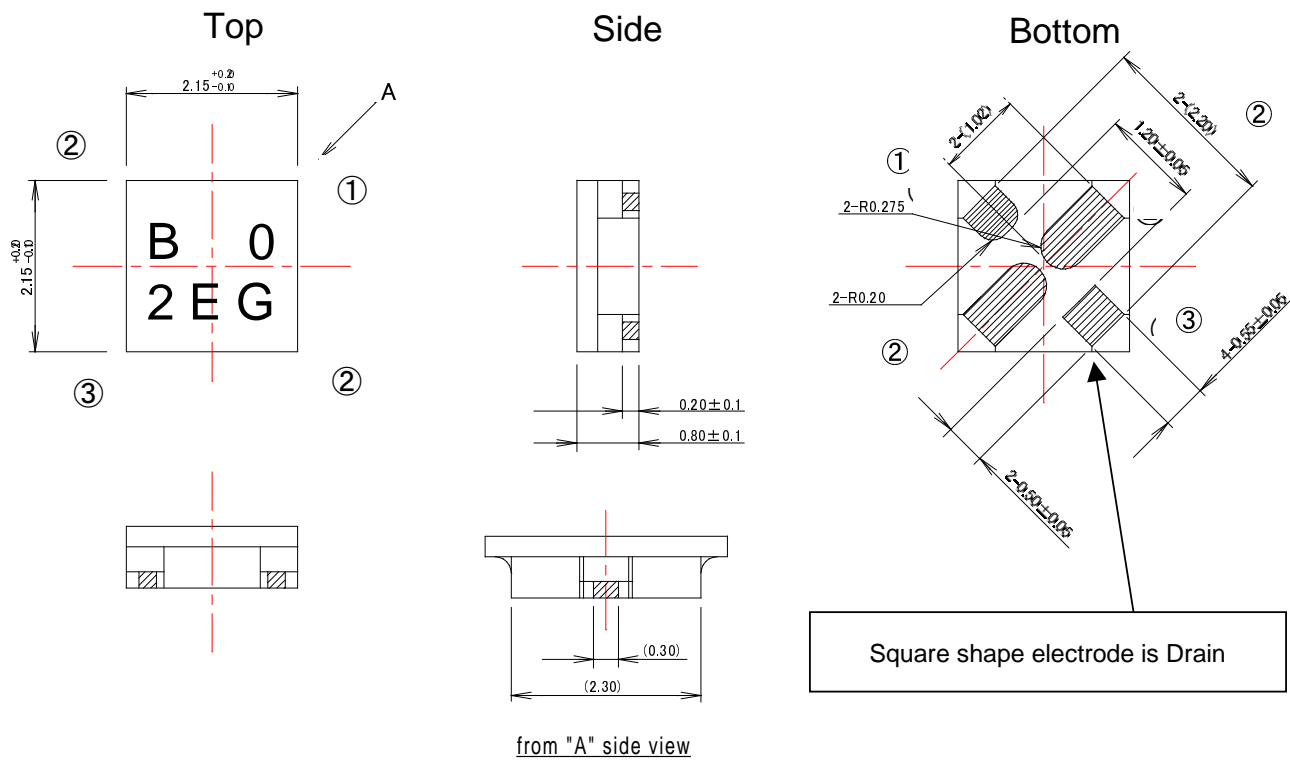

- ① Gate
- ② Source
- ③ Drain

TYPICAL CHARACTERISTICS (Ta=25°C)

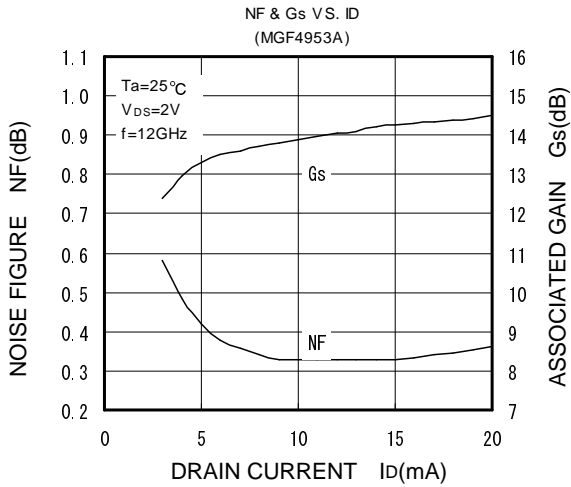
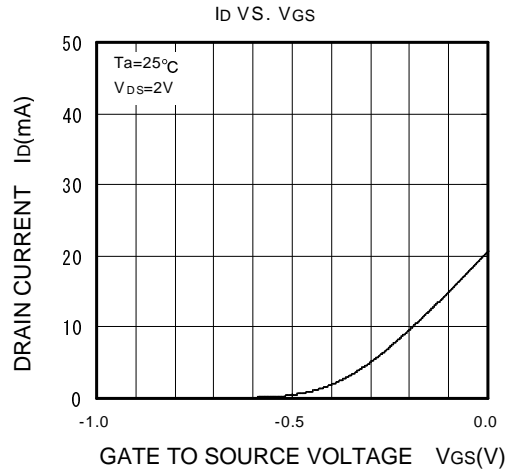
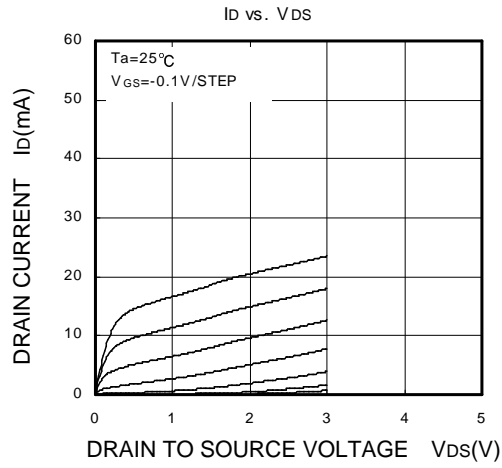

S PARAMETERS

(Ta=25°C, VDS=2V, ID=10mA)

Freq (GHz)	S11		S21		S12		S22	
	(mag)	(ang)	(mag)	(ang)	(mag)	(ang)	(mag)	(ang)
1	0.911	-12.7	4.924	168.1	0.008	70.3	0.709	-10.7
2	0.894	-29.2	4.806	155.3	0.031	68.8	0.691	-22.7
3	0.875	-40.7	4.796	142.7	0.043	62.2	0.682	-30.1
4	0.858	-53.9	4.672	131.6	0.061	49.4	0.652	-41.7
5	0.830	-66.5	4.524	121.2	0.066	42.9	0.639	-49.6
6	0.797	-77.7	4.308	109.5	0.073	33.5	0.631	-58.5
7	0.770	-87.0	4.114	101.1	0.080	26.2	0.628	-64.4
8	0.751	-94.2	3.984	90.8	0.089	22.1	0.625	-71.0
9	0.727	-103.0	3.886	81.4	0.090	17.4	0.624	-76.1
10	0.713	-110.8	3.881	75.0	0.101	9.2	0.628	-80.4
11	0.686	-119.9	3.886	66.0	0.110	2.2	0.612	-87.5
12	0.636	-132.8	3.937	54.7	0.120	-4.6	0.581	-94.3
13	0.590	-146.6	4.078	45.0	0.127	-13.0	0.540	-101.0
14	0.538	-165.8	4.163	31.5	0.136	-25.2	0.485	-112.5
15	0.507	170.2	4.239	18.9	0.144	-35.8	0.396	-122.4
16	0.506	140.8	4.238	4.5	0.151	-48.2	0.283	-137.3
17	0.552	110.4	4.067	-10.5	0.151	-62.0	0.159	-162.3
18	0.625	86.0	3.791	-26.5	0.145	-74.0	0.076	120.8
19	0.696	65.9	3.428	-40.5	0.137	-85.8	0.164	54.1
20	0.745	50.8	3.045	-54.3	0.118	-97.6	0.271	31.6
21	0.791	38.2	2.677	-66.5	0.109	-106.8	0.375	20.9
22	0.794	28.2	2.281	-76.2	0.102	-114.0	0.455	14.3
23	0.776	18.4	1.984	-84.5	0.091	-118.9	0.539	8.5
24	0.802	11.0	1.828	-93.8	0.078	-127.7	0.607	5.7
25	0.796	2.9	1.626	-102.1	0.071	-130.2	0.675	2.1
26	0.799	-8.5	1.424	-114.5	0.064	-138.3	0.730	0.9

NOISE PARAMETERS

(Ta=25°C, VDS=2V, ID=10mA)

f (GHz)	Gamma-opt		Rn (ohm)	NFmin. (dB)	Gs (dB)
	Magn.	Angle			
4	0.64	52.7	0.27	0.22	18.3
8	0.61	103.5	0.15	0.28	15.9
12	0.55	146.4	0.06	0.35	13.5
14	0.51	161.9	0.04	0.39	12.5
18	0.41	175.3	0.03	0.48	11.0
20	0.35	-177.3	0.05	0.55	10.5

Note) Rn is normalized by 50-ohm

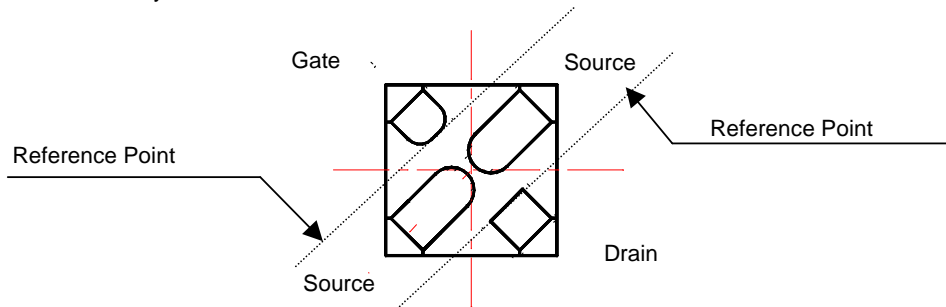

Requests Regarding Safety Designs

Mitsubishi Electric constantly strives to raise the level of its quality and reliability. Despite these concerted efforts, however, there will be occasions when our semiconductor products suffer breakdowns, malfunctions or other problems. In view of this reality, it is requested that every feasible precaution be taken in the pursuit of redundancy design, malfunction prevention design and other safety-related designs, to prevent breakdowns or malfunctions in our products from resulting in accidents involving people, fires, social losses or other problems, thereby upholding the highest levels of safety in the products when in use by customers.

Matters of Importance when Using these Materials

1. These materials are designed as reference materials to ensure that all customers purchase Mitsubishi Electric semiconductors best suited to their specific use applications. Please be aware, however, that the technical information contained in these materials does not comprise consent for the execution or use of intellectual property rights or other rights owned by Mitsubishi Electric Corporation.
2. Mitsubishi Electric does not assume responsibility for damages resulting from the use of product data, graphs, charts, programs, algorithms or other applied circuit examples described in these materials, or for the infringement of the rights of third-party owners resulting from such use.
3. The data, graphs, charts, programs, algorithms and all other information described in these materials were current at the issue of these materials, with Mitsubishi Electric reserving the right to make any necessary updates or changes in the products or specifications in these materials without prior notice. Before purchasing Mitsubishi Electric semiconductor products, therefore, please obtain the latest available information from Mitsubishi Electric directly or an authorized dealer.
4. Every possible effort has been made to ensure that the information described in these materials is fully accurate. However, Mitsubishi Electric assumes no responsibility for damages resulting from inaccuracies occurring within these materials.
5. When using the product data, technical contents indicated on the graphs, charts, programs or algorithms described in these materials, assessments should not be limited to only the technical contents, programs and algorithm units. Rather, it is requested that ample evaluations be made of each individual system as a whole, with the customer assuming full responsibility for decisions on the propriety of application. Mitsubishi Electric does not accept responsibility for the propriety of application.
6. The products described in these materials, with the exception of special mention concerning use and reliability, have been designed and manufactured with the purpose of use in general electronic machinery. Accordingly these products have not been designed and manufactured with the purpose of application in machinery or systems that will be used under conditions that can affect human life, or in machinery or systems used in social infrastructure that demand a particularly high degree of reliability. When considering the use of the products described in these materials in transportation machinery (automobiles, trains, vessels), for objectives related to medical treatment, aerospace, nuclear power control, submarine repeaters or systems or other specialized applications, please consult with Mitsubishi Electric directly or an authorized dealer.
7. When considering use of products for purposes other than the specific applications described in these materials, please inquire at Mitsubishi Electric or an authorized dealer.
8. The prior consent of Mitsubishi Electric in writing is required for any reprinting or reproduction of these materials.
9. Please direct any inquiries regarding further details of these materials, or any other comments or matters of attention, to Mitsubishi Electric or an authorized dealer.