

Chip Inductor for Automotive (Chip Coil for Automotive) Power Inductor (Wire Wound Type for Choke)

LQH32C_53 Series (1210 Size)

■ Dimensions

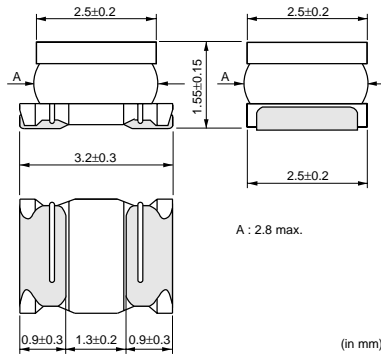

■ Packaging

Code	Packaging	Minimum Quantity
L	180mm Embossed Tape	2000
K	330mm Embossed Tape	7500
B	Bulk(Bag)	500

■ Rated Value (□: packaging code)

Part Number	Inductance	Test Frequency	Rated Current	DC Resistance	Self Resonance Frequency (min.)	Class of Magnetic Shield
LQH32CH1R0M53□	1.0 μ H \pm 20%	1MHz	1000mA	0.06ohm \pm 30%	100MHz	No magnetic shield
LQH32CH2R2M53□	2.2 μ H \pm 20%	1MHz	790mA	0.097ohm \pm 30%	64MHz	No magnetic shield
LQH32CH3R3M53□	3.3 μ H \pm 20%	1MHz	710mA	0.12ohm \pm 30%	50MHz	No magnetic shield
LQH32CH4R7M53□	4.7 μ H \pm 20%	1MHz	650mA	0.15ohm \pm 30%	43MHz	No magnetic shield
LQH32CH6R8M53□	6.8 μ H \pm 20%	1MHz	540mA	0.25ohm \pm 30%	32MHz	No magnetic shield
LQH32CH100K53□	10 μ H \pm 10%	1MHz	450mA	0.30ohm \pm 30%	26MHz	No magnetic shield
LQH32CH150K53□	15 μ H \pm 10%	1MHz	300mA	0.58ohm \pm 30%	26MHz	No magnetic shield
LQH32CH220K53□	22 μ H \pm 10%	1MHz	250mA	0.71ohm \pm 30%	19MHz	No magnetic shield

Operating Temperature Range: -40 to +85°C

■ Impedance-Frequency Characteristics (Typ.)

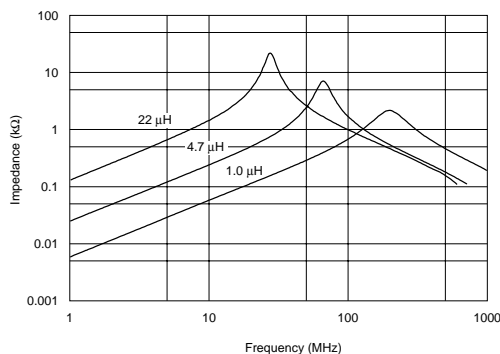

■ Inductance-Current Characteristics (Typ.)

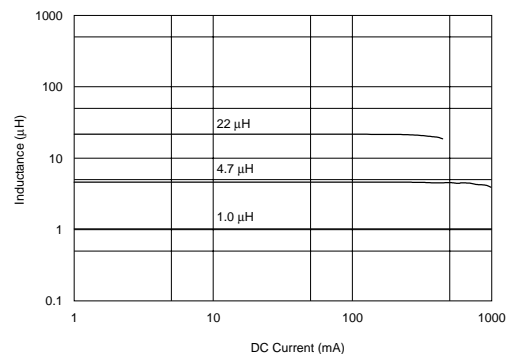

Continued on the following page.

● This data sheet is applied for CHIP INDUCTORS (CHIP COILS) used for Automotive Electronics equipment for your design.

⚠ Note:

1. This datasheet is downloaded from the website of Murata Manufacturing Co., Ltd. Therefore, its specifications are subject to change or our products in it may be discontinued without advance notice. Please check with our sales representatives or product engineers before ordering.
2. This datasheet has only typical specifications because there is no space for detailed specifications. Therefore, please approve our product specifications or transact the approval sheet for product specifications before ordering.

 Continued from the preceding page.

■ Caution/Notice

Caution (Rating)

Do not use products beyond the rated current as this may create excessive heat.

Notice

Solderability of Tin plating termination chip might be deteriorated when low temperature soldering profile where peak solder temperature is below the Tin melting point is used. Please confirm the solderability of Tin plating termination chip before use.

● This data sheet is applied for CHIP INDUCTORS (CHIP COILS) used for Automotive Electronics equipment for your design.

Note:

1. This datasheet is downloaded from the website of Murata Manufacturing co., Ltd. Therefore, it's specifications are subject to change or our products in it may be discontinued without advance notice. Please check with our sales representatives or product engineers before ordering.
2. This datasheet has only typical specifications because there is no space for detailed specifications. Therefore, please approve our product specifications or transact the approval sheet for product specifications before ordering.