



MIC6315

Open-Drain μ P Reset Circuit

General Description

The MIC6315 is an inexpensive reset generator circuit that monitors power supplies in microprocessor based systems.

The function of this device is to assert a reset if either the power supply drops below a designated reset threshold level or /MR is forced low. Several different reset threshold levels are available to accommodate 3V, 3.3V or 5V powered systems.

The MIC6315 has an active low, open-drain /RESET output. The reset output is guaranteed to remain asserted for a minimum of either 20ms, 140ms, or 1100ms after V_{CC} has risen above the designed reset threshold level. The MIC6315 comes in a 4-pin SOT-143 package.

Features

- Precision voltage monitor for 3V, 3.3V or 5V power supplies
- /RESET remains valid with V_{CC} as low as 1V
- 5 μ A supply current
- 20ms, 140ms, or 1100ms minimum reset pulse widths available
- Manual reset input
- 4-pin SOT-143 package

Applications

- Portable equipment
- Intelligent instruments
- Critical microprocessor power monitoring
- Printers/computers
- Embedded controllers

Typical Application

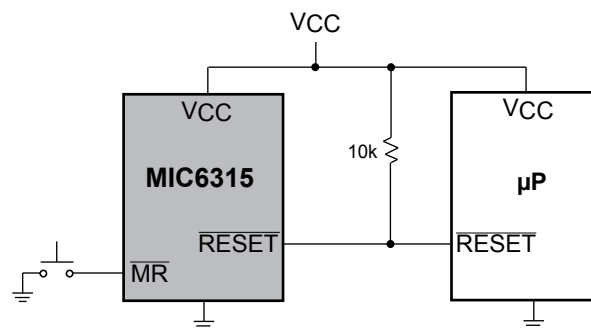

Ordering Information^(1, 2)

Standard		Pb-Free		Nominal V _{TH} (V)	Min. t _{RST} (ms)	Operating Temp. Range	Package
Part Number	Marking	Part Number	Marking				
MIC6315-26D2U	NY	MIC6315-26D2UY	<u>NY</u>	2.63	20	-40°C to +85°C	4-lead SOT-143
MIC6315-29D2U	NM	MIC6315-29D2UY	<u>NM</u>	2.93	20	-40°C to +85°C	4-lead SOT-143
MIC6315-30D2U	N2	MIC6315-30D2UY	<u>N2</u>	3.00	20	-40°C to +85°C	4-lead SOT-143
MIC6315-31D2U	NF	MIC6315-31D2UY	<u>NF</u>	3.08	20	-40°C to +85°C	4-lead SOT-143
MIC6315-40D2U	NW	MIC6315-40D2UY	<u>NW</u>	4.00	20	-40°C to +85°C	4-lead SOT-143
MIC6315-41D2U	N6	MIC6315-41D2UY	<u>N6</u>	4.10	20	-40°C to +85°C	4-lead SOT-143
MIC6315-44D2U	NG	MIC6315-44D2UY	<u>NG</u>	4.38	20	-40°C to +85°C	4-lead SOT-143
MIC6315-46D2U	NQ	MIC6315-46D2UY	<u>NQ</u>	4.63	20	-40°C to +85°C	4-lead SOT-143
MIC6315-26D3U	NR	MIC6315-26D3UY	<u>NR</u>	2.63	140	-40°C to +85°C	4-lead SOT-143
MIC6315-29D3U	NP	MIC6315-29D3UY	<u>NP</u>	2.93	140	-40°C to +85°C	4-lead SOT-143
MIC6315-30D3U	N3	MIC6315-30D3UY	<u>N3</u>	3.00	140	-40°C to +85°C	4-lead SOT-143
MIC6315-31D3U	NU	MIC6315-31D3UY	<u>NU</u>	3.08	140	-40°C to +85°C	4-lead SOT-143
MIC6315-40D3U	N8	MIC6315-40D3UY	<u>N8</u>	4.00	140	-40°C to +85°C	4-lead SOT-143
MIC6315-41D3U	N5	MIC6315-41D3UY	<u>N5</u>	4.10	140	-40°C to +85°C	4-lead SOT-143
MIC6315-42D3U	ON	MIC6315-42D3UY	<u>ON</u>	4.20	140	-40°C to +85°C	4-lead SOT-143
MIC6315-44D3U	NH	MIC6315-44D3UY	<u>NH</u>	4.38	140	-40°C to +85°C	4-lead SOT-143
MIC6315-46D3U	NX	MIC6315-46D3UY	<u>NX</u>	4.63	140	-40°C to +85°C	4-lead SOT-143
MIC6315-26D4U	NS	MIC6315-26D4UY	<u>NS</u>	2.63	1100	-40°C to +85°C	4-lead SOT-143
MIC6315-29D4U	NN	MIC6315-29D4UY	<u>NN</u>	2.93	1100	-40°C to +85°C	4-lead SOT-143
MIC6315-30D4U	N4	MIC6315-30D4UY	<u>N4</u>	3.00	1100	-40°C to +85°C	4-lead SOT-143
MIC6315-31D4U	2N	MIC6315-31D4UY	<u>2N</u>	3.08	1100	-40°C to +85°C	4-lead SOT-143
MIC6315-40D4U	M9	MIC6315-40D4UY	<u>M9</u>	4.00	1100	-40°C to +85°C	4-lead SOT-143
MIC6315-41D4U	M7	MIC6315-41D4UY	<u>M7</u>	4.10	1100	-40°C to +85°C	4-lead SOT-143
MIC6315-44D4U	NJ	MIC6315-44D4UY	<u>NJ</u>	4.38	1100	-40°C to +85°C	4-lead SOT-143
MIC6315-46D4U	NZ	MIC6315-46D4UY	<u>NZ</u>	4.63	1100	-40°C to +85°C	4-lead SOT-143

Notes:

1. All devices available in tape and reel only.
2. Parts not yet assigned an identification code are shown as "zz". Contact Micrel for details. Minimum order may apply.

Pin Configuration

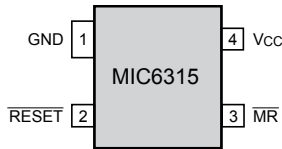

MIC6315-xxDyU 4-Lead SOT-143

Pin Description

Pin Number	Pin Name	Pin Function
1	GND	IC Ground Pin.
2	/RESET	/RESET goes low if V _{CC} falls below the reset threshold and remains asserted for one reset timeout period after V _{CC} exceeds the reset threshold.
3	/MR	Manual Reset Input. A logic low on /MR forces a reset. The reset will remain asserted as long as /MR is held low and for one reset timeout period after /MR goes high. This input can be shorted to ground via a switch or be driven by TTL or CMOS logic. Float if unused.
4	VCC	Power Supply Input.

Absolute Maximum Ratings⁽¹⁾

Terminal Voltage (V_{CC} , /RESET).....	-0.3V to 6.0V
(/MR).....	-0.3V to ($V_{CC} + 0.3V$)
Rate of Rise (V_{CC}).....	100V/ μ s
Input Current (V_{CC} , /MR).....	20mA
Output Current (/RESET).....	20mA
Lead Temperature (soldering, 10 sec.).....	300°C
Storage Temperature (T_S).....	-65°C to 150°C
ESD Rating ⁽³⁾	3kV

Operating Ratings⁽²⁾

Operating Temperature Range.....	-40°C to +85°C
Input Voltage (/RESET).....	GND – 5.5V
Power Dissipation ($T_A = +70^\circ\text{C}$).....	320mW

Electrical Characteristics

For typical values, $V_{CC} = 2.5V$ to $5.5V$, $T_A = 25^\circ\text{C}$; **bold** values indicate $-40^\circ\text{C} \leq T_A \leq +85^\circ\text{C}$; unless noted

Symbol	Parameter	Condition	Min	Typ	Max	Units
V_{CC}	Operating Voltage Range		1		5.5	V
I_{CC}	Supply Current	$V_{CC} = 5.5V$, no load		5	15	μ A
		$V_{CC} = 3.6V$, no load		5	10	μ A
V_{TH}	Reset Voltage Threshold	Note 4	$V_{TH}-2.5\%$	V_{TH}	$V_{TH}+2.5\%$	V
t_{RST}	Reset Timeout Period	D2U	20	28	44	ms
		D3U	140	200	320	ms
		D4U	1100	1500	2500	ms
V_{OL}	/RESET Output Voltage	$V_{CC} \geq 4.0V$, $I_{SINK} = 3.2mA$			0.4	V
		$V_{CC} > 2.5V$, $I_{SINK} = 1.2mA$			0.3	V
		$V_{CC} \geq 1.0V$, $I_{SINK} = 50\mu A$			0.3	V
	/RESET Output Leakage	/RESET deasserted			1	μ A
	/MR Minimum Pulse Width		10			μ s
	/MR to Reset Delay			0.5		μ s
V_{IH}	/MR Input Threshold	$V_{TH} > 4.0V$	2.3			V
		$V_{TH} < 4.0V$	$0.7 \times V_{CC}$			V
V_{IL}	/MR Input Threshold	$V_{TH} > 4.0V$			0.8	V
		$V_{TH} < 4.0V$			$0.25 \times V_{CC}$	V
	/MR Pull-Up Resistance		10	20	30	k Ω
	/MR Glitch Immunity			100		ns

Notes:

1. Exceeding the absolute maximum rating may damage the device.
2. The device is not guaranteed to function outside its operating rating.
3. Devices are ESD sensitive. Handling precautions recommended. Human body model, 1.5k in series with 100pF.
4. Various reset thresholds available. See ordering information or contact factory.

Timing Diagram

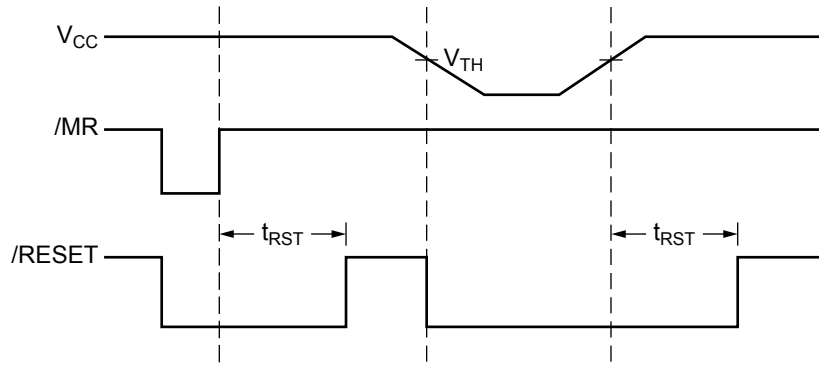

Reset Timing Diagram

Functional Diagram

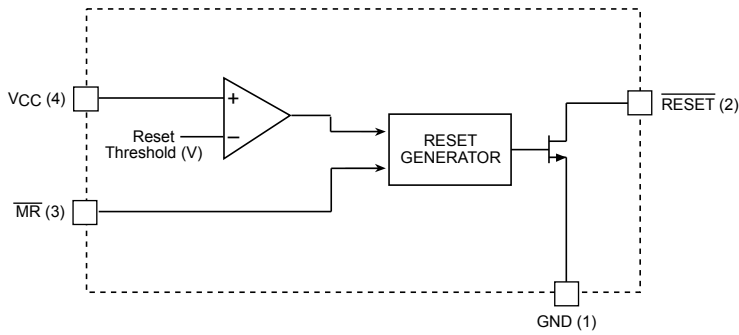

Applications Information

Microprocessor Reset

The /RESET pin is asserted whenever V_{CC} falls below the reset threshold voltage or if /MR (manual reset) is forced low. The /RESET pin remains asserted for the duration of the reset timeout period after V_{CC} has risen above the reset threshold or /MR has returned high. The reset function ensure the microprocessor is properly reset and powers up in a known condition after a power failure. /RESET will remain valid with V_{CC} as low as 1V.

The /RESET output is a simple open-drain N-channel MOSFET structure. A pull-up resistor must be used to pull this output up to some voltage. For most applications, this voltage will be the same power supply that supplies V_{CC} to the MIC6315. It is possible, however, to tie this resistor to some other voltage. This will allow the MIC6315 to monitor one voltage while level-shifting the /RESET output to some other voltage. The pull-up voltage must be limited to 6.0V or less (absolute maximum) to avoid damage to the MIC6315. The resistor must be small enough to supply current to the inputs and leakage paths that are driven by the /RESET output.

/RESET Valid at Low Voltage

As V_{CC} drops to 0V, the MIC6315 will no longer be able to pull the /RESET output low. At this point, the pull-up resistor will pull the output high. The value of the pull-up resistor and the voltage it is connected to will affect the point at which this happens.

Wire OR'ing The /RESET Output

Because the RESET output is open-drain, several reset sources can be wire-ORed, in parallel, to allow resets from multiple sources.

V_{CC} Transients

The MIC6315 is relatively immune to negative-going V_{CC} glitches below the reset threshold. Typically, a negative-going transient 125mV below the reset threshold with a duration of 20 μ s or less will not cause an unwanted reset. If additional transient immunity is needed, a bypass capacitor can be placed a close as possible to the MIC6315.

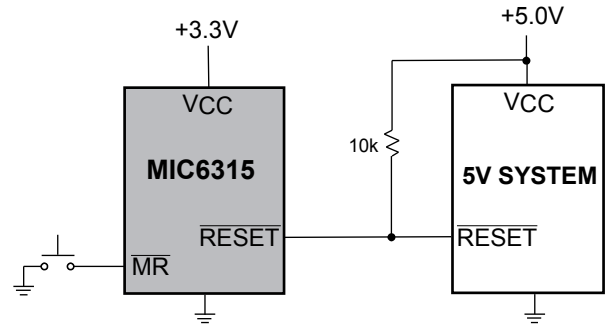

MIC6315 Used in a Multiple Supply System

Package Information

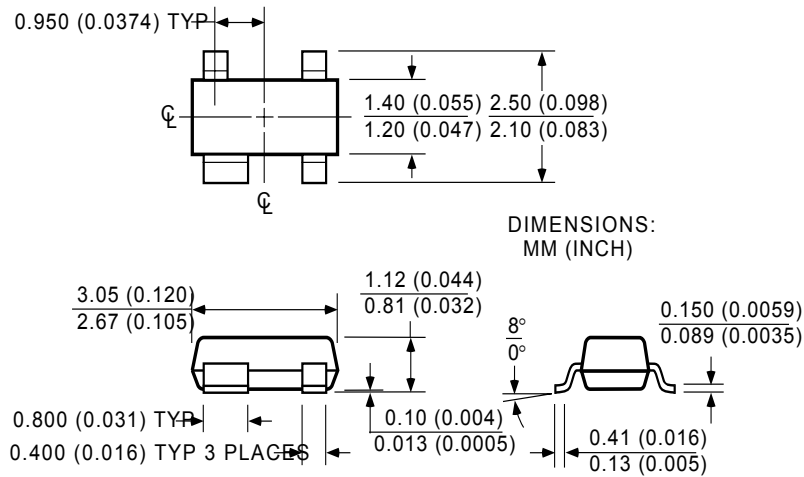

4-Pin SOT-143 (U)

MICREL, INC. 2180 FORTUNE DRIVE SAN JOSE, CA 95131 USA

TEL + 1 (408) 944-0800 FAX + 1 (408) 474-1000 WEB <http://www.micrel.com>

The information furnished by Micrel in this datasheet is believed to be accurate and reliable. However, no responsibility is assumed by Micrel for its use. Micrel reserves the right to change circuitry and specifications at any time without notification to the customer.

Micrel Products are not designed or authorized for use as components in life support appliances, devices or systems where malfunction of a product can reasonably be expected to result in personal injury. Life support devices or systems are devices or systems that (a) are intended for surgical implant into the body or (b) support or sustain life, and whose failure to perform can be reasonably expected to result in a significant injury to the user. A Purchaser's use or sale of Micrel Products for use in life support appliances, devices or systems is at Purchaser's own risk and Purchaser agrees to fully indemnify

Micrel for any damages resulting from such use or sale.

© 2005 Micrel, Incorporated.