



## N-Channel Enhancement Mode Field Effect Transistor

| PRODUCT SUMMARY  |                |                              |
|------------------|----------------|------------------------------|
| V <sub>DSS</sub> | I <sub>D</sub> | R <sub>DS(ON)</sub> (mΩ) Max |
| 40V              | 10A            | 35@ V <sub>GS</sub> = 10V    |
|                  |                | 60@ V <sub>GS</sub> = 4.5V   |

### FEATURES

- Super high dense cell design for low R<sub>DS(ON)</sub>.
- Rugged and reliable.
- TO-252 and TO-251 Package.

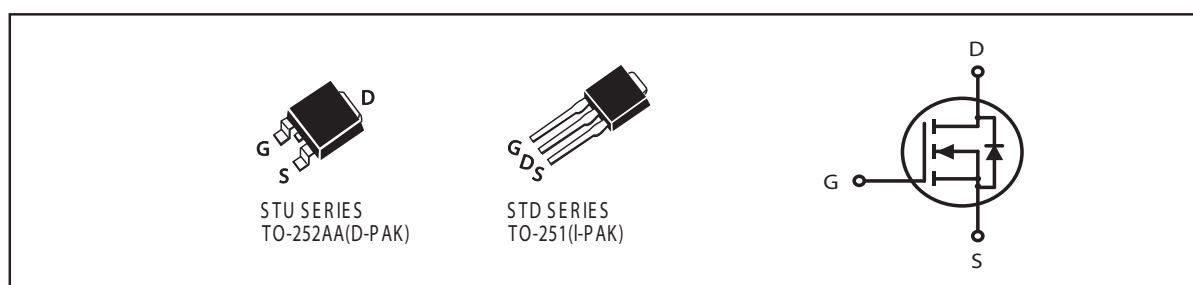

### ABSOLUTE MAXIMUM RATINGS (T<sub>A</sub>=25°C unless otherwise noted)

| Parameter  | Symbol                            | Limit                 | Unit |   |
|--|-----------------------------------|-----------------------|------|---|
| Drain-Source Voltage                                   | V <sub>DS</sub>                   | 40                    | V    |   |
| Gate-Source Voltage                                    | V <sub>GS</sub>                   | ±20                   | V    |   |
| Drain Current-Continuous <sup>a</sup> @ T <sub>a</sub> | I <sub>D</sub>                    | 25°C                  | 10   | A |
|  |                                   | 70°C                  | 8.3  | A |
| -Pulsed <sup>b</sup>                                   | I <sub>DM</sub>                   | 40                    | A    |   |
| Drain-Source Diode Forward Current <sup>a</sup>        | I <sub>S</sub>                    | 15                    | A    |   |
| Maximum Power Dissipation <sup>a</sup>                 | P <sub>D</sub>                    | T <sub>a</sub> = 25°C | 50   | W |
|  |                                   | T <sub>a</sub> =70°C  | 35   |   |
| Operating Junction and Storage Temperature Range       | T <sub>J</sub> , T <sub>STG</sub> | -55 to 175            | °C   |   |

### THERMAL CHARACTERISTICS

|   |                  |    |      |
|---|------------------|----|------|
| Thermal Resistance, Junction-to-Case    | R <sub>θJC</sub> | 3  | °C/W |
| Thermal Resistance, Junction-to-Ambient | R <sub>θJA</sub> | 50 | °C/W |

# STU/D2240NL

N-Channel ELECTRICAL CHARACTERISTICS (T<sub>A</sub> = 25 °C unless otherwise noted)

| Parameter                              | Symbol              | Condition   | Min | Typ <sup>c</sup> | Max  | Unit  |
|--|---------------------|---|-----|------------------|------|-------|
| OFF CHARACTERISTICS                    |                     |   |     |                  |      |       |
| Drain-Source Breakdown Voltage         | BV <sub>DSS</sub>   | V <sub>GS</sub> = 0V, I <sub>D</sub> = 250uA  | 40  |                  |      | V     |
| Zero Gate Voltage Drain Current        | I <sub>DSS</sub>    | V <sub>DS</sub> = 32V, V <sub>GS</sub> = 0V   |     |                  | 1    | uA    |
| Gate-Body Leakage                      | I <sub>GSS</sub>    | V <sub>GS</sub> = ±20V, V <sub>DS</sub> = 0V  |     |                  | ±100 | nA    |
| ON CHARACTERISTICS <sup>b</sup>        |                     |   |     |                  |      |       |
| Gate Threshold Voltage                 | V <sub>GS(th)</sub> | V <sub>DS</sub> = V <sub>GS</sub> , I <sub>D</sub> = 250uA  | 1.0 | 1.8              | 3.0  | V     |
| Drain-Source On-State Resistance       | R <sub>DS(ON)</sub> | V <sub>GS</sub> = 10V, I <sub>D</sub> = 10A   |     | 25               | 35   | m ohm |
|  |                     | V <sub>GS</sub> = 4.5V, I <sub>D</sub> = 8A   |     | 45               | 60   | m ohm |
| On-State Drain Current                 | I <sub>D(ON)</sub>  | V <sub>DS</sub> = 5V, V <sub>GS</sub> = 10V   | 20  |                  |      | A     |
| Forward Transconductance               | g <sub>FS</sub>     | V <sub>DS</sub> = 10V, I <sub>D</sub> = 10A   |     | 12               |      | S     |
| DYNAMIC CHARACTERISTICS <sup>c</sup>   |                     |   |     |                  |      |       |
| Input Capacitance                      | C <sub>ISS</sub>    | V <sub>DS</sub> = 25V, V <sub>GS</sub> = 0V<br>f = 1.0MHz   |     | 840              | 950  | pF    |
| Output Capacitance                     | C <sub>OSS</sub>    |   |     | 85               | 98   | pF    |
| Reverse Transfer Capacitance           | C <sub>RSS</sub>    |   |     | 70               | 82   | pF    |
| Gate resistance                        | R <sub>g</sub>      | V <sub>GS</sub> = 0V, V <sub>DS</sub> = 0V, f = 1.0MHz  |     | 2.5              |      | ohm   |
| SWITCHING CHARACTERISTICS <sup>c</sup> |                     |   |     |                  |      |       |
| Turn-On Delay Time                     | t <sub>D(ON)</sub>  | V <sub>DD</sub> = 20V<br>I <sub>D</sub> = 1 A<br>V <sub>GS</sub> = 4.5V<br>R <sub>GEN</sub> = 3.3 ohm |     | 15.2             | 18   | ns    |
| Rise Time                              | t <sub>r</sub>      |   |     | 4.8              | 5.6  | ns    |
| Turn-Off Delay Time                    | t <sub>D(OFF)</sub> |   |     | 18.6             | 22   | ns    |
| Fall Time                              | t <sub>f</sub>      |   |     | 12.1             | 14   | ns    |
| Total Gate Charge                      | Q <sub>g</sub>      | V <sub>DS</sub> = 20V, I <sub>D</sub> = 10A, V <sub>GS</sub> = 10V                                    |     | 18.7             | 22   | nC    |
|  |                     | V <sub>DS</sub> = 20V, I <sub>D</sub> = 10A, V <sub>GS</sub> = 4.5V                                   |     | 8.9              | 10   | nC    |
| Gate-Source Charge                     | Q <sub>gs</sub>     | V <sub>DS</sub> = 20V, I <sub>D</sub> = 10A   |     | 3.9              | 4.6  | nC    |
| Gate-Drain Charge                      | Q <sub>gd</sub>     | V <sub>GS</sub> = 10V   |     | 3.1              | 3.6  | nC    |

# STU/D2240NL

## ELECTRICAL CHARACTERISTICS ( $T_c=25^\circ\text{C}$ unless otherwise noted)

| Parameter  | Symbol   | Condition                | Min | Typ | Max | Unit |
|--|----------|--------------------------|-----|-----|-----|------|
| <b>DRAIN-SOURCE DIODE CHARACTERISTICS <sup>a</sup></b> |          |                          |     |     |     |      |
| Diode Forward Voltage                                  | $V_{SD}$ | $V_{GS} = 0V, I_s = 15A$ |     | 1   | 1.3 | V    |

### Notes

- a. Pulse Test: Pulse Width  $\leq 300\mu\text{s}$ , Duty Cycle  $\leq 2\%$ .
- b. Guaranteed by design, not subject to production testing.

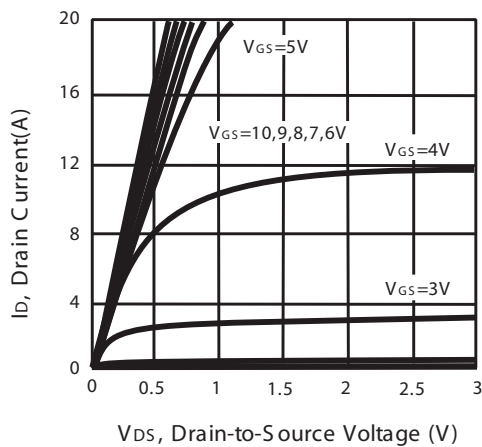

Figure 1. Output Characteristics

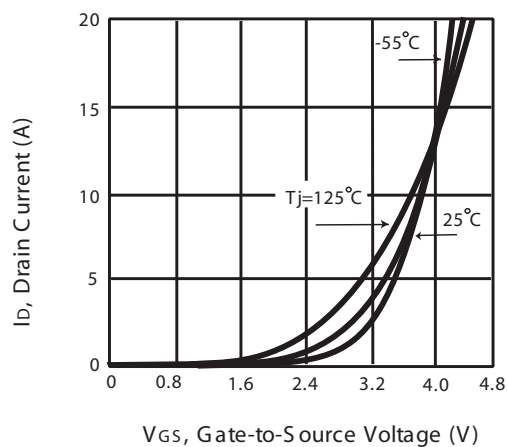

Figure 2. Transfer Characteristics

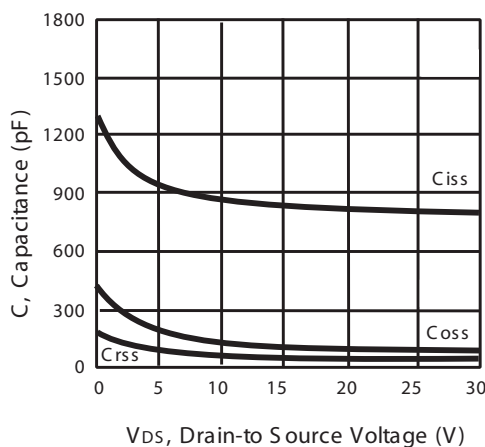

Figure 3. Capacitance

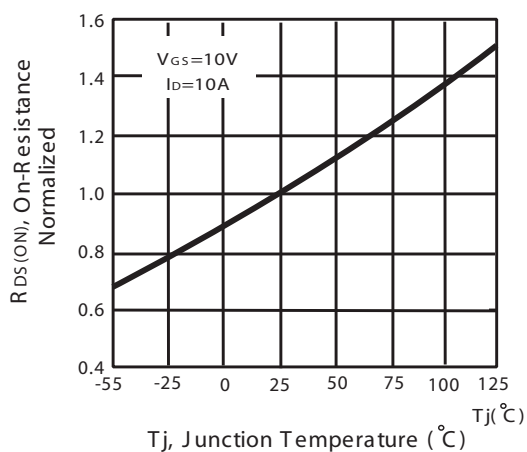

Figure 4. On-Resistance Variation with Drain Current and Temperature

# STU/D2240NL

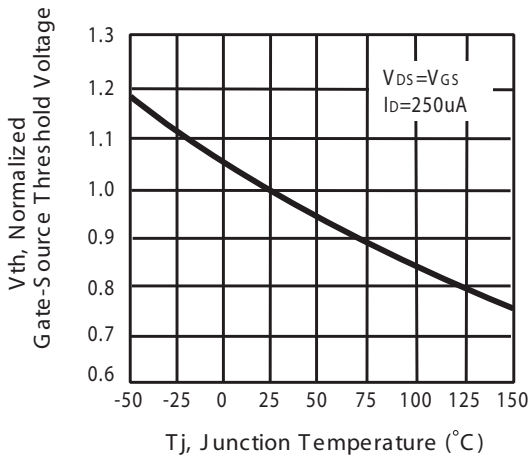

Figure 5. Gate Threshold Variation with Temperature

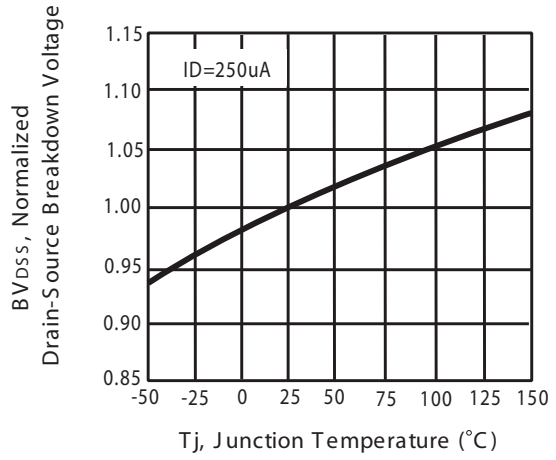

Figure 6. Breakdown Voltage Variation with Temperature

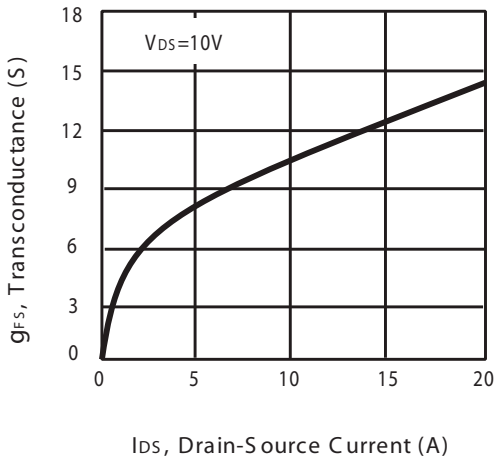

Figure 7. Transconductance Variation with Drain Current

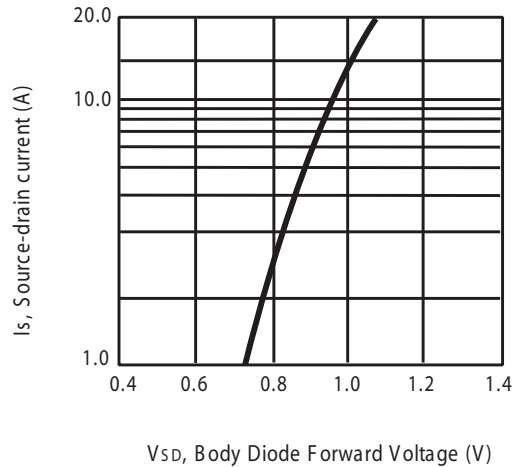

Figure 8. Body Diode Forward Voltage Variation with Source Current

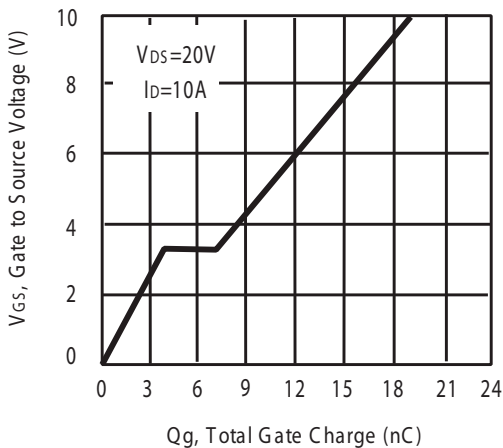

Figure 9. Gate Charge

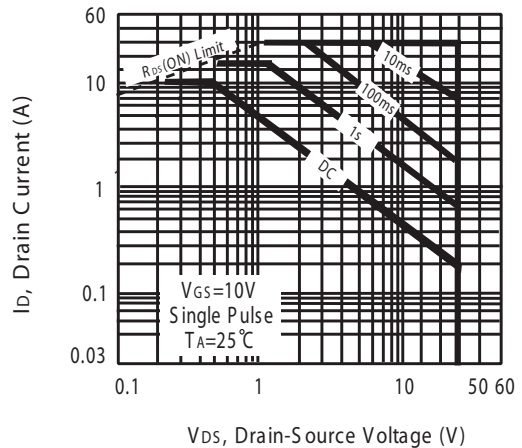

Figure 10. Maximum Safe Operating Area

# STU/D2240NL

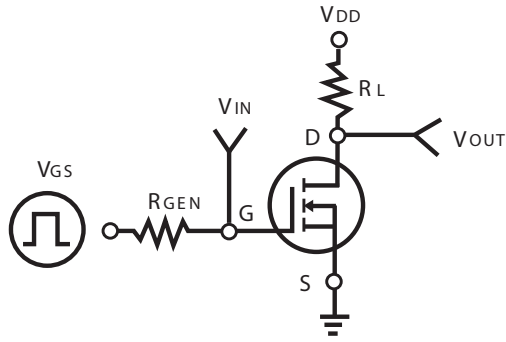

Figure 11. Switching Test Circuit

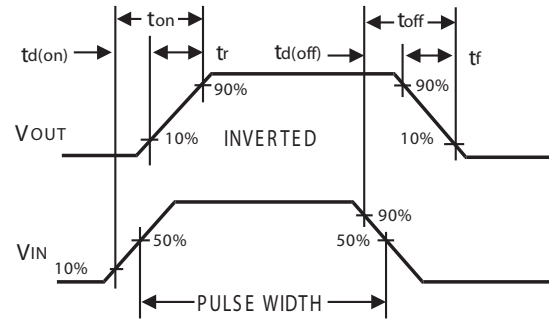
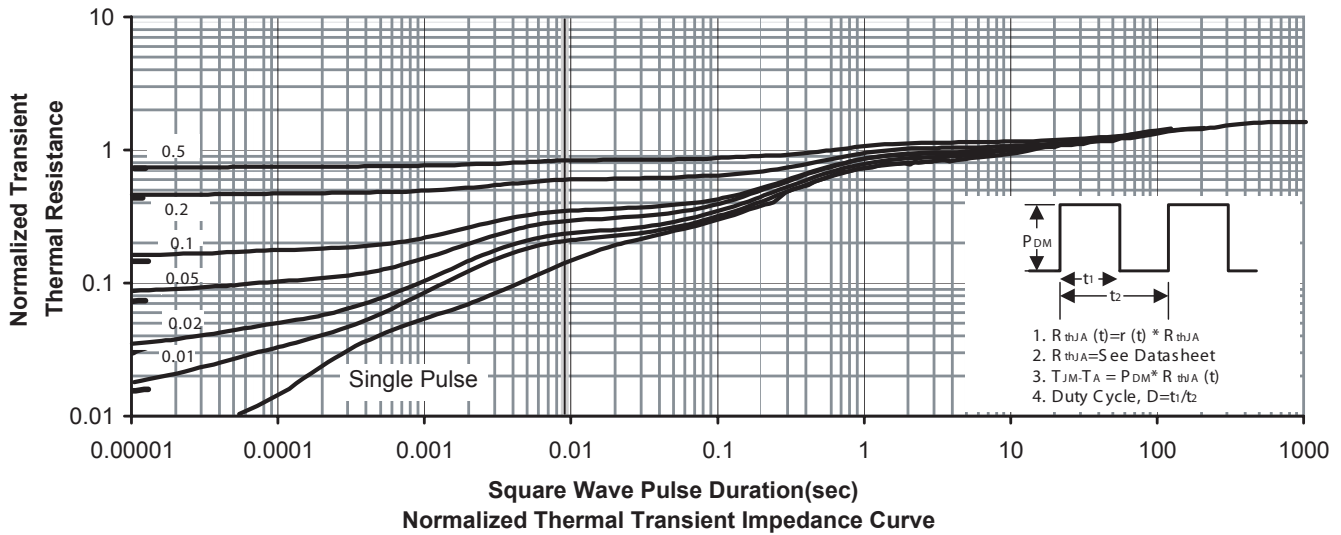

Figure 12. S switching Waveforms



# STU/D2240NL

## PACKAGE OUTLINE DIMENSIONS

### TO-251

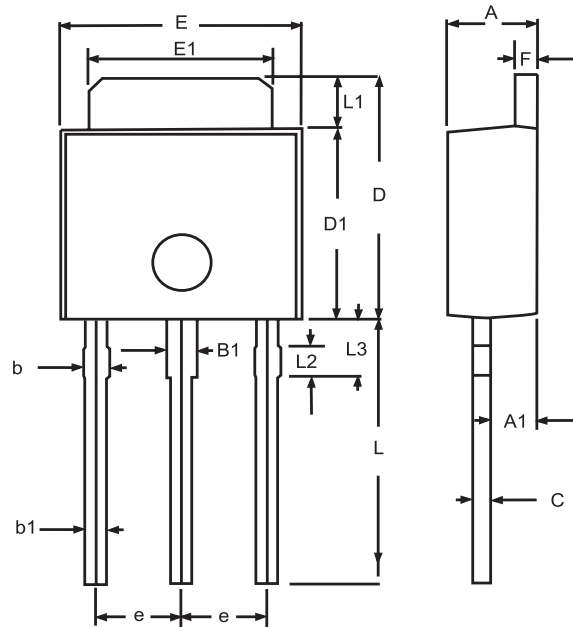

| SYMBOLS | MILLIMETERS |       | INCHES |       |
|---------|-------------|-------|--------|-------|
|         | MIN         | MAX   | MIN    | MAX   |
| A       | 2.20        | 2.40  | 0.087  | 0.095 |
| A1      | 1.100       | 1.300 | 0.043  | 0.051 |
| B1      | 0.650       | 1.050 | 0.026  | 0.041 |
| b       | 0.500       | 0.900 | 0.020  | 0.035 |
| b1      | 0.400       | 0.800 | 0.016  | 0.32  |
| C       | 0.400       | 0.600 | 0.016  | 0.024 |
| D       | 6.700       | 7.300 | 0.264  | 0.287 |
| D1      | 5.400       | 5.650 | 0.213  | 0.222 |
| E       | 6.40        | 6.650 | 0.252  | 0.262 |
| e       | 2.100       | 2.500 | 0.083  | 0.098 |
| F       | 0.400       | 0.600 | 0.016  | 0.024 |
| L       | 7.000       | 8.000 | 0.276  | 0.315 |
| L1      | 1.300       | 1.700 | 0.051  | 0.067 |
| L2      | 0.700       | 0.900 | 0.028  | 0.035 |
| L3      | 1.400       | 1.800 | 0.055  | 0.071 |

# STU/D2240NL

## PACKAGE OUTLINE DIMENSIONS

### TO-252

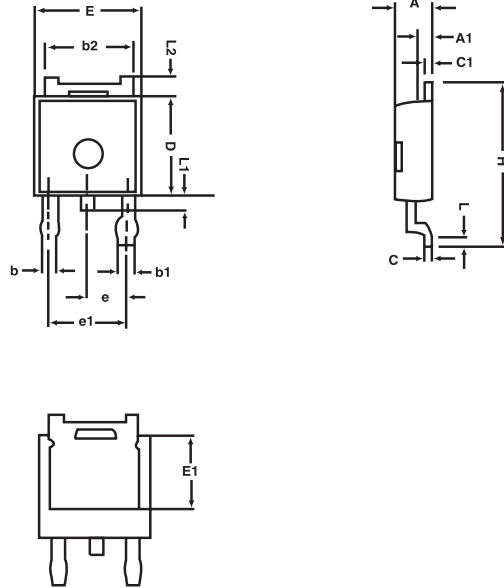

| SYMBOLS | MILLIMETERS |       | INCHES |       |
|---------|-------------|-------|--------|-------|
|         | MIN         | MAX   | MIN    | MAX   |
| A       | 2.25        | 2.35  | 0.089  | 0.093 |
| A1      | 0.95        | 1.05  | 0.037  | 0.041 |
| b       | 0.77        | 0.85  | 0.030  | 0.033 |
| b1      | 0.84        | 0.94  | 0.033  | 0.037 |
| b2      | 5.30        | 5.45  | 0.209  | 0.215 |
| C       | 0.49        | 0.53  | 0.019  | 0.021 |
| D       | 6.00        | 6.20  | 0.236  | 0.244 |
| E       | 6.40        | 6.60  | 0.252  | 0.260 |
| E1      | 3.18        | 3.67  | 0.125  | 0.145 |
| e       | 2.29        | BSC   | 0.090  | BSC   |
| H       | 9.70        | 10.10 | 0.382  | 0.398 |
| L       | 1.425       | 1.625 | 0.056  | 0.064 |
| L1      | 0.650       | 0.850 | 0.026  | 0.033 |
| L2      | 0.600       | REF.  | 0.024  | REF.  |

# STU/D2240NL

## TO251 Tube/TO-252 Tape and Reel Data

### TO-251 Tube



### TO-252 Carrier Tape



UNIT:mm

| PACKAGE           | A0           | B0           | K0           | D0  | D1                    | E            | E1           | E2           | P0          | P1          | P2           | T            |
|-------------------|--------------|--------------|--------------|-----|-----------------------|--------------|--------------|--------------|-------------|-------------|--------------|--------------|
| TO-252<br>(16 mm) | 6.80<br>±0.1 | 10.3<br>±0.1 | 2.50<br>±0.1 | φ 2 | φ 1.5<br>+ 0.1<br>- 0 | 16.0<br>0.3± | 1.75<br>0.1± | 7.5<br>±0.15 | 8.0<br>±0.1 | 4.0<br>±0.1 | 2.0<br>±0.15 | 0.3<br>±0.05 |

### TO-252 Reel



UNIT:mm

| TAPE SIZE | REEL SIZE | M              | N             | W                    | T   | H                        | K    | S           | G   | R   | V   |
|-----------|-----------|----------------|---------------|----------------------|-----|--------------------------|------|-------------|-----|-----|-----|
| 16 mm     | φ 330     | φ 330<br>± 0.5 | φ 97<br>± 1.0 | 17.0<br>+ 1.5<br>- 0 | 2.2 | φ 13.0<br>+ 0.5<br>- 0.2 | 10.6 | 2.0<br>±0.5 | --- | --- | --- |