

Datasheet

10 Gbps 850 nm Multi-mode SFP+ Transceiver

SFP-10GD-SX



Features

- Hot-pluggable SFP+ footprint
- Supports 9.95 to 10.52 Gbps bit rates
- Power dissipation < 1W
- RoHS-6 compliant (lead-free)
- Commercial temperature range 0°C to 70°C
- Single 3.3 V power supply
- Maximum link length of 300 m on 2000 MHz-km MMF
- Uncooled 850 nm VCSEL laser
- Receiver limiting electrical interface
- Duplex LC connector
- Built-in digital diagnostic functions

MRV's SFP-10GD-SX 10Gbps SFP+ transceivers are designed for use in 10-Gigabit Ethernet and 10-Gigabit Fibre Channel links over multi-mode fiber. They are compliant with SFF-8431, SFF-8432, and IEEE 802.3ae 10GBASE-SR. Digital Diagnostics functions are available through a 2-wire serial interface, as specified in SFF-8472. The transceiver is RoHS compliant and lead free as defined in Directive 2002/95/EC.

Absolute Maximum Ratings*

Parameter	Symbol	Minimum	Typical	Maximum	Unit	Note
Maximum Supply Voltage	V_{CC}	-0.5	-	4.0	V	-
Case Operating Temperature	T_A	0	-	70	°C	-
Storage Temperature	T_S	-40	-	85	°C	-
Relative Humidity (Non-Condensing)	RH	0	-	85	%	-

*Exceeding the limits listed in the table may damage the transceiver module permanently

Electrical Specifications

Parameter	Symbol	Minimum	Typical	Maximum	Unit	Note
Supply Voltage	V_{CC}	3.14	-	3.46	V	-
Supply Current	I_{CC}	-	-	250	mA	-
Transmitter						
Input Differential Impedance	R_{in}	-	100	-	Ω	1
Single Ended Data Input Swing	$V_{in, pp}$	180	-	700	mV	-
Transmit Disable Voltage	V_D	2	-	V_{CC}	V	-
Transmit Enable Voltage	V_{EN}	V_{EE}	-	$V_{EE}+0.8$	V	-
Receiver						
Single Ended Data Output Swing	$V_{out, pp}$	300	-	850	mV	2
Data Output Rise Time, Fall Time	t_r, t_f	28	-	-	ps	3
LOS Fault	$V_{LOS\ fault}$	2	-	$V_{CC\ HOST}$	V	4
LOS Normal	$V_{LOS\ norm}$	V_{EE}	-	$V_{EE}+0.8$	V	4
Power Supply Noise Tolerance	$V_{CC\ T}/V_{CC\ R}$	Per SFF-8431 Rev 2.1			mVpp	5

- Notes:**
1. Connected directly to TX data input pins. AC coupling from pins into laser driver IC.
 2. Into 100 Ω differential termination.
 3. 20 – 80 % . Measured with Module Compliance Test Board and OMA test pattern. Use of four 1's and four 0's in sequence in the PRBS⁹ is an acceptable alternative. SFF-8431 Rev 2.1
 4. LOS is an open collector output. Should be pulled up with 4.7k Ω – 10k Ω on the host board. Normal operation is logic 0; loss of signal is logic 1. Maximum pull-up voltage is 5.5V.
 5. Testing methodology per SFF-8431. Rev 2.1

Datasheet

Pin Descriptions

Pin	Function	Name/Description	Note
1	V _{EET}	Transmitter Ground (Common with Receiver Ground)	1
2	T _{FAULT}	Transmitter Fault	2
3	T _{DIS}	Transmitter Disable. Laser output disabled on high or open.	3
4	SDA	2-wire Serial Interface Data Line	4
5	SCL	2-wire Serial Interface Clock Line	4
6	MOD_ABS	Module Absent. Grounded within the module.	4
7	RS0	No connection required	
8	RX_LOS	Loss of Signal indication. Logic 0 indicates normal operation.	5
9	RS1	No connection required	
10	V _{EER}	Receiver Ground (Common with Transmitter Ground)	1
11	V _{EER}	Receiver Ground (Common with Transmitter Ground)	1
12	RD-	Receiver Inverted DATA out. AC Coupled.	
13	RD+	Receiver Non-inverted DATA out. AC Coupled.	
14	V _{EER}	Receiver Ground (Common with Transmitter Ground)	1
15	V _{CCR}	Receiver Power Supply	
16	V _{CCT}	Transmitter Power Supply	
17	V _{EET}	Transmitter Ground (Common with Receiver Ground)	1
18	TD+	Transmitter Non-Inverted DATA in. AC Coupled.	
19	TD-	Transmitter Inverted DATA in. AC Coupled.	
20	V _{EET}	Transmitter Ground (Common with Receiver Ground)	1

- Notes:**
1. Circuit ground is internally isolated from chassis ground.
 2. T_{FAULT} is an open collector/drain output, which should be pulled up with a 4.7k – 10k Ohms resistor on the host board if intended for use. Pull up voltage should be between 2.0V to Vcc + 0.3V. A high output indicates a transmitter fault caused by either the TX bias current or the TX output power exceeding the preset alarm thresholds. A low output indicates normal operation. In the low state, the output is pulled to <0.8V.
 3. Laser output disabled on TDIS >2.0V or open, enabled on TDIS <0.8V.
 4. Should be pulled up with 4.7kΩ – 10kΩ on host board to a voltage between 2.0V and 3.6V. MOD_ABS pulls line low to indicate module is plugged in.
 5. LOS is open collector output. Should be pulled up with 4.7kΩ – 10kΩ on host board to a voltage between 2.0V and 3.6V. Logic 0 indicates normal operation; logic 1 indicates loss of signal.

Diagram of Host Board Connector Block Pin Numbers and Names

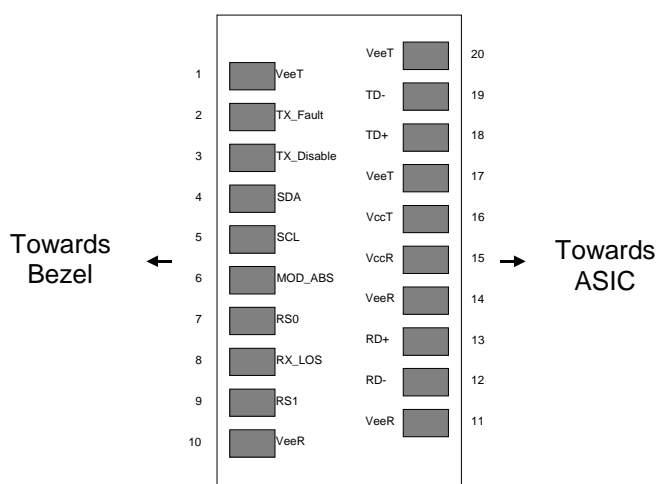

Datasheet
Optical Specifications

Parameter	Symbol	Minimum	Typical	Maximum	Unit	Note
Transmitter						
Optical Modulation Amplitude (OMA)	P_{OMA}	-	-1.5	-	dBm	1
Average Launch Power	P_{AVE}	-5	-	-1	dBm	2
Optical Wavelength	λ	840	850	860	nm	1
RMS Spectral Width	$\Delta\lambda_{rms}$	-	0.4	0.45	dB	1
Optical Extinction Ratio	ER	3.0	5.5	-	dB	-
Transmitter and Dispersion Penalty	TDP	-	-	3.9	dB	-
Average Launch Power of OFF Transmitter	P_{off}	-	-	-30	dBm	-
Tx Jitter	Tx	Per IEEE 802.3ae requirements			mV	-
Encircled Flux	$<4.5\mu m$	-	-	30	%	3
	$<19\mu m$	86	-	-		
Relative Intensity Noise	RIN_{12OMA}	-	-	-128	dB/Hz	-
Receiver						
Receiver Sensitivity (OMA) @ 10.3Gbps	R_{SENS1}	-	-	-11.1	dBm	4
Stressed Receiver Sensitivity (OMA) @ 10.3Gbps	R_{SENS2}	-	-	-7.5	dBm	5
Maximum Input Power	P_{MAX}	+0.5	-	-	dBm	-
Wavelength Range	λ_C	840	-	860	nm	-
Receiver Reflectance	R_{rx}	-	-	-12	dB	-
LOS De-Assert	LOS_D	-	-	-14	dBm	-
LOS Assert	LOS_A	-30	-23	-	dBm	-
LOS Hysteresis	-	0.5	-	-	dB	-

- Notes:
1. See Tradeoff Table 52.8, IEEE 802.3ae 2005
 2. Average Power figures are informative only, from IEEE802.3ae.
 3. Measured into Type A1a (50/125 μm multimode) fiber as described in ANSI/TIA/EIA-455-203-2.
 4. Measured with worst ER; BER $<10^{-12}$; $2^{31} - 1$ PRBS.
 5. See IEEE 802.3ae.

General Specifications

Parameter	Symbol	Minimum	Typical	Maximum	Unit	Note
Bit Rate	BR	9.95	10.3	10.52	Gbps	1
Bit Error Ratio	BER	-	-	10^{-12}	-	2
Maximum Supported Distances						
Fiber Type	850 nm OFL Bandwidth	-	-	-	-	-
62.5 μm	160 MHz-km	Lmax	-	26	m	-
	OM1 200 MHz-km			33		
50 μm	400 MHz-km	Lmax	-	66	m	-
	OM2 200 MHz-km			82		
	OM3 2000 MHz-km			300		

- Notes:
1. 10GBASE-SR
 2. Tested with a $2^{31} - 1$ PRBS

Datasheet

Environmental Specifications

Parameter	Symbol	Minimum	Typical	Maximum	Unit
Case Operating Temperature	T _{Op}	0	-	70	°C
Storage Temperature	T _{Sto}	-40	-	85	°C

Regulatory and Industry Compliances

MRV transceivers are Class 1 Laser Products and comply with US FDA regulations. These products are certified by TÜV and CSA to meet the Class 1 eye safety requirements of EN (IEC) 60825 and the electrical safety requirements of EN (IEC) 60950. Copies of certificates are available at MRV Corporation upon request.

Digital Diagnostics Functions

MRV's SFP-10GD-SX SFP+ transceivers support the 2-wire serial communication protocol as defined in the SFF-8472. It is very closely related to the E2PROM defined in the GBIC standard, with the same electrical specifications.

The standard SFP+ serial ID provides access to identification information that describes the transceiver's capabilities, standard interfaces, manufacturer, and other information.

Additionally, MRV's SFP+ transceivers provide an enhanced Digital Diagnostic monitoring interface that allows real-time access to device operating parameters such as transceiver temperature, laser bias current, transmitted optical power, received optical power, and transceiver supply voltage. It also defines a sophisticated system of alarm and warning flags that alert end-users when particular operating parameters are outside of a factory set normal range.

SFF-8472 defines a 256-byte memory map in E2PROM that is accessible over a 2-wire serial interface at the 8 bit address 1010000X (A0h). The Digital Diagnostic monitoring interface uses the 8-bit address 1010001X (A2h), so the originally defined serial ID memory map remains unchanged. The interface is identical to and fully backward compatible with both the GBIC specification and the SFP Multi Source Agreement.

The operating and diagnostics information is monitored and reported by a Digital Diagnostics Transceiver Controller (DDTC) inside the transceiver, which is accessed through a 2-wire serial interface. When the serial protocol is activated, the serial clock signal (SCL, Mod Def 1) is generated by the host. The positive edge clocks data to the SFP transceiver into those segments of the E2PROM that are not write-protected. The negative edge clocks data from the SFP transceiver. The serial data signal (SDA, Mod Def 2) is bi-directional for serial data transfer. The host uses SDA in conjunction with SCL to mark the start and end of serial protocol activation. The memories are organized as a series of 8-bit data words that can be addressed individually or sequentially.

Digital Diagnostics Specifications

Parameter	Symbol	Minimum	Typical	Maximum	Unit	Note
Accuracy						
Internally Measured Transceiver Temperature	DD _{Temperature}	-3	-	3	°C	-
Internally Measured Transceiver Supply Voltage	DD _{Voltage}	-100	-	100	mV	-
Measured TX Bias Current	DD _{Bias}	-10	-	10	%	1
Measured TX Output Power	DD _{Tx-Power}	-2	-	2	dB	-
Measured RX Received Average Optical Power	DD _{Rx-Power}	-2	-	2	dB	-
Dynamic Range for Rated Accuracy						
Internally Measured Transceiver Temperature	DD _{Temperature}	0	-	70	°C	-
Internally Measured Transceiver Supply Voltage	DD _{Voltage}	3.14	-	3.46	V	-
Measured TX Bias Current	DD _{Bias}	0	-	20	mA	-
Measured TX Output Power	DD _{Tx-Power}	-9	-	-2.5	dBm	-
Measured RX Received Average Optical Power	V _{EN}	-20	-	0	dBm	-
Max Reporting Range						
Internally Measured Transceiver Temperature	DD _{Temperature}	-40	-	125	°C	-
Internally Measured Transceiver Supply Voltage	DD _{Voltage}	2.8	-	4.0	V	-
Measured TX Bias Current	DD _{Bias}	0	-	20	mA	-
Measured TX Output Power	DD _{Tx-Power}	-10	-	-3	dBm	-
Measured RX Received Average Optical Power	DD _{Rx-Power}	-22	-	0	dBm	-

Notes: 1. Accuracy of Measured Tx Bias Current is 10% of the actual bias current from the laser driver to the laser.

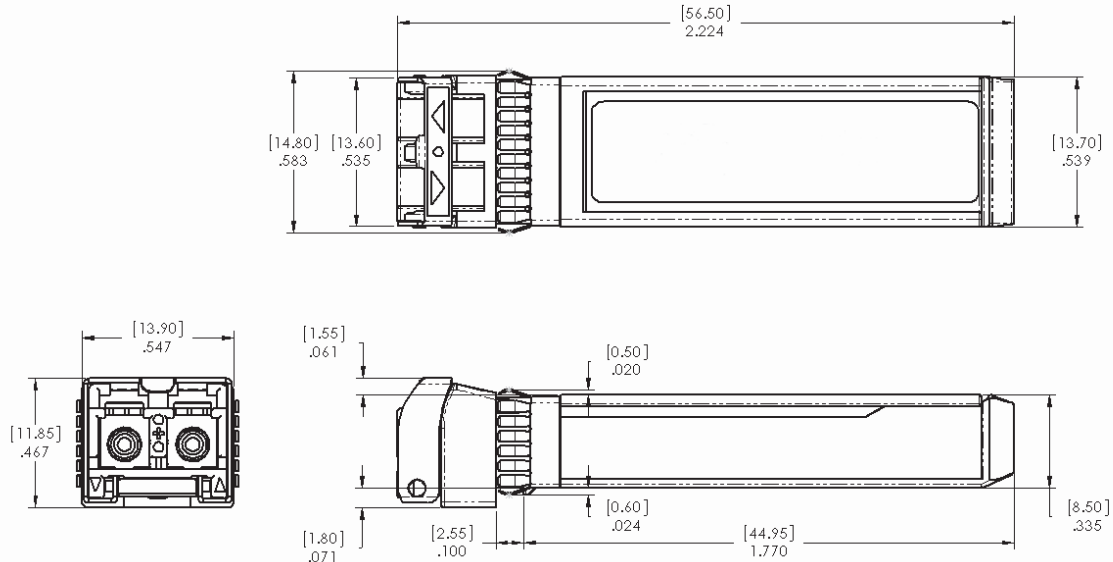
Datasheet
Mechanical Dimensions

Mechanical Specifications

MRV's SFP-10GD-SX SFP+ transceivers are compatible with the SFF-8432 specification for improved pluggable form-factor. The bail color is beige.

Ordering Information

Model	Description	Data Rate	Wavelength (nm)	Bail Latch Color	Max. Link Length (m)
SFP-10GD-SX	SFP+ Transceiver Multi-Mode	9.95 - 10.52 Gbps	850	Beige	0 -300*

*On 2000 MHZ-km multi-mode fiber

MRV has more than 50 offices throughout the world. Addresses, phone numbers and fax numbers are listed at www.mrv.com. Please e-mail us at sales@mrv.com or call us for assistance.

MRV Los Angeles
20415 Nordhoff St.
Chatsworth, CA 91311
800-338-5316
818-773-0900

MRV Boston
295 Foster St.
Littleton, MA 01460
800-338-5316
978-952-4700

MRV International
Business Park Moerfelden
Waldeckerstrasse 13
64546 Moerfelden-Walldorf
Germany
Tel. (49) 6105/2070
Fax (49) 6105/207-100

All statements, technical information and recommendations related to the products herein are based upon information believed to be reliable or accurate. However, the accuracy or completeness thereof is not guaranteed, and no responsibility is assumed for any inaccuracies. Please contact MRV Communications for more information. MRV Communications and the MRV Communications logo are trademarks of MRV Communications, Inc. Other trademarks are the property of their respective holders.