

Continuous Wave 488 nm Solid-State Laser

FCD488

**Key Features**

- Compact – optics and electronics integrated in one housing
- Low heat load – no heat sink required
- Good efficiency – requires only small 5 V power supply
- Fiber-based architecture – enables fiber-delivered version
- High reliability – due to telecom-style packaging technology

Applications

- Biotechnology
- Semiconductor instrumentation
- General instrumentation

The FCD488 is a continuous wave 10, 20 and 25 mW 488 nm solid-state laser, featuring fiber-based architecture. The package contains both the optical elements of the laser and the control electronics, allowing full control and diagnostics of the laser system through an analog interface and RS232 interface. Powered by an external 5 V DC power supply, the laser is cost-efficient, reliable, and compact, with excellent electrical and thermal efficiency. It has a low heat load, so the laser operates without a heat sink.

Based on JDSU's Frequency Converted Diode technology, the FCD488 enables consistent high volume laser manufacturing, with a "package, splice, and test" design. The components are put in hermetic packaging. The fibers are spliced together. And the laser is tested.

The FCD488 is available in two versions: a free space and a fiber-delivered version with the same characteristics and reliability as the free space laser.

2

Dimensions Diagram

(Specifications in mm unless otherwise noted.)

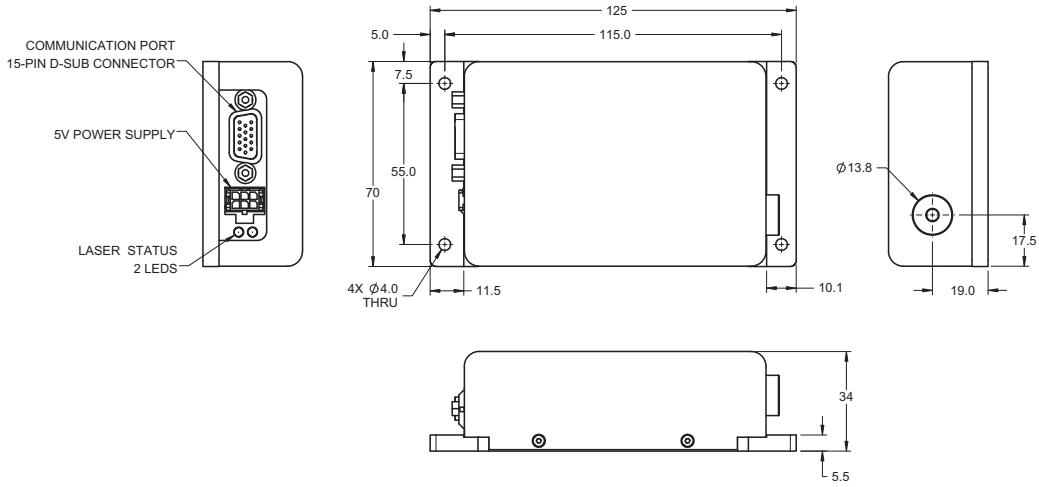

Free Space

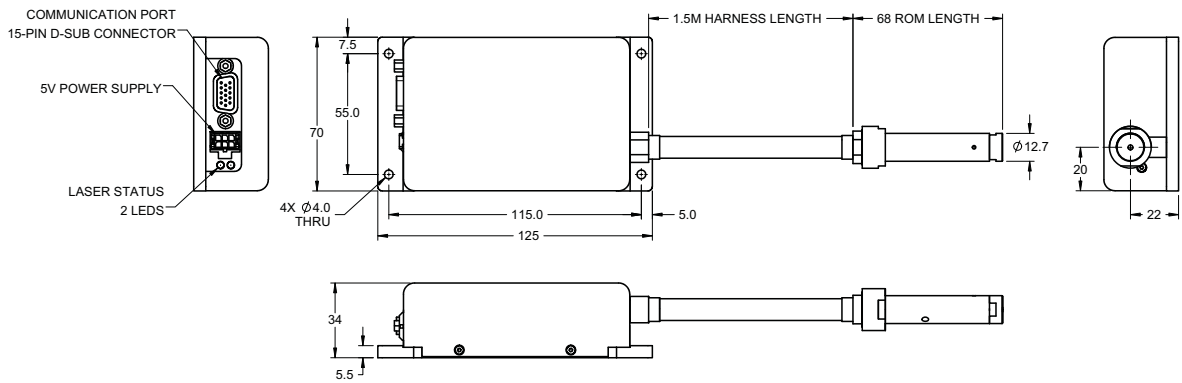

Fiber Delivered

3

Specifications

Parameter	FCD488-010 (Free Space)	FCD488-020 (Free Space)	FCD488-025 (Free Space)	FCD488FC-010 (Fiber Delivered)	FCD488FC-020 (Fiber Delivered)
Optical					
Wavelength	488 ± 2 nm				
Output power	10 mW	20 mW	25 mW	10 mW	20 mW
Power stability (2 hour, 25±3 °C) after warm-up	<2.0%				
Mode quality M ²	<1.2				
Beam diameter (1/e ² point)	0.7 mm ± 10%				
Beam divergence (full angle)	<1.0 mrad				
Polarization ratio (E-vector is vertical)	>100:1				
Noise (rms, 20 Hz to 2 MHz)	<0.5%				
Ellipticity	<10%				
Pointing stability after warm-up	<10 μrad/°C				
Static alignment					
Beam position	± 0.25 mm	± 0.25 mm	± 0.25 mm	± 0.5 mm	± 0.5 mm
Beam angle	± 2.5 mrad	± 2.5 mrad	± 2.5 mrad	± 50 mrad	± 50 mrad
Environmental					
Base plate temperature					
Operating	10 to 45°C				
Non-operating	0 to 60°C				
Shock (11 ms duration)					
Operating	1 g				
Non-operating	25 g				
Vibration (sinusoidal, 5 to 500 Hz)					
Operating	0.3 g				
Non-operating	2 g				
Warm-up time	<10 minutes				
Electrical requirements					
Operating voltage	5.0 ± 0.4 V DC				
Current required	4 A				

Ordering Information

For more information on this or other products and their availability, please contact your local JDSU account manager or JDSU directly at 1-800-498-JDSU (5378) in North America and +800-5378-JDSU worldwide, or via e-mail at customer.service@jdsu.com.

Sample: FCD488-010

Product Code	Description
FCD488-010	FCD continuous wave 10 mW 488 nm free space solid-state laser
FCD488-020	FCD continuous wave 20 mW 488 nm free space solid-state laser
FCD488-025	FCD continuous wave 25 mW 488 nm free space solid-state laser
FCD488FC-010	FCD continuous wave 10 mW 488 nm fiber delivered solid-state laser
FCD488FC-020	FCD continuous wave 20 mW 488 nm fiber delivered solid-state laser

Compliance with Regulatory Requirements

The FCD488 laser system is an OEM version of a JDSU solid-state laser and as such only intended for integration into other equipment. These lasers do not comply with CDRH. The customer is responsible for CDRH certification of the system incorporating the FCD488 laser system.

The unit has been designed and tested to comply with the following standards:

Electromagnetic radiated and line conducted emissions tested to standard EN 55022.

Electromagnetic immunity tested to standard EN 61326 in compliance with IEC 601010-1 and IEC 60825-1.

Warranty

JDSU FCD488 solid-state lasers are warranted to be free of defects in materials and workmanship for twelve months from the date of shipment or 5,000 hours, whichever occurs first.

