Programmable Bar Code Decode ICs

Technical Data

HBCR-2210 HBCR-2211

Features

- **Ideal for Hand Scanning and Non-contact Laser Scanning Applications**
- **Supports 7 Industry Standard Bar Code Symbologies**
- **Automatic Code Recognition**
- **Choice of Parallel or Serial Interface**
- **Full Duplex ASCII Interface**
- **Extensive Configuration Control**
- **Optical and Escape Sequence Configuration**
- **Input and Output Buffering**
- **Low Current (18 mA) CMOS Technology**
- **40 Pin DIP and 44 Pin PLCC Packages**
- **Audio and Visual Feedback Control**
- **EEPROM Support for Nonvolatile Configuration**
- **Single +5 Volt Supply**

Description

Hewlett-Packard's Bar Code Decoder ICs offer flexible bar code decoding capability that is designed to give OEMs the ability to address a growing number of industry segments and applications. Flexibility is made possible through sophisticated firmware which allows the ICs to accept data from a wide variety of scanners and to automatically recognize and decode the most popular bar code symbologies. User implementation of the decoder ICs is easy since it requires only a few supporting components and provides a standard I/O interface.

Manufacturers of data collection terminals, point of sale terminals, keyboards, weighing scales, medical equipment, test instrumentation, material handling equipment, and other systems having data collection needs are finding a growing demand for bar code reading capability in their products. The HBCR-2210 series decode ICs make it easy to add this capability without the need to

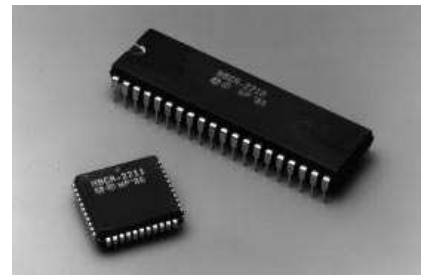

invest in the development of bar code decoding software.

The bar code decoder ICs are compatible with most hand held scanners and some medium speed machine mounted laser heads. The HBCR-2210 series is compatible with fixed beam non-contact scanners, digital wands, and slot readers. In addition, the decoder is optimized for use with the Symbol Technologies moving beam laser scanners, but is also compatible with many other moving beam non-contact laser scanners with a similar interface protocol.

The HBCR-2210 series decoder ICs are excellent decoding solu

tions for a number of stationary scanning applications found in automated systems. The scan rate for moving beam applications should be similar to the scan rates for hand held laser scanners (35 to 45 scans per second). The scan speed for fixed beam applications should be similar to the scan speeds typical of wands and slot readers. For moving beam applications, it is necessary for the scanner to utilize the three laser control lines.

The HBCR-2210 series decodes the most popular bar code symbologies now in use in applications in the industrial, retail, government and medical markets:

- **Code 39 (Standard or Extended)**
- **Interleaved 2 of 5**
- **UPC A, E**
- **EAN/JAN 8, 13**
- **Codabar**
- **Code 128**
- **Code 11**
- **MSI Code**

When more than one symbology is enabled, the bar code being scanned will automatically be recognized and decoded, except for Standard versus Extended Code 39, which are mutually exclusive. Bi-directional scanning is allowed for all bar codes except UPC/EAN/JAN with supplemental digits, which must be scanned with the supplemental digits last.

The I/O for the decode IC is full duplex, 7 bit ASCII. Both serial and parallel interfacing are available. The serial interface can be converted to an RS232C interface or connected directly to another microprocessor for data

processing. The parallel interface can be connected to a 74HC646 octal bus transceiver chip (or an equivalent part). Feedback to the operator is accomplished by signals for an LED and a beeper. In addition, there are many programmable functions that cover such items as code selection, good read beep tone, Header and Trailer buffers, laser scanning control, beeper tone, etc. See Table 2 for a complete list.

Performance Features

Bar Codes Supported

Code 39 is an alphanumeric code, while Extended Code 39 encodes the full 128 ASCII character set by pairing Code 39 characters. Both can be read bi-directionally with message lengths of up to 32 characters. An optional checksum character can be used with these codes, and the ICs can be configured to verify this character prior to data transmission.

Interleaved 2 of 5 code, a compact numeric only bar code, can also be read bi-directionally with message lengths from 4 to 32 characters. To enhance data accuracy, optional checksum character verification and/or message length checking can be enabled.

The following versions of UPC, EAN and JAN bar codes can be read bi-directionally: UPC-A, UPC-E, EAN-8, EAN-13, JAN-8, and JAN-13. All versions can be enabled simultaneously or decoding can be restricted to only the UPC codes. UPC, EAN, and JAN codes printed with complementary two or five digit supplemental encodings can be read in two different ways. If the

codes are enabled without the supplemental encodings, then only the main part of symbols printed with supplemental encodings will be read. If the reading of supplemental encodings is enabled, then only symbols with these supplements will be read. When supplemental encodings are enabled, the bar code symbols must be read in a direction which results in the supplements being scanned last.

Codabar, a numeric only bar code with special characters, can be read bi-directionally for message lengths up to 32 characters. The decode IC can be configured to transmit or suppress the Codabar start/stop characters.

Code 128, a full ASCII symbology, can be scanned bi-directionally with message lengths of up to 32 characters.

Code 11 is a numeric, high density code with one special character, the hyphen (-). Verification of one or two check characters must be enabled, and the check character(s) are always transmitted. This code can be scanned bi-directionally.

MSI Code is a numeric, continuous code, with message lengths up to 32 characters. The check digit, a modulo 10 checksum, is always verified and transmitted. This code can be scanned bi-directionally.

Scanner Input

The HBCR-2210 decode IC is designed to accept data from hand held digital scanners or slot readers with the following logic state: black = high, white = low. The same decode IC also accepts

data from hand held laser scanners with the opposite logic states: black = low, white = high. The scanner type pin (SCT) on the HBCR-2210 series must be driven prior to power up or hard reset to identify the type of scanner connected.

In the HBCR-2210 series ICs, the automatic laser shutoff feature delay time is adjustable as a configuration option. Applications which require increased accuracy may need the redundancy check feature.

Scanner input can be disabled by software command. This allows an application program to control when an operator can enter data, preventing inadvertent data entry. It also allows the program to verify each scan before enabling subsequent scans. The HBCR-2210 series also offers two Single Read Modes which allow the application program to stop bar code data entry until a "Next Read" command is received, allowing the host computer to process data transmissions before enabling subsequent reads.

Configuration Control and Non-volatile Storage

Configuration of the decoder IC is done by any of three methods. A minimal subset of key options can be "hardwired" – controlled by electrically strapping specified pins on the decoder IC itself. Which pins affect configuration depends on the selection of serial or parallel interface. Alternatively, ASCII characters in the form of HP Escape Sequences (a format common to HP decoder ICs) can be sent to the serial or parallel I/O port; these commands can be used to control all configurable

options. A third method is optical configuration, which makes use of special bar code menus supplied by HP. Menu labels can be created to modify any configurable options. A summary of the decoder IC features and applicable configuration methods for each is presented in Tables 2 and 3.

Once configuration has been set, it can be stored in an optional non-volatile memory, if included in the decoder circuit. When the EEP pin is tied high, the decoder IC drives I/O lines compatible with the widely available 9346/93C46 family of serial EEPROMS. The configuration is thereby saved during power down of the system and automatically reloaded at power up. Escape sequence commands allow explicit storage and recall of configuration settings. When using optical configuration, storage is automatic. If the EEP pin is tied low, the EEPROM is not used, so only hardwired configuration options are saved through powerdown; all others are set to default values at powerup. Table 2 shows default values of all features.

Data Communications

The serial port supports a wide range of baud rates, parities, and stop bits as described in Table 2. Software control of data transmission can be accomplished with a standard Xon/Xoff (DC1/DC3) handshake. The decode IC also supports an RTS/CTS hardware handshake.

The parallel port data has configurable parity. When the SMD pin is tied low, several pins pertaining to the serial port change

function to control a parallel port instead. Pins 1 through 5 on DIP packages assume the function of handshake lines for the parallel port. The port itself is an external '646 family octal bus transceiver. Processor pins 10 and 11 (TXD and RXD in serial mode) now control the transceiver chip along with pins 16 and 17, RD and WR. Alternative circuits using SSI latch chips can be substituted for the '646 implementation to customize the function of the parallel port to a particular bus configuration.

Feedback Features

Both audio and visual feedback are possible with the HBCR-2210 series. In both cases, the outputs from the ICs should be buffered before driving the actual feedback transducer. An LED or beeper connected to the decoder IC can be controlled directly by the IC, with signals generated by successful decodes, or can be controlled by the host system. In addition, the tone of the beeper can be configured to be one of 16 different frequencies, or can be silenced.

Power Requirements

The decoder IC operates from a +5 volt DC power supply. The maximum current draw is 18 mA. The maximum power supply ripple voltage should be less than 100 mV, peak-to-peak.

Handling Precautions

The decoder ICs are extremely sensitive to electrostatic discharge (ESD). It is important that proper anti-static procedures be observed when handling the ICs. The package should not be



opened except in a static free environment.

Manuals

The decode IC Users Manual covers the following topics:

- Data output formats
- I/O interfaces
- Laser input timing diagrams
- Escape sequence syntax and functionality
- Example schematics
- All configurable options
- Bar code menus
- Scanner positioning and tilt
- Sample bar code symbols
- Appendices describing bar code symbologies

Table 1. Ordering Information

Part Number	Description
HBCR-2210	CMOS, 40 pin DIP, bulk ship, no manual
HBCR-2211	CMOS, 44 pin PLCC, bulk ship, no manual
OPT A01	IC individually boxed with manual and data sheet
HBCR-2297	HBCR-2210 Series Users Manual

Recommended Operating Conditions

Parameter	Symbol	Minimum	Maximum	Units	Notes
Supply Voltage	V_{CC}	4.0	6.0	V	1
Ambient Temperature	T_A	-40	+85	°C	
Crystal Frequency	XTAL	0 (DC)	11.059	MHz	2
Element Time Interval (Moving Beam)	ETI_M	13	555	µs	2, 3, 4
Element Time Interval (Contact Scanner)	ETI_C	50	71000	µs	3, 4

Notes:

1. Maximum power supply ripple of 100 mV peak to peak.
2. The HBCR-2210 series uses a 11.059 MHz crystal. For different crystal frequencies, multiply the specified baud rate and beeper frequencies by (crystal frequency/11.059 MHz) and multiply the element time interval ranges by (11.059 MHz/crystal frequency).
3. At the specified crystal frequency.
4. Corresponds to a scan rate of 35 to 45 scans per second.

Absolute Maximum Ratings

Parameter	Symbol	Minimum	Maximum	Units	Notes
Storage Temperature	T_S	-55	+150	°C	
Supply Voltage	V_{CC}	-0.5	+7.0	V	5
Pin Voltage	V_{IN}	-0.5	$V_{CC} + 0.5$	V	5, 6

Notes:

5. $T_A = 25^\circ\text{C}$.
6. Voltage on any pin with respect to ground.

DC Characteristics

HBCR-2210, 2211

($T_A = 40^\circ\text{C}$ to $+85^\circ\text{C}$, $V_{CC} = 4.5\text{ V}$ to 5.5 V , $V_{SS} = 0\text{ V}$)

Symbol	Parameter	HBCR-2210 Pins	HBCR-2211 Pins	Min.	Max.	Units	Test Conditions
V_{IL}	Input Low Voltage	all	all	-0.5	$0.2 V_{CC} - 0.1$	V	
V_{IH}	Input High Voltage	except 9, 18	except 10, 20	$0.2 V_{CC} + 0.9$	$V_{CC} + 0.5$	V	
V_{IH1}	Input High Voltage	9, 18	10, 20	$0.7 V_{CC}$	$V_{CC} + 0.5$	V	
V_{OL}	Output Low Voltage	1-8, 10-17, 21-28	2-9, 11, 13-19, 24-31		0.45	V	$I_{OL} = 1.6\text{ mA}$
V_{OL1}	Output Low Voltage	30, 32-39	33, 36-43		0.45	V	$I_{OL} = 3.2\text{ mA}$
V_{OH}	Output High Voltage	1-8, 10-17, 21-28	2-9, 11, 13-19, 24-31	2.4		V	$I_{OH} = -60\ \mu\text{A}$
				$0.75 V_{CC}$		V	$I_{OH} = -30\ \mu\text{A}$
				$0.9 V_{CC}$		V	$I_{OH} = -10\ \mu\text{A}$
V_{OH}	Output High Voltage	30, 32-39	33, 36-43	2.4		V	$I_{OH} = -400\ \mu\text{A}$
				$0.75 V_{CC}$		V	$I_{OH} = -150\ \mu\text{A}$
				$0.9 V_{CC}$		V	$I_{OH} = -40\ \mu\text{A}$
I_{IL}	Input Low Current	1-8, 10-17, 21-28	2-9, 11, 13-19, 24-31	-10	-200	μA	$V_{IN} = 0.45\text{ V}$
I_{IL2}	Input Low Current	18	20		-3.2	mA	$V_{IN} = 0.45\text{ V}$
I_{LI}	Input Leakage Current	32-39	36-43		± 10	μA	$0.45 \leq V_{IN} \leq V_{CC}$
R_{RST}	Pulldown Resistor	9	10	20	125	K Ω	
I_{CC}	Power Supply Current	-	-		18	mA	All Outputs disconnected
I_{CC}	Idle Mode Power Supply Current	-	-		9	mA	Note 7.

Note:

7. Applies only to HBCR-2210 and -2211 in Wand Mode or Laser Mode with Laser Idling enabled with no scanning or I/O operation in progress.

Table 2. Summary of Features and Configurations - HBCR-2210 Series

In the table below, the column entitled Selection is either:

Software Escape Sequence and Optical Menu Programmability
 Hardware Control of a feature by electrically strapping specified pins on the decoder IC itself
 Both Both Software and Hardware

Feature	Function or Value	Selection	Default Setting
Code Selection	When a symbology is enabled, bar codes of that type can be read, assuming that other decoding options are satisfied.	Both	Decoding of all codes is enabled
Minimum/Maximum Label Length Selection	Code 39, Codabar, Code 128, Code 11, and MSI Code	Software	Min. = 1 Max. = 32
	Interleaved 2 of 5	Software	Min. = 4 Max. = 32
Interleaved 2 of 5 Specific Label Length Selection	Length variable from 4 to 32, or a specific even length between 2 and 32, or lengths 6 and 14 only	Software	4 to 32

(continued)

Feature	Function or Value	Selection	Default Setting
Check Character Verification Enable	For Code 39 For Interleaved 2 of 5 When enabled, the check character at the end of the bar code data is verified by the decoder	Software Software	Disabled Disabled
Check Character Transmission Enable	For both Code 39 and Interleaved 2 of 5, the check characters verified by the reader are included at the end of the decoded message	Software	Disabled
Code 39 Full ASCII Conversion Enable	Extended Code 39 data will be converted to ASCII characters	Software	Disabled
UPC/EAN/JAN Decoding Options Selection	UPC/EAN/JAN vs. UPC only Enable 2 or 5 digit supplements Autodiscrimination of tags with and without supplements	Software Software	UPC/EAN/JAN Enabled Supplements Disabled Disabled
Codabar Data Start/Stop Transmission Enable	Transmit or suppress start/stop characters	Software	Transmit
Code 11 Check Digit Verification Selection	Selection of 1 or 2 check digits	Software	1 check digit
Baud Rates	150, 300, 600, 1200, 2400, 4800, 9600, 19200	Both	Depends on pins BR1, BR0, and SMD
Parity	0s, 1s, Odd, Even	Both	Depends on pins EEP, PT1 and PT0
Stop Bits	1 or 2	Both	Depends on pins SMD and STB
RTS/CTS Pacing Enable	Request-To-Send/Clear-To-Send Pacing controls serial port data transmission	Software	Enabled
Xon/Xoff Pacing Enable	Controls data transmission on serial or parallel port by means of control characters sent to decoder IC	Software	Disabled
Transmitted Character Delay Enable	Specifies whether a delay is inserted between characters transmitted on the serial port	Software	Disabled
Transmitted Character Delay Selection	Specifies the number of milliseconds to insert between completion of transmission of one character and beginning of transmission of the next (1 to 250 ms)	Software	20 msec

(continued)

Feature	Function or Value	Selection	Default Setting
Header Selection	A string of characters pre-pended to the decoded message (10 characters, maximum)	Software	none
Trailer Selection	A string of characters appended to the decoded message (10 characters, maximum)	Software	C _R L _F
Reader Address Selection	Reader Address is transmitted at the beginning of decoded and No-Read messages for polling purposes. (1 character)	Software	none
Message Ready/Not Ready Response Selection	The Message Ready/Not Ready response is transmitted after the reader receives a status request type 3 and is used with Single Read Mode 2. (1 character each)	Software	ACK/NAK
No-Read Message Selection	The No-Read Message configured is transmitted each time there is an unsuccessful read (10 characters, maximum)	Software	none
No-Read Recognition Enable	Controls whether the decoder detects unsuccessful reads and sends the No-Read Message	Software	Disabled
Single Read Mode 1 Enable	Controls reading and automatic transmission of decoded messages	Software	Disabled
Single Read Mode 2 Enable	Controls separate reading of bar codes and triggering decoded message transmission	Software	Disabled
Output Buffering Enable	Characters to be transmitted are entered into a 256 character queue for use with a pacing protocol	Software	Disabled
Scanner Type Selection	Determines whether a wand or laser is to be used	Hardwire	Depends on pin SCT
Laser Shutoff Delay Selection	Defines laser on time prior to automatic shutoff, from 0 to 10 seconds in 100 ms steps	Software	3 seconds
Laser Redundancy Check Enable	Enables requirement for two consecutive, identical decodes for a good read	Software	Disabled
Continuous Laser Read Mode Enable	When enabled, the laser is turned on permanently instead of waiting for the trigger to be pulled	Software	Disabled

(continued)

Feature	Function or Value	Selection	Default Setting
Laser Connection Detection Enable	When enabled, the scanner type pin is ignored at powerup. Instead, the decoder tests for a laser scanner to determine scanner type	Software	Disabled
Laser Trigger Latch Mode Enable	When enabled, the laser scanner continues to scan after the trigger has been released until either the laser shutoff delay period elapses or a read occurs	Software	Disabled
Laser Idling Enable	When enabled, the processor idles while waiting for the trigger to be pulled, reducing current draw	Software	Disabled
Code ID Character Selection	Code ID character serves to identify the symbology of the decoded message	Software	Code 39 = a Int 2/5 = b UPC/EAN = c Codabar = d Code 128 = e Code 11 = f MSI Code = g
Code ID Character Transmission Enable	Code ID character can be added to the beginning of each decoded message	Software	Disabled
Bar Code Menu Scan Response Enable	Verification of individual configuration menu scans via transmission of response message	Software	Disabled
Hard Reset Message Enable	“Ready 12.4” C _R L _F will be transmitted to host upon hard reset	Software	Disabled
ROM, RAM Self Test Enable	When enabled, ROM and RAM are tested after a Hard Reset	Software	Enabled
Good Read Beep Tone Selection	Selects Good Read Beep tones (1 to 16)	Software	Tone 12
LED Control Selection	Controls the LED function: Automatic Flash Mode Automatic Feedback Mode		Enabled Disabled
LED Active Level Selection	Defines logic level of LED ON state	Software	Active High
LED, Beeper Feedback Suppression Enable	Suppresses LED and Beeper operation for systems without those annunciators	Software	Not Suppressed
Wand Input Buffering Enable	Data from wand scans is collected continuously in an input buffer to increase throughput	Software	Disabled
Quiescent State of Address Line Selection	The quiescent state of the processor memory bus address lines A8, A9, A10 can be defined for additional I/O interfacing	Software	High

Table 3. Summary of Commands - HBCR-2210 Series

Features	Description
Scanner Enable	When enabled, scans with the wand or laser are decoded; otherwise, they are ignored
Hard Reset	Resets decoder IC as though it were just powered up
Soft Reset	Clears pacing conditions, errors
LED Control Selection	Controls the LED On/Off function
Status Requests	Cause the decoder to generate a status message <ul style="list-style-type: none"> • General status message showing symbology of last message read, error conditions, etc. • Message Ready/Not Ready response (for Single Read Mode 2)
Sound Tone	This command causes the reader to sound a tone at the selected pitch for approximately 100 milliseconds
Configuration Control	There are three operations that manipulate the decoder configuration as a block. <ul style="list-style-type: none"> • Set default configuration • Save configuration in non-volatile memory • Recall non-volatile configuration
Execute Pending Command	For use with laser scanning, this command causes immediate execution of previous commands that would otherwise be postponed until the laser scan finishes

Table 4. Summary of Other Features - HBCR-2210 Series

Power Idle Mode	Reduces current draw of processor from approximately 20 mA to 4 mA in wand mode when the wand is inactive
Laser Failure Timeout	Turns off the laser if the Scan Sync signal is missing after approximately 1 second, and sets the laser failure status bit
Self Test Failure Message	An appropriate message is transmitted at power up if the decoder Self Test fails. <ul style="list-style-type: none"> • ROM SELF TEST FAILED • EEPROM SELF TEST FAILED • RAM SELF TEST FAILED
EEPROM Fault Recognition	An appropriate message is transmitted at power up if the EEPROM checksum is incorrect. <ul style="list-style-type: none"> • EEPROM FAULT

Parallel Mode Handshake Timing

Handshake and Data Lines

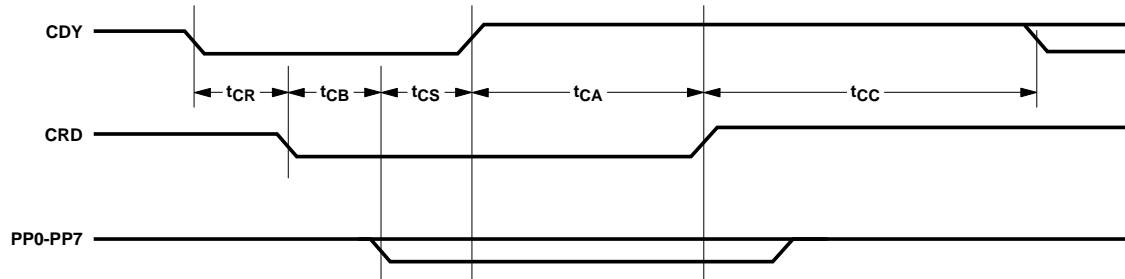

Figure 1. Host Commands Received by Decode IC (Reader).

Handshake Timing

t_{CR} = Falling edge of command ready to falling edge of command read. Max. = 30 μ s for the first byte of transmission from host.

t_{CB} = Falling edge of command read to command valid. Min. = 0 μ s

t_{CS} = Command valid set up to rising edge of command ready. Min. = 0 μ s

t_{CA} = Rising edge of command ready to rising edge of command read. Max. = 8 μ s

t_{CC} = Rising edge of command read to falling edge of command ready. Min. = 0 μ s

Handshake and Data Lines

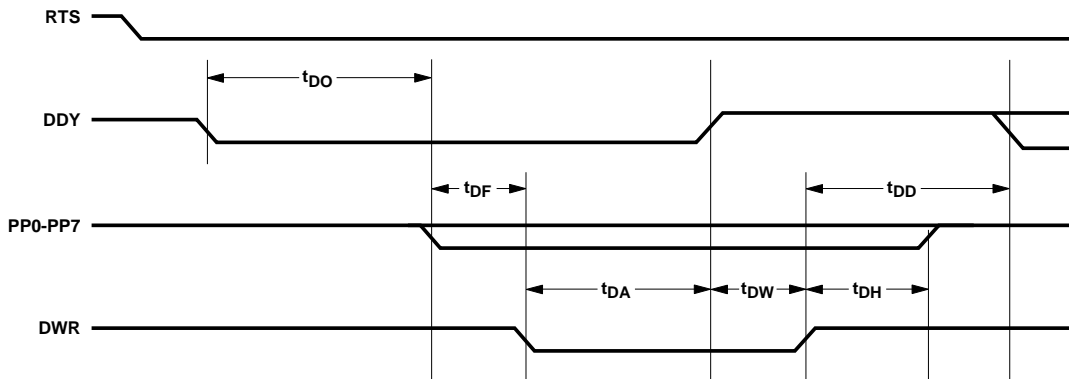

Figure 2. Decoder IC Data Sent to Host.

Handshake Timing

t_{DO} = Falling edge of data ready to data output to bus. Min. = 6 μ s Typical Max. = 74 μ s

Note: The maximum can be infinite if there is no data to be transmitted. RTS can be used to determine when there is data. If the scanner is active or escape sequence commands are being processed, ($t_{DO} = t_{DF}$) can extend by an indefinite amount.

t_{DF} = Data output to bus to falling edge of data write. Max. = 6 μ s

t_{DA} = Falling edge of data write to rising edge of data ready. Min. = 0 μ s

t_{DW} = Rising edge of data ready to rising edge of data write. Max. = 8 μ s

t_{DH} = Data hold after rising edge of data write. Max. = 4 μ s

t_{DD} = Rising edge of data write to falling edge of data ready. Min. = 0 μ s

PLCC Drying

Whenever Vapor Phase or Infrared Reflow Technologies are used to mount the PLCC packages, there is a possibility that previously absorbed moisture, heated very rapidly to the reflow temperatures, may cause the package to crack from the internal stresses. There is a reliability concern that moisture may then enter the package over a period of time, and metal corrosion may take place, degrading the IC performance.

To reduce the amount of absorbed moisture and prevent cracking, all of the PLCC ICs should undergo one of the

following baking cycles. The parts must then be mounted within 48 hours.

If the parts are not mounted within 48 hours, they must be re-baked.

The total number of baking cycles must not exceed two. If the ICs are baked more than twice,

Hewlett-Packard cannot guarantee the performance and reliability of the parts.

Neither bake cycle can be performed in the standard shipping tubes. The ICs must be baked in an ESD safe, mechanically stable container, such as an aluminum tube or pan.

Cycle	Temperature	Time	Notes
A	125°C	24 hrs	
B	60°C	96 hrs	8

Note:

8. Cycle B must be done in atmosphere of <5% relative humidity air or nitrogen.

Pin Definitions

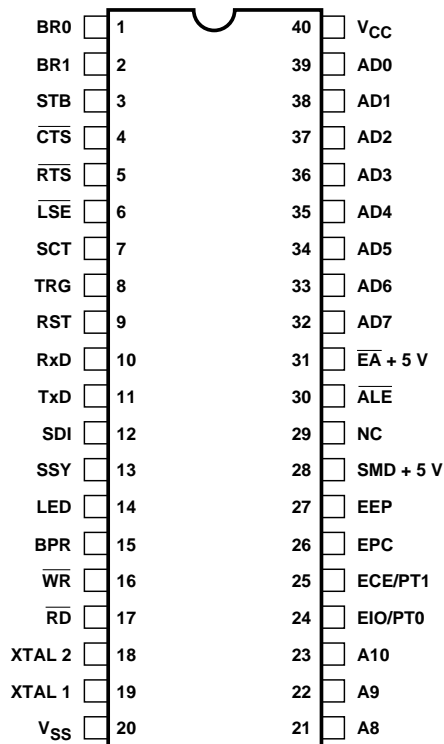

PIN MNEMONICS	
AD0-AD7	ADDRESS/DATA BUS
RxD	RECEIVED DATA
TxD	TRANSMITTED DATA
BR0-BR1	BAUD RATE
PT0-PT1	PARITY
STB	STOP BITS
LSE	LASER SCAN ENABLE
SCT	SCANNER TYPE
SDI	SCANNER DIGITAL INPUT
LED	LED CONTROL LINE
BPR	BEEPER CONTROL LINE
WR	DATA MEMORY WRITE
RD	DATA MEMORY READ
XTAL1	CRYSTAL INPUT
XTAL2	CRYSTAL INPUT
SMD	SERIAL MODE SELECT
RTS	REQUEST TO SEND
CTS	CLEAR TO SEND
RST	IC RESET
EEP	EEPROM SELECT
EPC	EEPROM CLOCK
ECE	EEPROM CHIP ENABLE
EIO	EEPROM I/O
TRG	LASER TRIGGER LINE
SSY	SCANNER SYNCHRONIZATION
A8	ADDRESS LINE #8
A9	ADDRESS LINE #9
A10	ADDRESS LINE #10
EA	EXTERNAL PROGRAM ENABLE
ALE	ADDRESS LATCH ENABLE
VCC	POWER
VSS	GROUND

Figure 3. HBCR-2210 Serial Pinout.

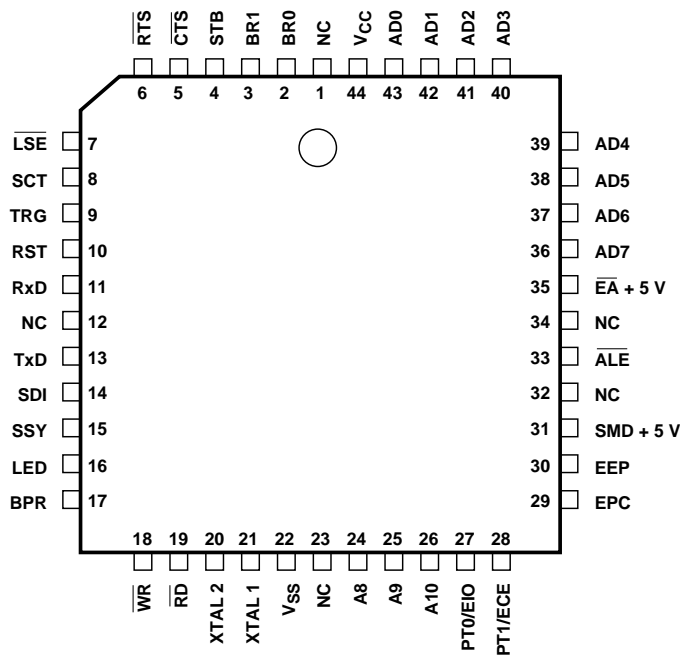

PIN MNEMONICS	
AD0-AD7	ADDRESS/DATA BUS
RxD	RECEIVED DATA
TxD	TRANSMITTED DATA
BR0-BR1	BAUD RATE
PT0-PT1	PARITY
STB	STOP BITS
LSE	LASER SCAN ENABLE
SCT	SCANNER TYPE
SDI	SCANNER DIGITAL INPUT
LED	LED CONTROL LINE
BPR	BEEPER CONTROL LINE
WR	DATA MEMORY WRITE
RD	DATA MEMORY READ
XTAL1	CRYSTAL INPUT
XTAL2	CRYSTAL INPUT
SMD	SERIAL MODE SELECT
RTS	REQUEST TO SEND
CTS	CLEAR TO SEND
RST	IC RESET
EEP	EEPROM SELECT
EPC	EEPROM CLOCK
ECE	EEPROM CHIP ENABLE
EIO	EEPROM I/O
TRG	LASER TRIGGER LINE
SSY	SCANNER SYNCHRONIZATION
A8	ADDRESS LINE #8
A9	ADDRESS LINE #9
A10	ADDRESS LINE #10
EA	EXTERNAL PROGRAM ENABLE
ALE	ADDRESS LATCH ENABLE
VCC	POWER
VSS	GROUND

Figure 4. HBCR-2211 Serial Pinout.

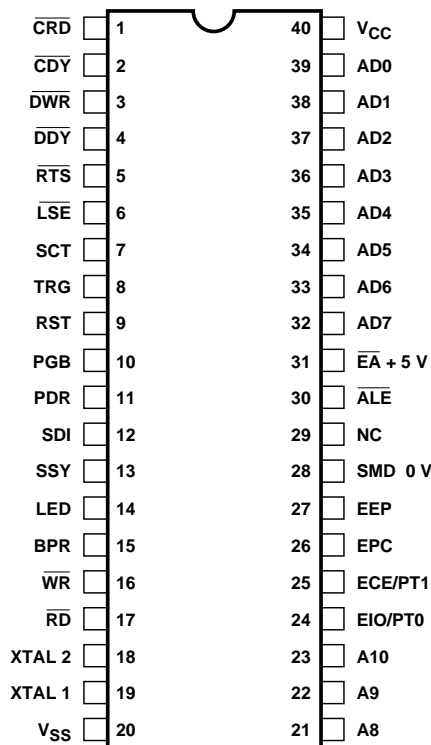

PIN MNEMONICS	
AD0-AD7	ADDRESS/DATA BUS
DWR	DATA WRITE HANDSHAKE
DDY	READY FOR DATA HANDSHAKE
CRD	COMMAND READ HANDSHAKE
CDY	COMMAND READY HANDSHAKE
PT0-PT1	PARITY
LSE	LASER SCAN ENABLE
SCT	SCANNER TYPE
SDI	SCANNER DIGITAL INPUT
LED	LED CONTROL LINE
BPR	BEEPER CONTROL LINE
WR	DATA MEMORY WRITE
RD	DATA MEMORY READ
XTAL1	CRYSTAL INPUT
XTAL2	CRYSTAL INPUT
SMD	SERIAL MODE SELECT
PGB	TRANSCEIVER DRIVE ENABLE
PDR	TRANSCEIVER DIRECTION CONTROL
RST	IC RESET
EEP	EEPROM SELECT
EPC	EEPROM CLOCK
ECE	EEPROM CHIP ENABLE
EIO	EEPROM I/O
TRG	LASER TRIGGER LINE
SSY	SCANNER SYNCHRONIZATION
A8	ADDRESS LINE #8
A9	ADDRESS LINE #9
A10	ADDRESS LINE #10
EA	EXTERNAL PROGRAM ENABLE
ALE	ADDRESS LATCH ENABLE
RTS	REQUEST TO SEND
VCC	POWER
VSS	GROUND

Figure 5. HBCR-2210 Parallel Pinout.

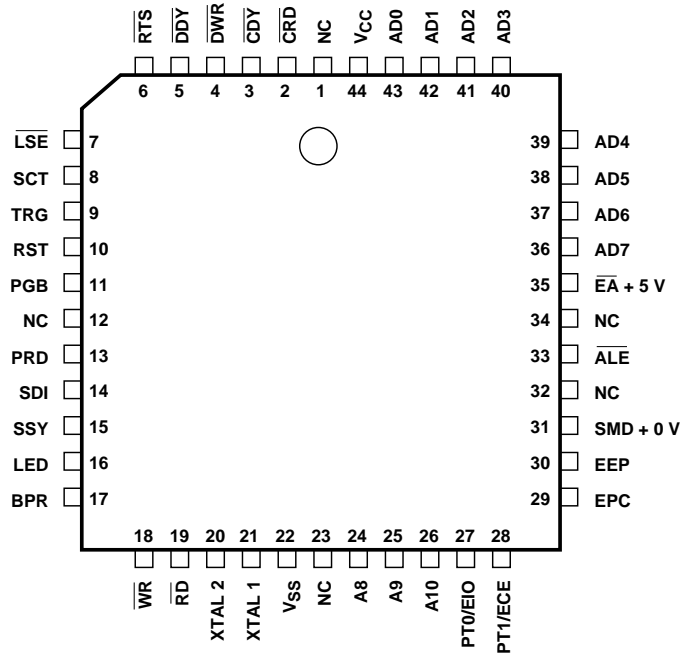

PIN MNEMONICS	
AD0-AD7	ADDRESS/DATA BUS
$\overline{\text{DWR}}$	DATA WRITE HANDSHAKE
$\overline{\text{DDY}}$	READY FOR DATA HANDSHAKE
$\overline{\text{CRD}}$	COMMAND READ HANDSHAKE
$\overline{\text{CDY}}$	COMMAND READY HANDSHAKE
PT0-PT1	PARITY
LSE	LASER SCAN ENABLE
SCT	SCANNER TYPE
SDI	SCANNER DIGITAL INPUT
LED	LED CONTROL LINE
BPR	BEEPER CONTROL LINE
WR	DATA MEMORY WRITE
RD	DATA MEMORY READ
XTAL1	CRYSTAL INPUT
XTAL2	CRYSTAL INPUT
SMD	SERIAL MODE SELECT
PGB	TRANSCEIVER DRIVE ENABLE
PDR	TRANSCEIVER DIRECTION CONTROL
RST	IC RESET
EEP	EEPROM SELECT
EPC	EEPROM CLOCK
ECE	EEPROM CHIP ENABLE
EIO	EEPROM I/O
TRG	LASER TRIGGER LINE
SSY	SCANNER SYNCHRONIZATION
A8	ADDRESS LINE #8
A9	ADDRESS LINE #9
A10	ADDRESS LINE #10
$\overline{\text{EA}}$	EXTERNAL PROGRAM ENABLE
$\overline{\text{ALE}}$	ADDRESS LATCH ENABLE
RTS	REQUEST TO SEND
V_{CC}	POWER
V_{SS}	GROUND

Figure 6. HBCR-2211 Parallel Pinout.

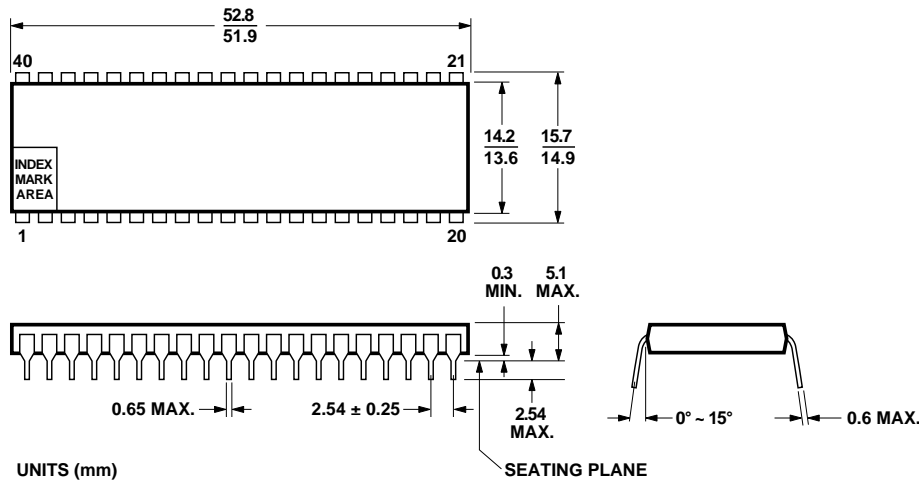

Figure 7. HBCR-2210 Mechanical Specifications.

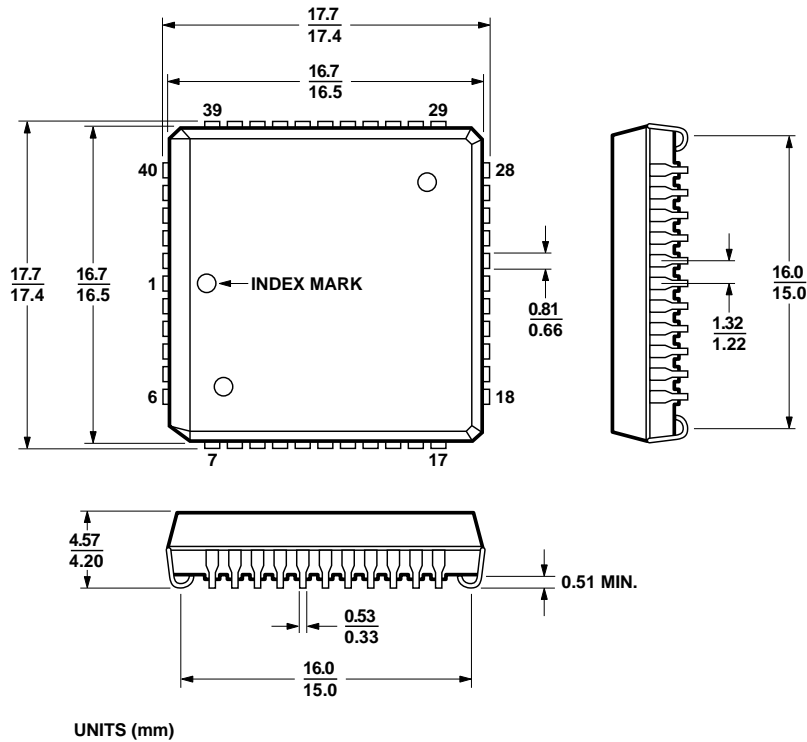

Figure 8. HBCR-2211 Mechanical Specifications.

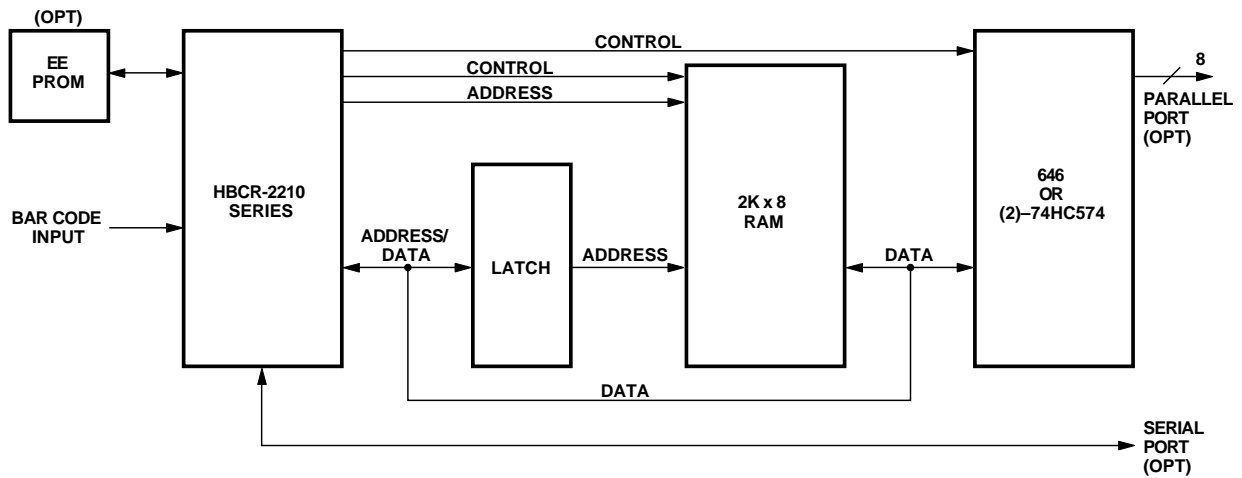

Figure 9. System Block Diagram.

Warranty and Service

The HP Bar Code Decode IC is warranted for a period of one year after purchase covering defects in material and workmanship. Hewlett-Packard will repair or, at its option, replace products that prove to be defective in material or workmanship under proper use during the warranty period.

NO OTHER WARRANTIES ARE EXPRESSED OR IMPLIED, INCLUDING BUT NOT LIMITED TO THE IMPLIED WARRANTIES OF MERCHANTABILITY AND FITNESS FOR A PARTICULAR PURPOSE. HEWLETT-PACKARD IS NOT LIABLE FOR CONSEQUENTIAL DAMAGES.

For additional warranty or service information please contact your local Hewlett-Packard sales representative or authorized distributor.