

# S SERIES

## Thin Film Resistor Network Isolated and Bussed Circuits RoHS compliant available



### FEATURES

Precision Nichrome Resistors on Silicon	
Industry Standard Packaging	JEDEC 95
Ratio Tolerances	< ±0.05%
TCR Tracking Tolerances	< ±5 ppm/°C

### SCHEMATICS

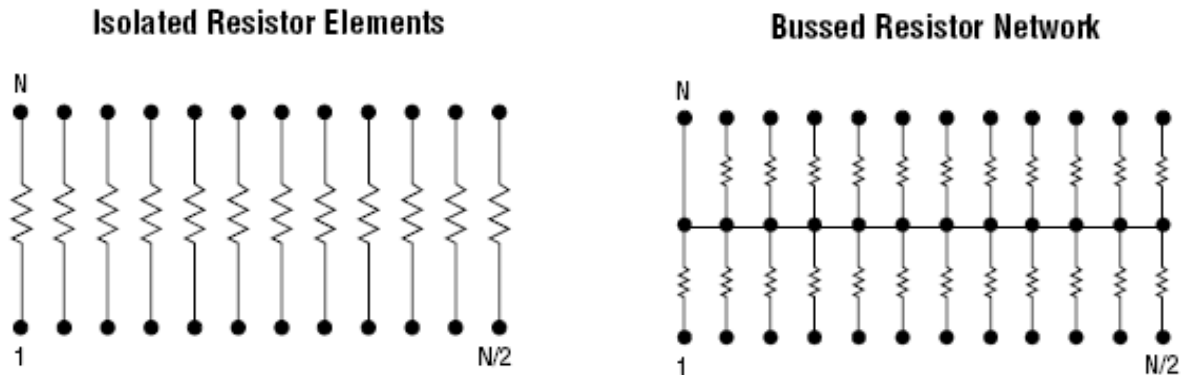

### ELECTRICAL<sup>1</sup>

Standard Resistance Range, Ohms <sup>2</sup>	1K to 100K (Isolated) 1K to 30K (Bussed)
Resistor Tolerances	±0.1%
Ratio Tolerances	±0.05%
TCR	Reference TCR table
Operating Temperature Range	-55°C to +125°C
Interlead Capacitance	<2pF
Insulation Resistance	≥10,000 Megohms
Maximum Operating Voltage	100Vdc or √PR
Noise, Maximum (MIL-STD-202, Method 308)	-25dB
Resistor Power Rating at 70°C	0.1 watts

<sup>1</sup> Specifications subject to change without notice.

<sup>2</sup> E24 codes available.

**BI Technologies Corporation**

4200 Bonita Place  
Fullerton, CA 92835 USA

Website: [www.bitechnologies.com](http://www.bitechnologies.com)

August 25, 2006

page 1 of 3



# Nichrome on Silicon

## PACKAGE POWER, WATTS @ 70°C<sup>3</sup>

QSOP			SOIC (Narrow)			SOIC (Wide)			P-DIP		
16	20	24	8	14	16	16	20	24	8	14	16
0.75	1.0	1.0	0.4	0.7	0.8	1.0	1.2	1.2	0.4	0.6	0.8

## POWER DERATING CURVE

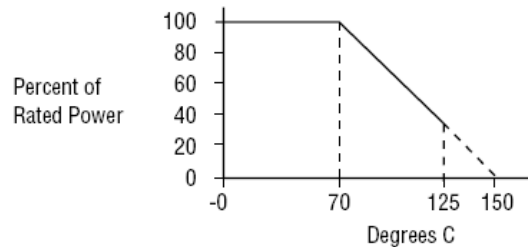

## ENVIRONMENTAL (MIL-R-83401)

Thermal Shock plus Power Conditioning	ΔR 0.1%
Short Time Overload	ΔR 0.1%
Terminal Strength	ΔR 0.1%
Moisture Resistance	ΔR 0.1%
Mechanical Shock	ΔR 0.1%
Vibration	ΔR 0.1%
Low Temperature Operation	ΔR 0.05%
High Temperature Exposure	ΔR 0.1%
Resistance to Solder Heat	ΔR 0.1%
Marking Permanency	Per MIL-STD-202, Method 215
Flammability	UL-94V-0 Rated
Storage Temperature Range	-55°C to +125°C

## MECHANICAL

Lead Plating	80/20 Tin Lead (Standard) 100 matt Tin (RoHS)
Lead Material	Copper Alloy
Lead Configuration	Gull Wing
Lead Coplanarity	0.004" (0.102 mm)
Substrate Material	Silicon
Resistor Material	Passivated Nichrome
Body Material	Molded Epoxy

<sup>3</sup> Power per resistor @ 70 °C, Maximum is 100 mW, not to exceed package power

**BI Technologies Corporation**

4200 Bonita Place  
Fullerton, CA 92835 USA

Website: [www.bitechnologies.com](http://www.bitechnologies.com)

August 25, 2006

page 2 of 3



# Nichrome on Silicon

## ORDERING INFORMATION<sup>4</sup>

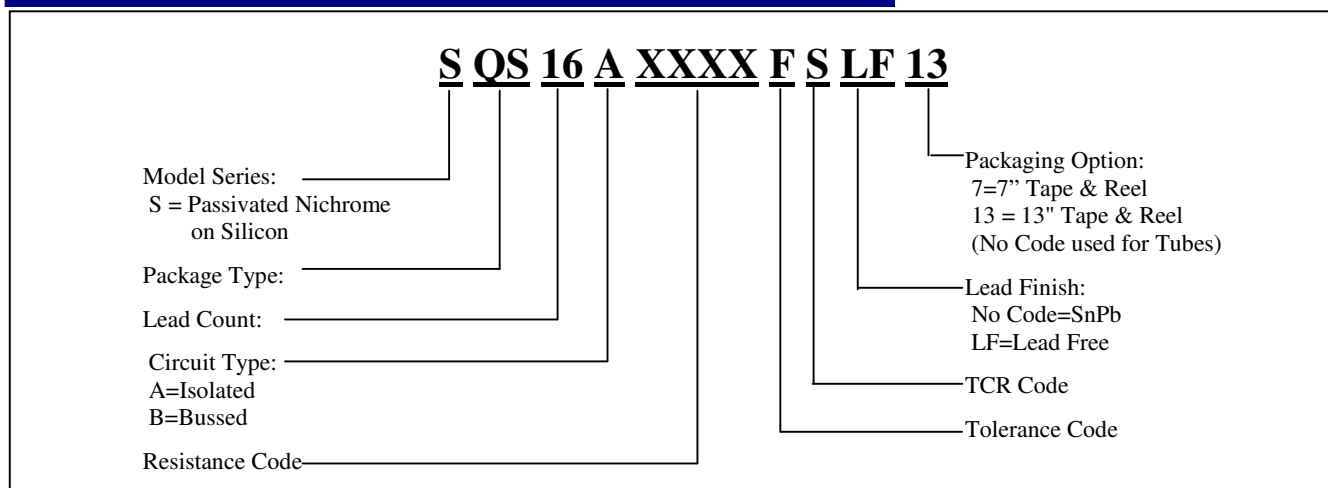

## PACKAGE TYPE

	Package Codes	Lead count	Mechanical Outline <sup>5</sup>
QSOP	QS	16,20, 24	MO-137
SOIC Narrow Body	SN	8, 14, 16	MS-012
SOIC Wide Body	SW	16	MS-013
P-DIP	PD	8, 14, 16	MS-001

## RESISTANCE<sup>6</sup>

First 3 digits are significant. Fourth digit denotes number of trailing zeros. For values less than 100, use "R" to denote a decimal point. Example, 51 and 10000 ohms is coded as 51R0 and 1002 respectively.

## RESISTANCE TOLERANCE<sup>5</sup>

Accuracy Code at 25°C	A	B	D	F	G	J
Absolute Resistance Tolerances (%)	±0.1	±0.1	±0.5	±1.0	±2.0	±5.0
Ratio Tolerances (R1 Ref) (%)	±0.05	±0.1	±0.1	±1.0	N/A	N/A

## TEMPERATURE COEFFICIENT OF RESISTANCE (TCR)<sup>7</sup>

TCR Code (-55 °C to 125 °C)	Q	P	S	L
Absolute (ppm/°C)	±25	±50	±100	±200
Tracking (R1 Ref) (ppm/°C)	±5	±5	N/A	N/A

<sup>4</sup> Contact customer service for custom designs and features.

<sup>5</sup> JEDEC (Publication 95) Reference only.

<sup>6</sup> Consult factory for custom resistance values.

<sup>7</sup> Consult factory for custom tolerance values.

**BI Technologies Corporation**

4200 Bonita Place  
Fullerton, CA 92835 USA

Website: [www.bitechnologies.com](http://www.bitechnologies.com)

August 25, 2006

page 3 of 3

