



Model TK1 Side-Mounted Float Level Switch

DESCRIPTION

The TK1 liquid level switches are float-actuated devices designed for horizontal mounting in a tank or process vessel through threaded or flanged connections. This low-cost switch is ideal for OEM applications where a single point high or low level alarm is desired.

TECHNOLOGY

The TK1 achieves switching action through the use of a magnet attached to the float assembly and the magnet's interaction with a reed switch.

As the liquid level changes, the float and, therefore, the float magnet, moves. The proximity of the float magnet to the reed switch causes the switch to change state, making or breaking an electrical circuit.

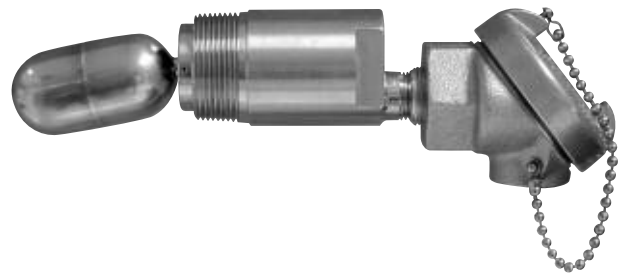

FEATURES

- Pressure ratings to 1500 psi (103 bar)
- Process temperature ratings to +300° F (149° C)
- Specific gravity as low as 0.40
- 1.5" or 2" process connections
- Compact design
- For use on rising or falling level
- Reliable reed switch action
- All stainless steel construction

APPLICATIONS

- Storage tanks
- Process vessels
- High or low level alarm
- Low level shut-down
- Overflow protection
- Explosion-proof installations
- Seal pots
- Skids
- OEM applications

PHYSICAL SPECIFICATIONS

Physical Range	Narrow differential, 0.50"
Minimum Specific Gravity	0.40
Float and Trim Material	316/316L stainless steel with 18-8 stainless steel pivot pin
Mounting Connection Material	316/316L stainless steel
Process Connections	1½" or 2" NPT or BSP threads 2" 150# or 300# ANSI flanges
Process Temperature Range	-40° to +300° F (-40° to +149° C)
Ambient Temperature Range	-40° to +160° F (-40° to +71° C)
Maximum Process Pressure	1500 psi (103 bar)

ELECTRICAL SPECIFICATIONS

Type of Contacts	SPST, SPDT or DPDT
Type of Switches	Hermetically sealed reed switch with optional four-wire dry contact relay
Switch Ratings	SPST, 100 VA, 240 VAC/VDC maximum, 1.0 A maximum switching current SPDT, 100W, 240 VAC/VDC maximum, 3.0 A maximum switching current 5 A @ 24 VDC hermetically sealed relay, 0.9W, 650 Ω resistance 5 A @ 120 VAC hermetically sealed relay, 1.2 VA
Enclosure Rating	TYPE 4X/7/9, Class I, Div. 1, Groups C & D
Enclosure Material	316/316L stainless steel or cast iron/aluminum
Electrical Connection	½" NPT or conduit box(es) with ¾" NPT
Contact Material	Silver cad-oxide

DIMENSIONAL SPECIFICATIONS

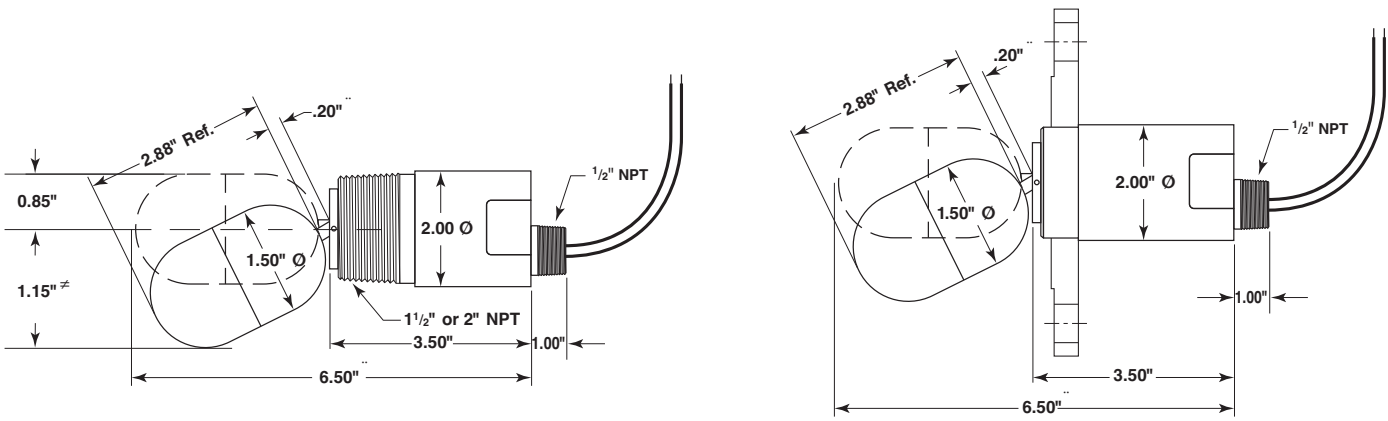

TK1 with threaded connection and SPST or SPDT switch with flying leads

TK1 with flanged connection and SPST or SPDT switch with flying leads

- ① Add 0.75" for models with extended stems
- ② Travel below center line is 1.44" for models with extended stems

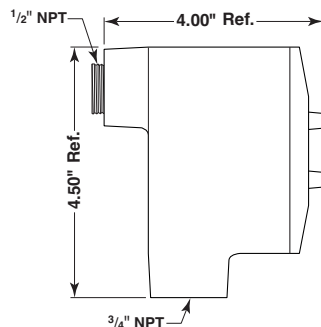

Junction box supplied with DPDT relay

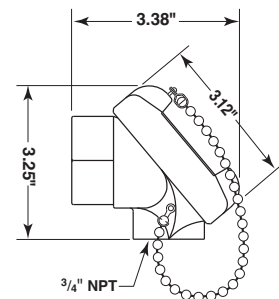

Junction box available with SPST or SPDT reed switch

MODEL NUMBER

TECHNOLOGY TYPE

TK	Side-mounted float level switch
----	---------------------------------

FLOAT

1	Narrow Differential, minimum s.g. 0.40, 316/316L stainless steel; maximum process pressure 1500 psi
---	---

FLOAT STEM

0	Standard length ①
1	Extended length ② (process connection size code 1 only)

- ① Use for 1½" nozzles to 0.71" long and 2" nozzles to 1.94" long
 ② Use for 1½" nozzles between 0.72" and 1.25" long

PROCESS CONNECTION SIZE

1	1.5" (process connection type code N & T only)
2	2" or 2" ANSI

PROCESS CONNECTION TYPE AND RATING

N	NPT
T	BSP-T tapered thread
A	150# ANSI RF flange (process connection size code 2 only)
B	300# ANSI RF flange (process connection size code 2 only)

CONNECTION MATERIAL

B	316/316L stainless steel
---	--------------------------

SWITCH TYPE

R	SPST reed switch, 100 VA
S	SPDT reed switch, 100W
D	Four-wire DPDT powered relay in junction box ③ 5 A @ 120 VAC (housing codes A & C only)
E	Four-wire DPDT powered relay in junction box ④ 5 A @ 24 VDC (housing codes A & C only)

- ③ This relay requires a 120 VAC power source to function.
 ④ This relay requires a 24 VDC power source to function.

HOUSING AND APPROVAL

J	316 SS, FM XP (switch types R & S only)
A	316 SS with cast iron/aluminum junction box, FM XP
K	316 SS, CSA XP (switch types R & S only)
C	316 SS with cast iron/aluminum junction box, CSA XP

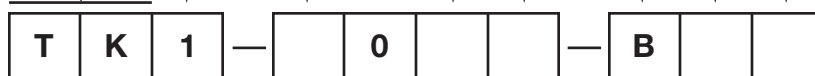

WARRANTY



All Magnetrol mechanical level and flow controls are warranted free of defects in materials or workmanship for five full years from the date of original factory shipment.

If returned within the warranty period; and, upon factory inspection of the control, the cause of the claim is determined to be covered under the warranty; then, Magnetrol will repair

or replace the control at no cost to the purchaser (or owner) other than transportation.

Magnetrol shall not be liable for misapplication, labor claims, direct or consequential damage or expense arising from the installation or use of equipment. There are no other warranties expressed or implied, except special written warranties covering some Magnetrol products.



5300 Belmont Road • Downers Grove, Illinois 60515-4499 • 630-969-4000 • Fax 630-969-9489 • www.magnetrol.com
145 Jardin Drive, Units 1 & 2 • Concord, Ontario Canada L4K 1X7 • 905-738-9600 • Fax 905-738-1306
Heikensstraat 6 • B 9240 Zele, Belgium • 052 45.11.11 • Fax 052 45.09.93
Regent Business Ctr., Jubilee Rd. • Burgess Hill, Sussex RH15 9TL U.K. • 01444-871313 • Fax 01444-871317

Copyright © 2010 Magnetrol International, Incorporated. All rights reserved. Printed in the USA.
Performance specifications are effective with date of issue and are subject to change without notice.
Magnetrol & Magnetrol logotype are registered trademarks of Magnetrol International.

BULLETIN: 44-108.5
EFFECTIVE: May 2010
SUPERCEDES: June 2007