



VGA Color CMOS Image Sensor Module

DATABRIEF

Features

- **Small physical size: integrated lens in a SmOP (Small Optical Package)**
- **640 x 480 VGA resolution**
- **Up to 30 frame/s VGA, 60 frame/s QVGA**
- **On-chip 10-bit ADC**
- **Automatic dark calibration**
- **2.6 V to 3.6 V power supply**
- **I²C communications**
- **Low power suspend mode**
- **4 or 5 wire nibble output**
- **Socket available separately**

Description

The VS6502 is a VGA resolution SmOP sensor module. SmOP technology combines the image sensor and fixed focus lens system in a single module. The SmOP sensor module is connected to the PCB either via a socket or flex option. The socket allows the PCB to use standard reflow soldering techniques.

The sensor outputs 10-bit raw digital image data which directly interface to a range of STMicroelectronics companion processors via 4/5 wire interface.

An I²C interface allows the processor to configure the device and control exposure and gain settings.

There are three different digital video output formats:

- VGA mode - 640 x 480 image size
- Sub-sampled QVGA mode - 320 x 240 image size
- Window Of Interest QVGA mode - 320 x 240 pixel

Applications

- Miniature USB web cameras (STV0676 - STV0674)
- Embedded cameras (STV0676 - STV0674): Handhelds, Cell phones, Network cameras
- Digital stills cameras (STV0674): Minicam, miniature USB flash drive cameras
- Digital video cameras (STV0674)

Technical Specifications

Pixel resolution	644 x 484 (VGA)
Pixel size	5.6 μm x 5.6 μm
Array size	3.6 mm x 2.7 mm
Dynamic range	> 52 dB
Analogue gain	0 to 24dB
Sensitivity (typical)	2.05 V / lux-s
Signal/Noise ratio	+ 37 dB
Supply voltage	2.6 to 3.6 V
Power consumption	Active (30 frame/s) < 30 mA
	Suspend (no clk) < 10 μA
Operating temperature	[-25 ; +70]°C
Package size	10.6 mm x 8.7 mm x 5.8 mm
Lens	47° HFOV, f#2.8
Package type	14 pad SmOP

Ordering information

Ordering code	Description
VS6502V015	VS6502 sensor module
XS0015/TR	socket for sensor module

DEVICE FUNCTIONALITY

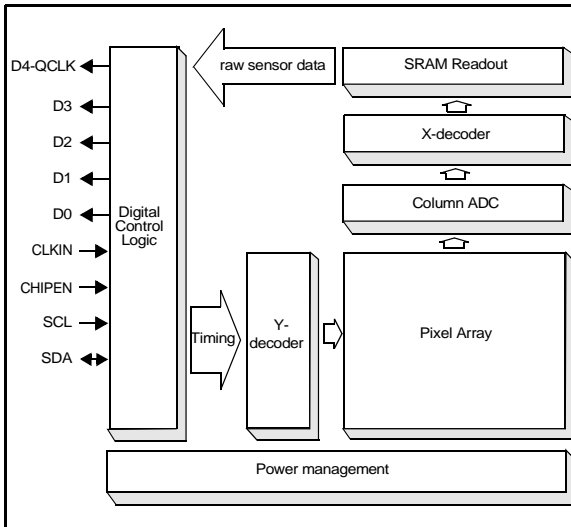

Network/Ethernet and/or USB camera

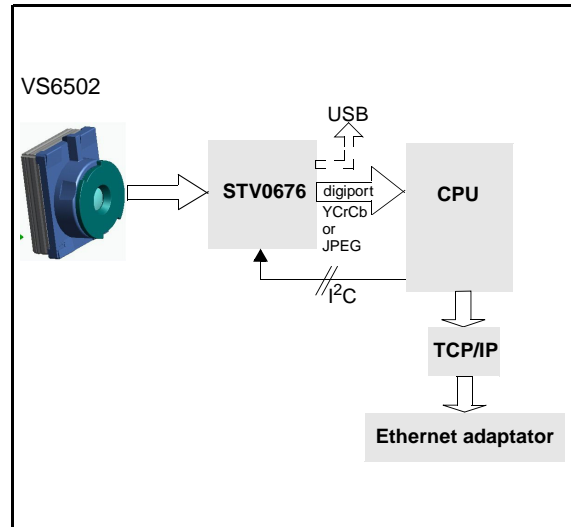

ORDERING DETAILS

VS6502V015	Sensor module only with socket option.
STV0681	Dual mode co-processor (no internal FLASH)
STV0676	PC camera co-processor
STV0674T100	Multi-mode co-processor
STV-6502S-D01	Plug-in daughtercard for VS6502
STV-674/100T-E01	EVK for STV0674
STV-681-E01	EVK for STV0681
STV-676-E01	EVK for STV0676

Miniature VGA DSC solution

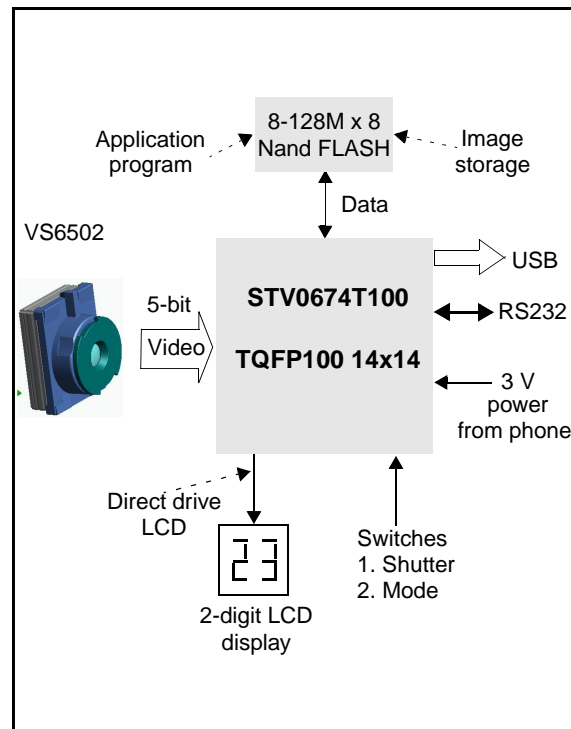

No 'sensor only' EVK available for the VS6502

Information furnished is believed to be accurate and reliable. However, STMicroelectronics assumes no responsibility for the consequences of use of such information nor for any infringement of patents or other rights of third parties which may result from its use. No license is granted by implication or otherwise under any patent or patent rights of STMicroelectronics. Specifications mentioned in this publication are subject to change without notice. This publication supersedes and replaces all information previously supplied. STMicroelectronics products are not authorized for use as critical components in life support devices or systems without the express written approval of STMicroelectronics.

The ST logo is a registered trademark of STMicroelectronics.

© 2004 STMicroelectronics. All Rights Reserved.

<http://www.st.com>

