



DTR-1250-MM

1x9 Gigabit Ethernet 850 nm VCSEL Transceivers



Features

- ☑ Compliant with IEEE 802.3z Draft D5.0 1000BASE-SX specifications for Gigabit Ethernet
- ☑ 275 m distance with 62.5 μm multimode fiber
- ☑ 550 m distance with 50 μm multimode fiber
- ☑ Eye Safe (Class I Laser Safety)
- ☑ Excellent EMI & ESD protection (optional extra EMI shield also available)
- ☑ Multi-sourced 1x9 package with Duplex SC interface (ST or FC connector also available)
- ☑ PCI-mezzanine-compliant package (9.8 mm maximum height)
- ☑ Single +5 V supply & PECL interface (AC coupling option also available)
- ☑ Conductive Plastic or Metal package
- ☑ Wave Solder Process Compatible

Description

The DTR-1250-MM fiber optic transceiver offers a simple and convenient way to interface 1000BASE-SX Gigabit Ethernet boards running at 1.25 Gbaud to multimode fiber optic cables. A high reliability 850 nm wavelength Vertical Cavity Surface Emitting Laser (VCSEL) is used in the transmitter. All modules satisfy Class I Laser Safety requirements in accordance with the US FDA/CDRH and international IEC-825 standards.

The transceiver is housed in a PCI-mezzanine-compliant (9.8 mm maximum height) one-row, 9-pin (1x9) package with Duplex SC connector interface. The transceiver package is made of *conductive* plastic to obtain excellent EMI shielding. Optional EMI shields for making direct contact from the SC

connector to the equipment chassis opening are also available. The transceiver is also offered in a metal package with ST or FC connector interface.

The transmitter and receiver DATA interface are differential direct-coupled Pseudo Emitter Coupled Logic (PECL). An alternate version with AC coupling interface is also available. The receiver Signal Detect output interface is direct-coupled Pseudo Emitter Coupled Logic (PECL).

The transceiver operates from a single +5V power supply over an operating temperature range of 0°C to +70°C. A low power consumption version with 3.3 V supply voltage is also offered. Please refer to the DTR-1250-3.3-MM data sheet.

Absolute Maximum Ratings

Parameter	Symbol	Minimum	Maximum	Units
Storage Temperature	T_{st}	- 40	+ 85	°C
Operating Temperature	T_{op}	0	+ 70	°C
Supply Voltage	V_{CC}	- 0.5	+ 6.0	V
Input Voltage	V_{in}	- 0.5	V_{CC}	V
Output Current	I_O	-	50	mA
Lead Soldering Temperature & Time	-	-	260°C, 10 sec	

Optical Communication Products, Inc.

DTR-1250-MM

Transmitter Electrical Interface (over Operating Temperature, $V_{CC} = 4.75$ to $5.25V$)

Parameter	Symbol	Minimum	Typical	Maximum	Units
Input HIGH Voltage ¹	V_{IH}	$V_{CC} - 1.165$	-	$V_{CC} - 0.700$	V
Input LOW Voltage ¹	V_{IL}	$V_{CC} - 1.890$	-	$V_{CC} - 1.475$	V
Data Input Current - HIGH	I_H	-	-	350	μA
Data Input Current - LOW	I_L	-	-	250	μA

¹ For AC-coupled modules, the input voltage swing is 0.3 V minimum and 1.2 V maximum.

Receiver Electrical Interface (over Operating Temperature, $V_{CC} = 4.75$ to $5.25V$)

Parameter	Symbol	Minimum	Typical	Maximum	Units
Output HIGH Voltage ¹	V_{OH}	$V_{CC} - 1.035$	-	$V_{CC} - 0.700$	V
Output LOW Voltage ¹	V_{OL}	$V_{CC} - 1.950$	-	$V_{CC} - 1.595$	V
Output Current	I_O	-	-	25	mA

¹ For AC-coupled modules, the output voltage swing into 50-ohm load is 0.3 V minimum and 1 V maximum.

Electrical Power Supply Characteristics (over Operating Temperature, $V_{CC} = 4.75$ to $5.25V$)

Parameter	Symbol	Minimum	Typical	Maximum	Units
Supply Voltage	V_{CC}	4.75	5.0	5.25	V
Supply Current	DC-coupled module	I_{CC}	-	140	mA
	AC-coupled module	I_{CC}	-	160	mA

Application Notes

DATA interface (DC-coupled module): The interface circuit for the standard DC-coupled module with direct-coupled PECL interface is shown in Figure 1. The termination resistors for the transmitter should be close to the DTR transceiver module. The termination resistors for the receiver (50 ohms to $V_{CC} - 2$ volts or the Thevenin equivalent resistors shown) should be close to the PHY or SERDES IC (which receives the DATA outputs from the receiver).

When interfacing with 3.3 V SERDES IC, AC coupling can be used as shown in Figure 2. The termination resistors required by the SERDES are not shown in this figure.

DATA interface (AC-coupled module): For modules with AC coupling option, both transmitter and receiver interface has internal bias, termination and AC coupling capacitor. The transmitter can be connected directly to the driving SERDES. The receiver can be connected directly to the external 50 ohm load (termination resistor of the SERDES).

SIGNAL DETECT: The Signal Detect circuit monitors the level of the incoming optical signal and generates a logic LOW signal when insufficient photocurrent is produced. The SIGNAL DETECT output is PECL level requiring termination (510 ohms to GND is recommended).

Power supply and grounding: The power supply line should be well-filtered. All 0.1 μF power supply bypass capacitors should be as close to the DTR transceiver module as possible. The two front GND posts should be grounded to Circuit Ground or Chassis Ground.

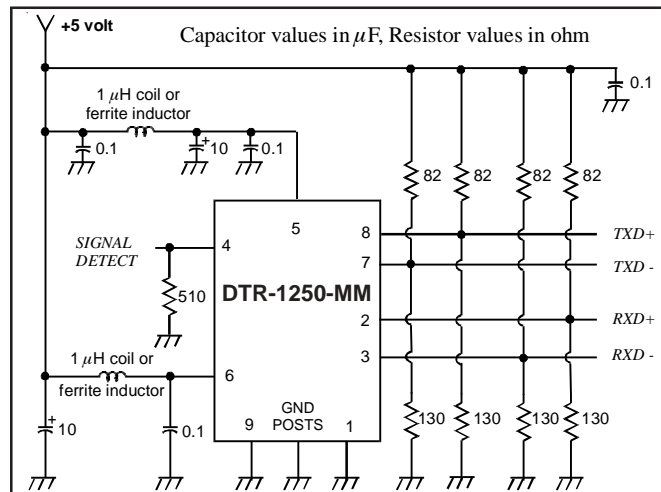

Fig.1 Interfacing DC-coupled module to direct-PECL signals

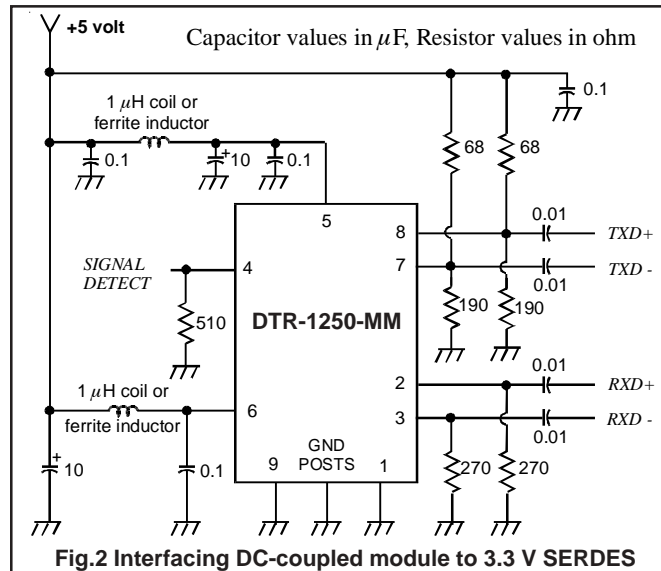

Fig.2 Interfacing DC-coupled module to 3.3 V SERDES

DTR-1250-MM

Transmitter Performance Characteristics (over Operating Temperature, $V_{CC} = 4.75$ to $5.25V$)

All parameters guaranteed only at typical data rate

Parameter	Symbol	Minimum	Typical	Maximum	Units
Operating Data Rate ¹	B	-	1250	-	Mb/s
Optical Output Power ²	P_o	- 9.5	- 7	- 4	dBm
Center Wavelength	λ_c	820	-	860	nm
Spectral Width (RMS)	$\Delta\lambda_{RMS}$	-	-	0.85	nm
Extinction Ratio	P_{hi}/P_{lo}	9	-	-	dB
Deterministic Jitter	DJ	-	-	80	ps
Random Jitter	RJ	-	-	147	ps
Relative Intensity Noise	RIN	-	-	- 117	dB/Hz
Coupled Power Ratio	CPR	9	-	-	dB
Transmitter Output Eye	compliant with Eye Mask Defined in 802.3z standard				

¹ Data rate ranges from 125 Mb/s to 1300 Mb/s. However some degradation may be incurred in overall performance.
² Measured average power coupled into either 50 μm or 62.5 μm multimode fiber (MMF).

Receiver Performance Characteristics (over Operating Temperature, $V_{CC} = 4.75$ to $5.25V$)

All parameters guaranteed only at typical data rate

Parameter	Symbol	Minimum	Typical	Maximum	Units
Operating Data Rate ¹	B	-	1250	-	Mb/s
Minimum Input Optical Power (10^{-12} BER) ²	P_{min}	- 17.0	-	-	dBm
Maximum Input Optical Power (10^{-12} BER) ²	P_{max}	- 3.0	-	-	dBm
Signal Detect Thresholds	Increasing Light Input	P_{sd+}	-	-	- 17.0
	Decreasing Light Input	P_{sd-}	- 30.0	-	-
Signal Detect Hysteresis	-	0.5	-	-	dB
Deterministic Jitter	DJ	-	-	170	ps
Random Jitter	RJ	-	-	96	ps
Wavelength of Operation	λ	770	-	860	nm
Return Loss	-	12	-	-	dB
Electrical 3 dB upper cutoff frequency	-	-	-	1500	MHz
Stressed Receiver Sensitivity	compliant with 802.3z standard				

¹ Data rate ranges from 125 Mb/s to 1300 Mb/s. However some degradation may be incurred in overall performance.
² When measured with 2⁷-1 for Fast Ethernet, Gigabit Ethernet, Fiber Channel, FDDI, ESCON and 2²³-1 for SONET/ATM/SDH data rates (OC3-OC12, OC-24).

Pin Assignments

Optical Communication Products, Inc.
 DATE OF MANUFACTURE:

 MANUFACTURED IN THE USA
 This product complies with
 21 CFR 1040.10 and 1040.11
Meets Class I Laser Safety Requirements

Laser Safety: All transceivers are Class I Laser products per FDA/CDRH and IEC-825 standards. They must be operated under specified operating conditions.

PIN	FUNCTION
1	RX GND
2	RD+ (RX DATA OUT +)
3	RD- (RX DATA OUT -)
4	SD (RX SIGNAL DETECT)
5	V_{CCRX}
6	V_{CCTX}
7	TD- (TX DATA IN -)
8	TD+ (TX DATA IN +)
9	TX GND

DTR-1250-MM

ST Receptacle Package *(Refer to DTR-1250-SM data sheet for FC Receptacle Package Drawing)*

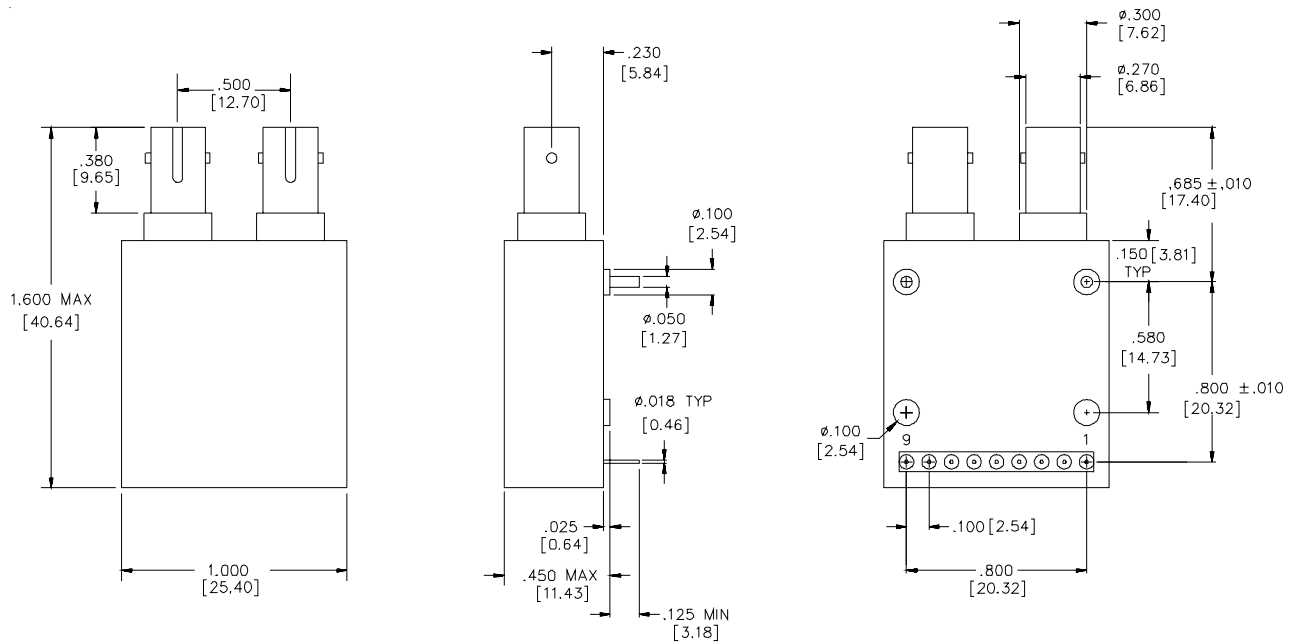

Default tolerances for all dimensions given in inches (Unless otherwise noted) .XXX = +/- .005 , .XX = +/- .01

Dimensions in inches [mm]

Duplex SC Receptacle Package with SH Shield (with notch)

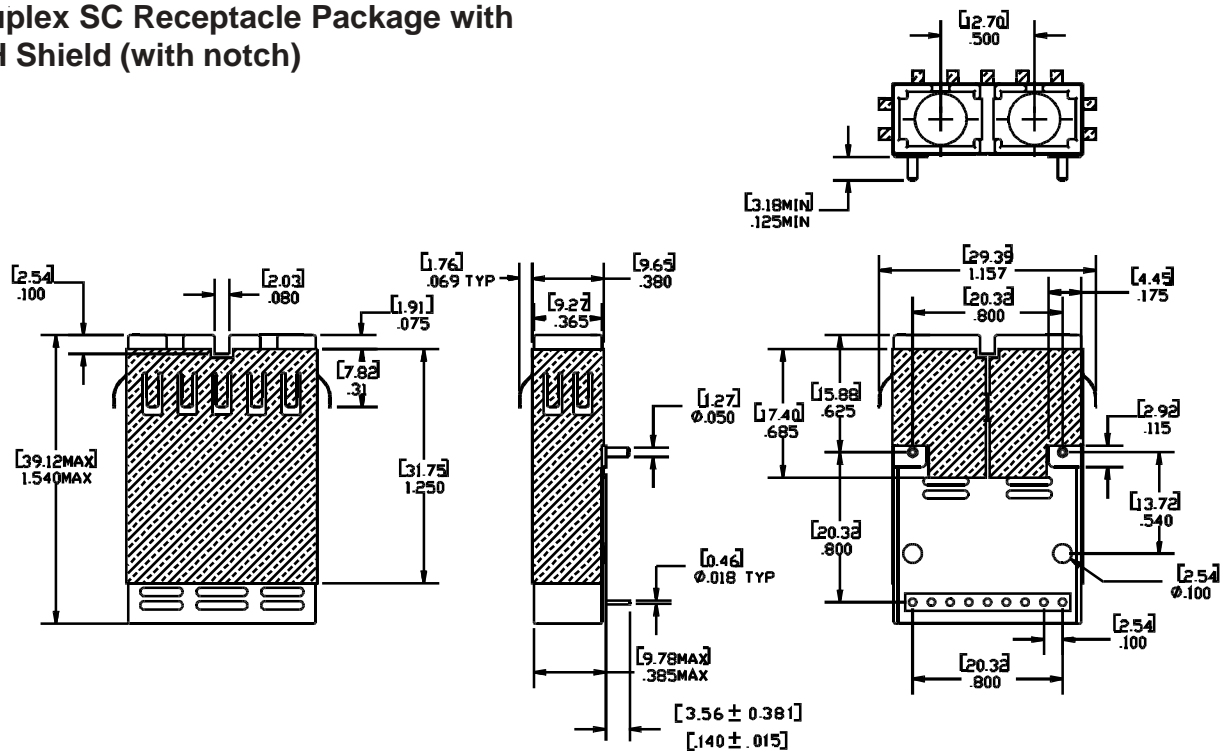

Default tolerances for all dimensions given in inches (Unless otherwise noted) .XXX = +/- .005 , .XX = +/- .01

Dimensions in inches [mm]

DTR-1250-MM

Duplex SC Receptacle Package without EMI Shield

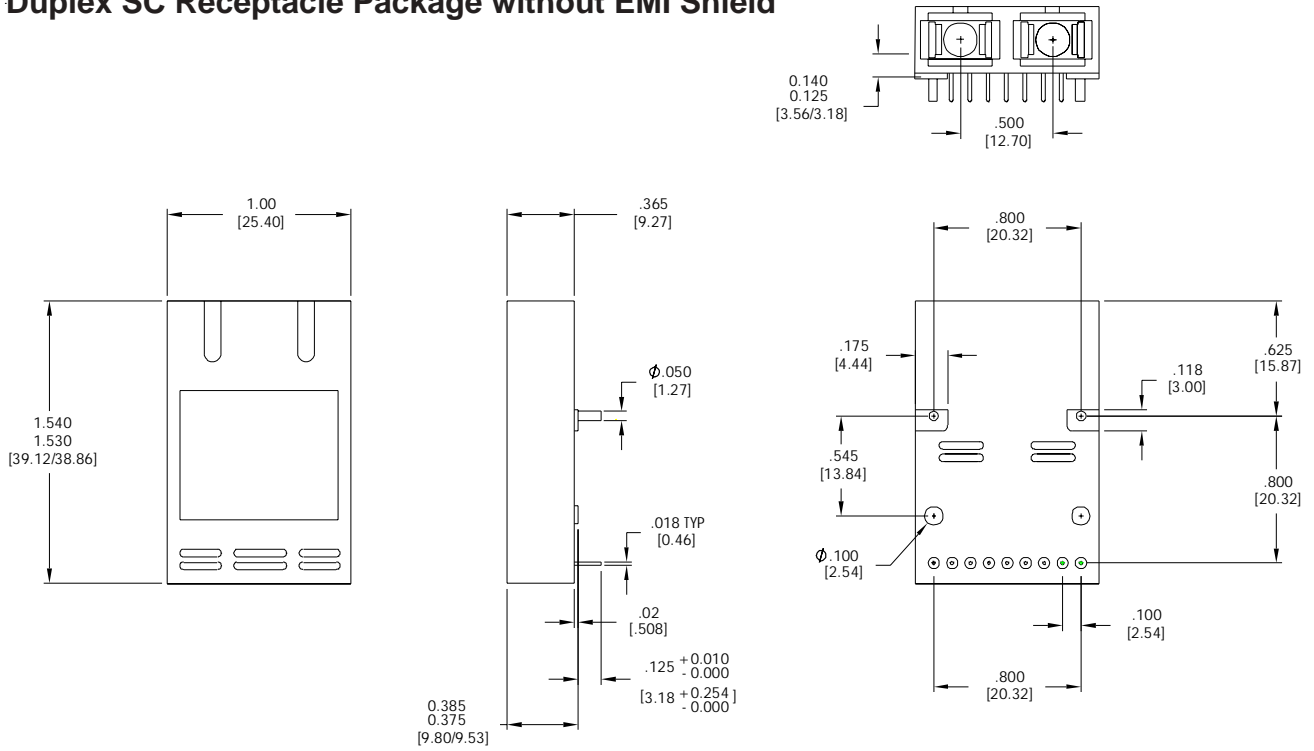

Default tolerances for all dimensions given in inches (Unless otherwise noted) .XXX = +/- .005 , .XX = +/- .01

Dimensions in inches [mm]

Duplex SC Receptacle Package with ES Shield (without notch)

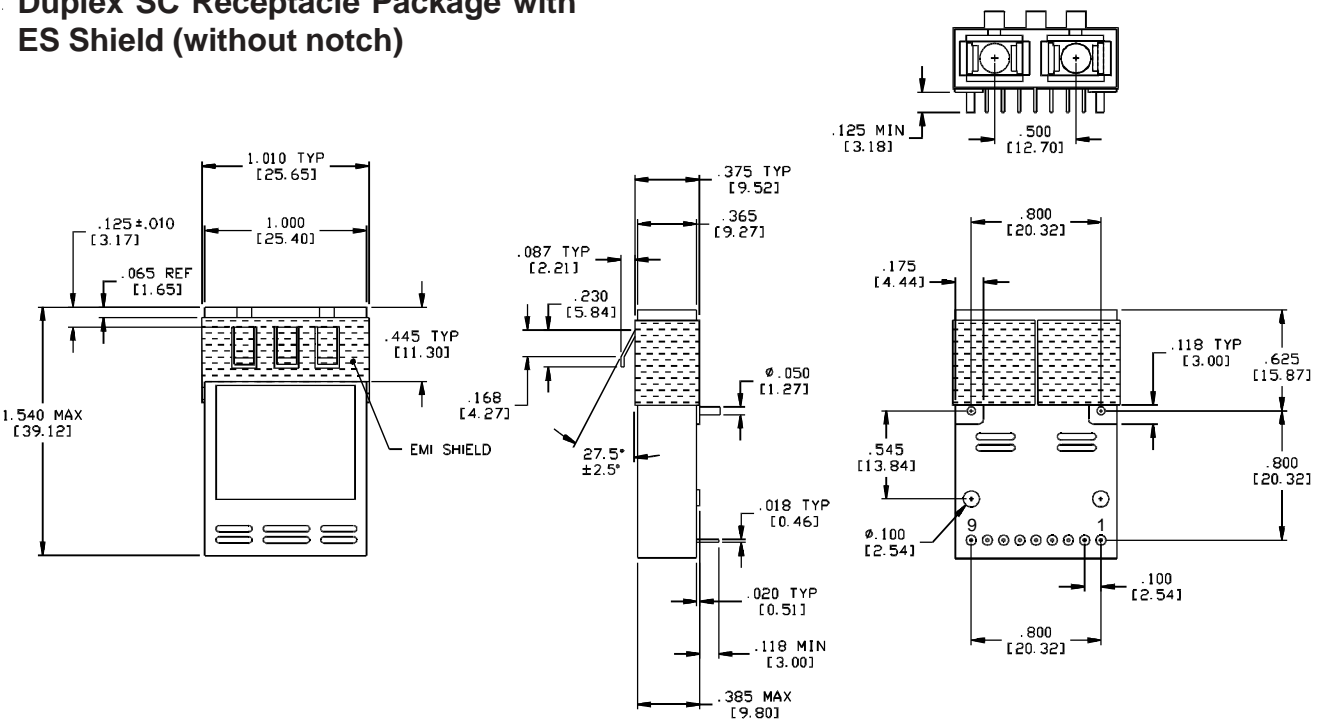

Default tolerances for all dimensions given in inches (Unless otherwise noted) .XXX = +/- .005 , .XX = +/- .01

Dimensions in inches [mm]

DTR-1250-MM

Ordering Information for SC (without EMI shield), ST and FC modules

Module Name	Connector	Coupling	Module Name	Connector	Coupling
DTR-1250-MM	SC	DC	DTR-1250-MM-SA	ST	AC
DTR-1250-MM-AC	SC	AC	DTR-1250-MM-FC	FC	DC
DTR-1250-MM-ST	ST	DC	DTR-1250-MM-FA	FC	AC

Ordering Information for SC modules (with EMI shield)

Module Name	EMI Shield	Coupling
DTR-1250-MM-ES	ES (without notch)	DC
DTR-1250-MM-AE	ES (without notch)	AC
DTR-1250-MM-SH	SH (with notch)	DC
DTR-1250-MM-SH-AC	SH (with notch)	AC

Optical Communication Products, Inc.

20961 Knapp Street, Chatsworth, CA 91311, Tel.: 818-701-0164, FAX: 818-701-1468, <http://www.ocp-inc.com>

Optical Communication Products, Inc. reserves the right to make changes in equipment design or specifications without notice. Information supplied by Optical Communication Products, Inc. is believed to be accurate and reliable. However, no responsibility is assumed by Optical Communication Products, Inc. for its use nor for any infringements of third parties which may result from its use. No license is granted by implication or otherwise under any patent right of Optical Communication Products, Inc.