



POWERTIP TECH. CORP.

SPECIFICATIONS

CUSTOMER	: PTC
SAMPLE CODE (Ver.)	: PS320240T-004-I-02 (Ver.0)
MASS PRODUCTION CODE (Ver.)	: PH320240T-004-IC1Q (Ver.0)
DRAWING NO. (Ver.)	: PH-06005-004(Ver.0)

Customer Approved

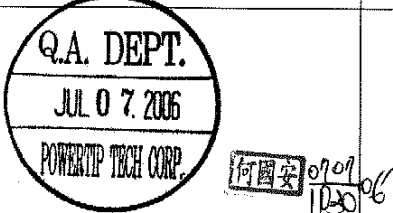
Date:

Approved	QC Confirmed	Designer
		

Approval For Specifications Only.

* This specification is subject to change without notice.

Please contact Powertip or it's representative before designing your product based on this specification.

Approval For Specifications and Sample.

POWERTIP TECH. CORP.

Headquarters:

No.8, 6th Road, Taichung Industrial Park,

Taichung, Taiwan

台中市 407 工業區六路 8 號

TEL: 886-4-2355-8168

FAX: 886-4-2355-8166

E-mail: sales@powertip.com.tw

[Http://www.powertip.com.tw](http://www.powertip.com.tw)

NO.PT-A-005-7

History of Version

Date	Ver.	Description	Page	Design by
2006/7/5	0	Mass Production	-	Danny

Total : 25 Page

Contents

1. SPECIFICATIONS

- 1.1 Features
- 1.2 Mechanical Specifications
- 1.3 Absolute Maximum Ratings
- 1.4 DC Electrical Characteristics
- 1.5 Optical Characteristics

2. MODULE STRUCTURE

- 2.1 Counter Drawing
- 2.2 Interface Pin Description
- 2.3 Timing Characteristics

3. QUALITY ASSURANCE SYSTEM

- 3.1 Quality Assurance Flow Chart
- 3.2 Inspection Specification

4. RELIABILITY TEST

- 4.1 Reliability Test Condition

5. PRECAUTION RELATING PRODUCT HANDLING

- 5.1 Safety
- 5.2 Handling
- 5.3 Storage
- 5.4 Terms of Warranty

6. Packaging

Appendix A: LCM Drawing

Appendix B: Package

Note : For detailed information please refer to IC data sheet :

Primacy(TFT LCD) : HX8218 + HX8615

1. SPECIFICATIONS

1.1 Features

LCM

Item	Standard Value
Display Type	320(R · G · B) * 240 Dots
LCD Type	Normally white , Transmissive type
Screen size(inch)	3.5 inch
Viewing Direction	6 O'clock
Color configuration	RGB-Strip
Backlight Type	LED
Interface	Digital 24-bits RGB
Driver IC	HX8218 + HX8615
Item	Standard Value
ROHS	THIS PRODUCT CONFORMS THE ROHS OF PTC Detail information please refer web side : http://www.powertip.com.tw/news/LatestNews.asp

LCM Weight : 40 g

1.2 Mechanical Specifications

Item	Standard Value	Unit
Outline Dimension	76.9(W) * 63.9 (L) * 3.4 (H)(Max)	mm

LCM

Item	Standard Value	Unit
Active Area	70.08 (W) * 52.56 (L)	mm
Dot Pitch	0.219 (W) * 0.219 (L)	mm

Note : For detailed information please refer to LCM drawing

1.3 Absolute Maximum Ratings

Module

Item	Symbol	Condition	Min.	Max.	Unit
System Power Supply Voltage	VDD	AVSS=0	-0.3	7.0	V
	VCC	GND=0	-0.3	7.0	
	VGH	GND=0	-0.3	32.0	
	VGL	GND=0	-22.0	0.3	
	VGH-VGL	GND=0	-0.3	45.0	
Input Voltage	V _i	-	-0.3	VDD+0.3	V
	V _I	-	-0.3	VCC+0.3	V
Operating Temperature	T _{OP}	Excluded B/L	-20	70	°C
Storage Temperature	T _{ST}	Excluded B/L	-30	80	°C

1.4 DC Electrical Characteristics

Module

Gnd = 0V , Ta = 25°C

Item	Symbol	Condition	Min.	Typ.	Max.	Unit
Digital Supply Voltage	VCC	-	3	3.3	3.6	V
Digital Operation Current	ICC	-	-	1.8	2.7	mA
Analog Supply Voltage	VDD	-	3.8	5	5.5	V
Analog Operation Current	IDD	-	-	5.8	8.7	mA
Frame frequency	fFrame	-	-	60	90	Hz
Dot Data Clock	DCLK	-	-	-	6.4	MHz

1.5 Optical Characteristics

TFT LCD panel

Item		Symbol	Condition	Min.	Typ.	Max.	unit	
Response time	Rise	Tr	Ta = 25°C θX, θY = 0°	-	15	30	ms	Note2
	Fall	Tf		-	35	50		
Color of CIE Coordinate*1	White	X		0.27	0.32	0.37	-	-
		Y		0.29	0.34	0.39		
	Red	X		0.51	0.56	0.61		
		Y		0.30	0.35	0.40		
	Green	X		0.29	0.34	0.39		
		Y		0.54	0.59	0.64		
	Blue	X		0.10	0.15	0.20		
		Y		0.08	0.13	0.18		
Viewing angle	Top	θY+	CR ≥ 10	45	-	-	deg.	Note1
	Bottm	θY-		50	-	-		
	Left	θX-		50	-	-		
	Right	θX+		50	-	-		
Contrast ratio		CR	Ta = 25°C	-	180	220	-	Note3

Note 1.

Optical characteristics-2

Viewing angle

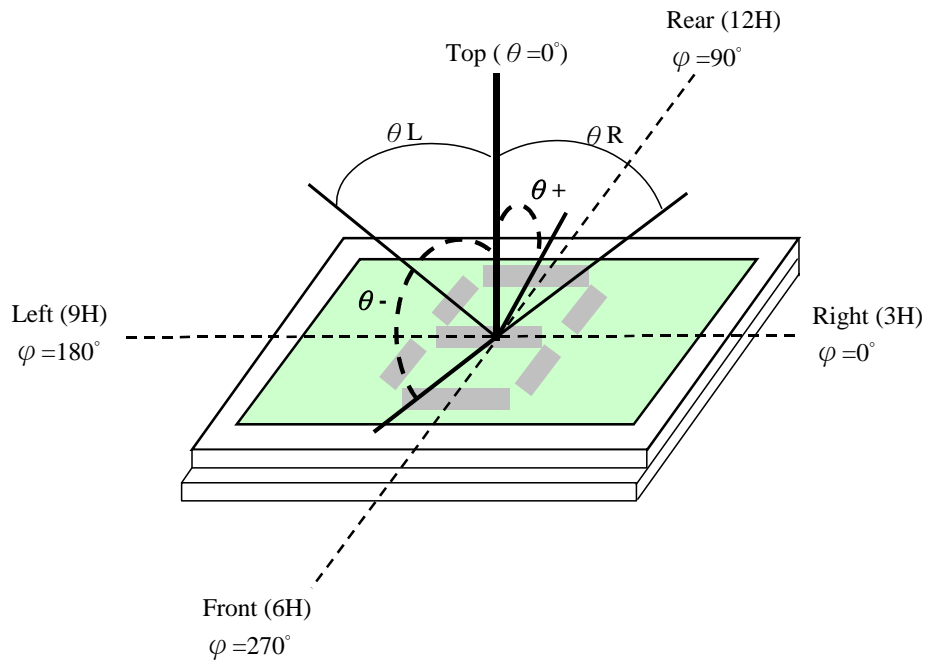

Viewing angle

Note 2.

Optical characteristics-3

Fig.2 Definition of response time

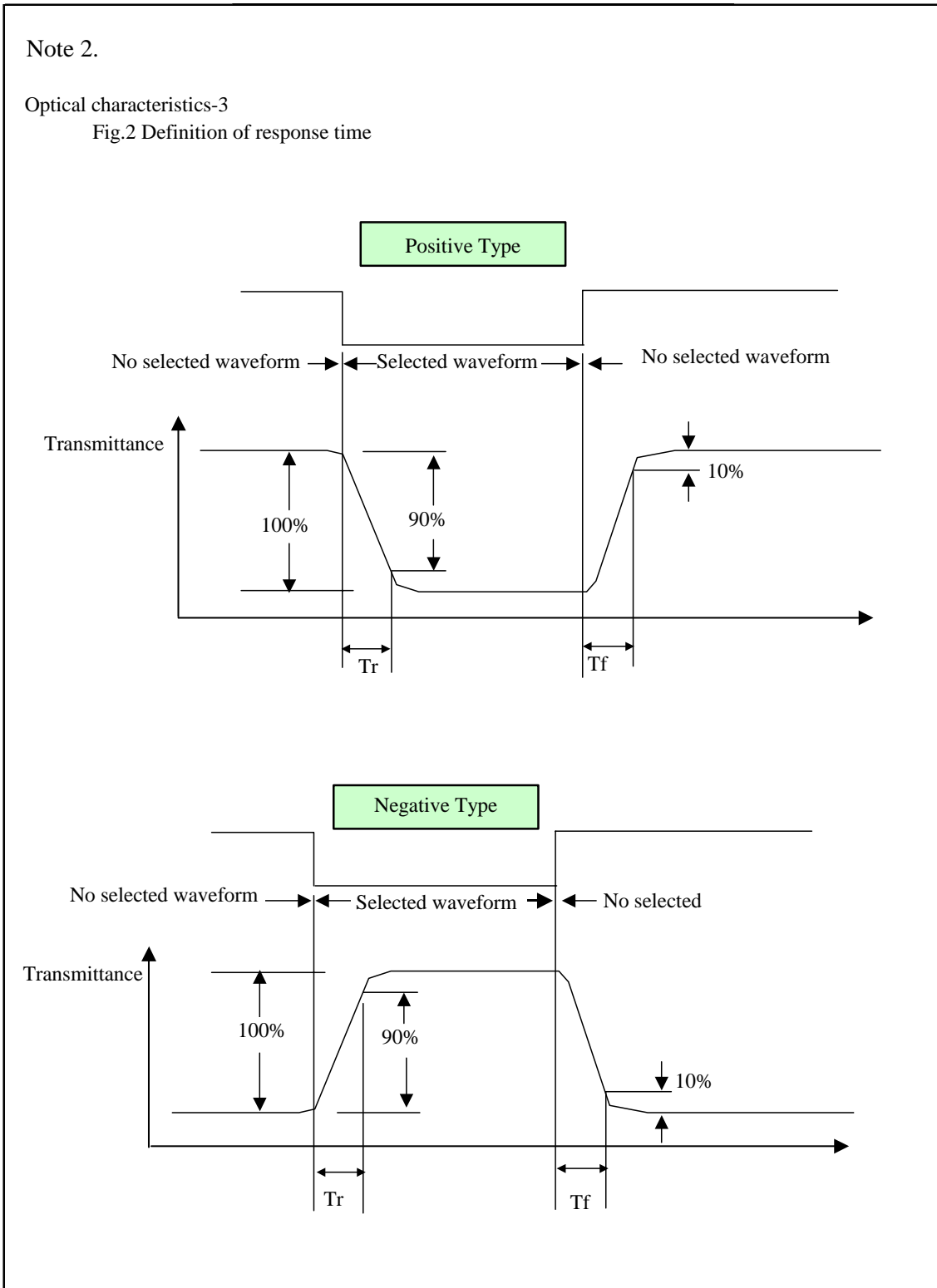

Electrical characteristics-2

2 Drive waveform

V_{op} : Drive voltage f_F : Frame frequency
 $1/B$: Bias f_D : Drive frequency
 N : Duty

(1) Selected waveform

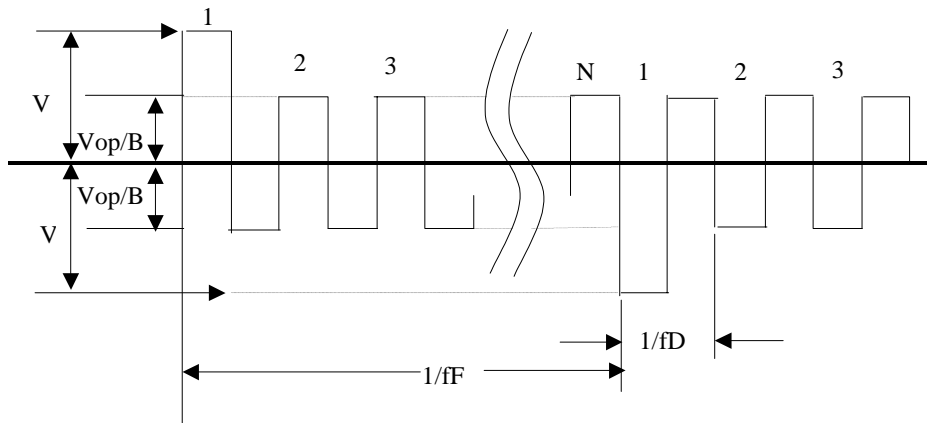

(2) Non- Selected waveform

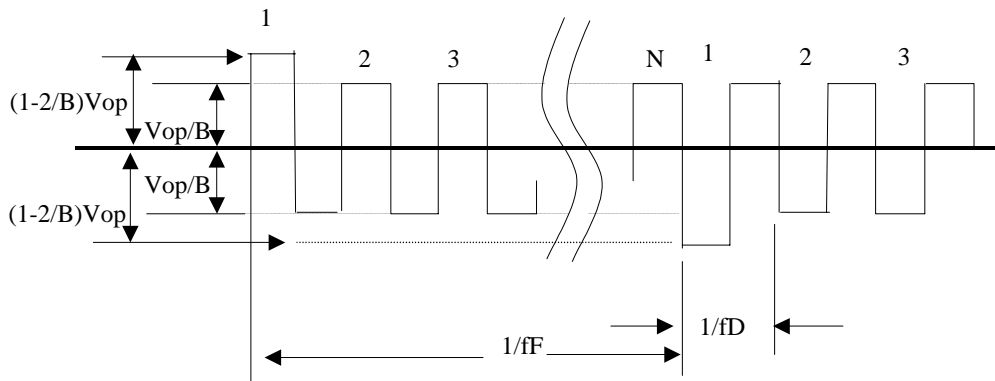

Note:

Frame frequency is defined as follows: Common side supply voltage peak - to - peak / 2 = 1 period

Note 3. : Definition of Vth

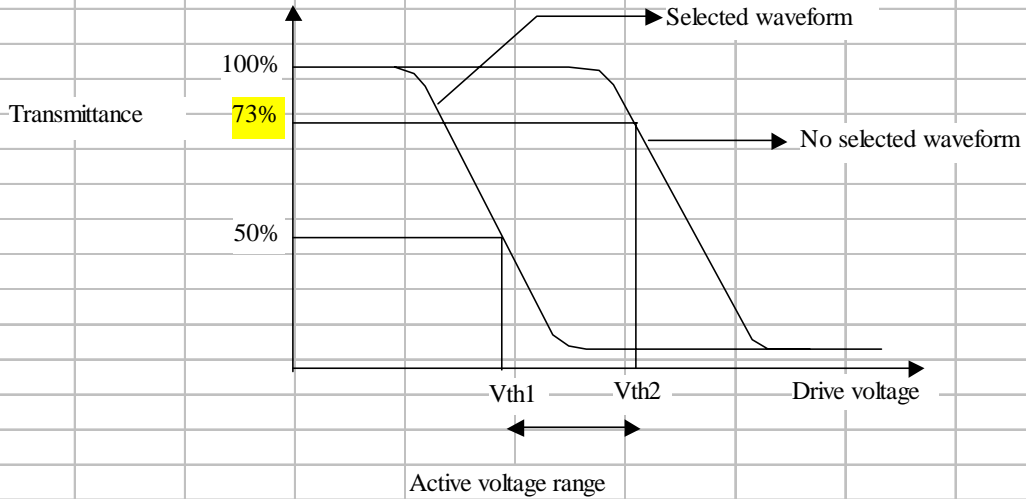

	Vth1	Vth2
View direction	10°	40°
Drive waveform	(Selected waveform)	(No selected waveform)
Transmittance	50%	73%

※1 Contrast ratio

$$= (\text{Brightness in OFF state}) / (\text{Brightness in ON state})$$

Outline of Electro-Optical Characteristics Measuring System

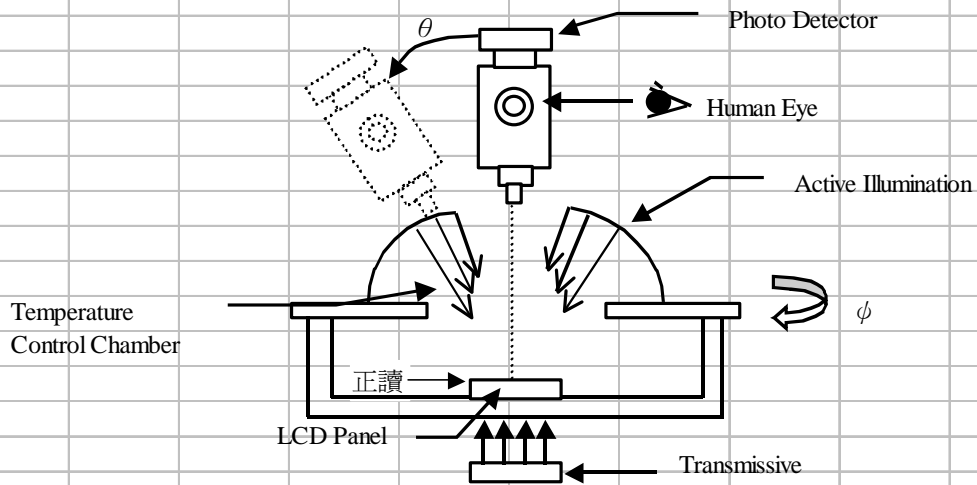

1.6 Backlight Characteristics

LCD Module with LED Backlight

Maximum Ratings

Item	Symbol	Conditions	Min.	Typ	Max.	Unit
Forward Current	I_F	$T_a = 25^\circ\text{C}$	-	20	-	mA
Reverse Voltage	V_R	$T_a = 25^\circ\text{C}$	-	-	-	V
Power Dissipation	P_D	$T_a = 25^\circ\text{C}$	-	420	-	mW

Electrical / Optical Characteristics

Item	Symbol	Conditions	Min.	Typ.	Max.	Unit
Average Brightness (with LCD)	I_v	IF=20 mA	200	290	-	cd/m ²
CIE Color Coordinate (With LCD)	X	IF= 20 mA	0.29	0.32	0.35	-
	Y		0.31	0.34	0.37	
Backlight Uniformity (with LCD)	ΔB	IF= 20mA	70	-	-	%
Color	White					

Note: $\Delta B = (\text{Min}/\text{Max})100\%$

2. MODULE STRUCTURE

2.1 Counter Drawing

2.1.1 LCM Mechanical Diagram

* See Appendix

2.1.2 Block Diagram

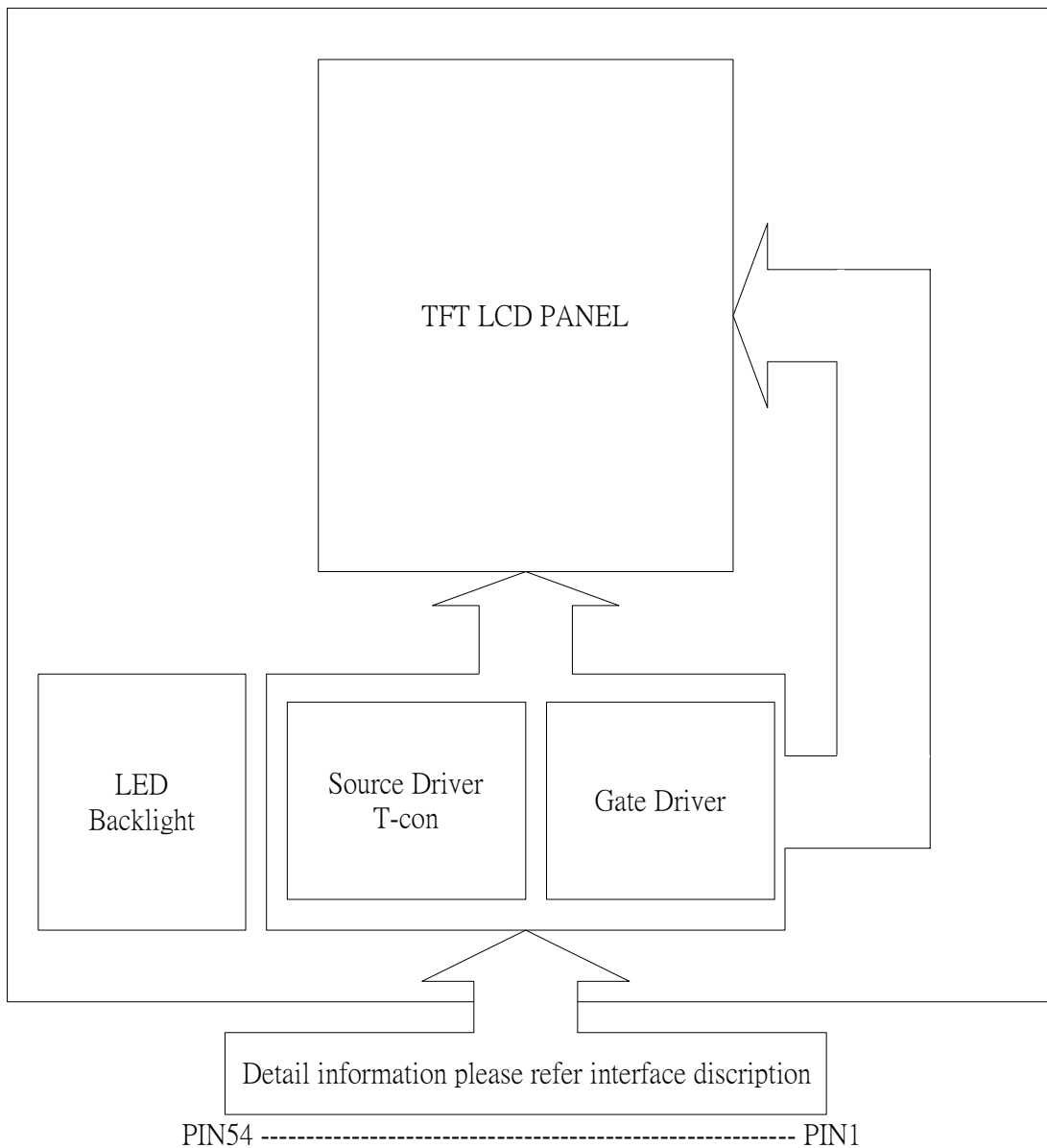

2.2 Interface Pin Description

Pin No.	Symbol	Function
1	VBL-	Power supply for LED Backlight cathode input
2	VBL-	Power supply for LED Backlight cathode input
3	VBL+	Power supply for LED Backlight anode input
4	VBL+	Power supply for LED Backlight anode input
5	NC	Not used , Must be open
6	NC	Not used , Must be open
7	POL	Connect to Vcom circuit
8	/RESET	Hardware reset
9	SPENA	Serial port data enable signal
10	SPCLK	Serial data clock
11	SPDAT	Serial data
12	B0	Blue data bit 0
13	B1	Blue data bit 1
14	B2	Blue data bit 2
15	B3	Blue data bit 3
16	B4	Blue data bit 4
17	B5	Blue data bit 5
18	B6	Blue data bit 6
19	B7	Blue data bit 7
20	G0	Green data bit 0
21	G1	Green data bit 1
22	G2	Green data bit 2
23	G3	Green data bit 3
24	G4	Green data bit 4
25	G5	Green data bit 5
26	G6	Green data bit 6
27	G7	Green data bit 7
28	R0	Red data bit 0
29	R1	Red data bit 1
30	R2	Red data bit 2
31	R3	Red data bit 3

32	R4	Red data bit 4
33	R5	Red data bit 5
34	R6	Red data bit 6
35	R7	Red data bit 7
36	HSYNC	Horizontal sync input
37	VSYNC	Vertical sync input
38	DCLK	Dot data clock
39	V _{DD}	Analog power
40	V _{DD}	Analog power
41	V _{CC}	Digital power
42	V _{CC}	Digital power
43	NC	Not used , Must be open
44	NC	Not used , Must be open
45	V _{GL}	Gate off power
46	NC	Not used , Must be open
47	V _{GH}	Gate on power
48	NC	Not used , Must be open
49	NC	Not used , Must be open
50	NC	Not used , Must be open
51	VCOM	Driving input
52	ENB	Data enable control
53	GND	Ground
54	VSS	Ground

2.3 Timing Characteristics

Signal	Item	Symbol	Min.	Typ.	Max.	Unit	
Dclk	Frequency	Dclk		6.4		MHz	
	High Time	Tch		78		ns	
	Low Time	Tcl		78		ns	
Data	Setup Time	Tds	12			ns	
	Hold Time	Tdh	12			ns	
Hsync	Period	TH		408		DCLK	
	Pulse Width	Thp		30		DCLK	
	Back-Porch	Thb		38		DCLK	
	Display Period	Thd		320		DCLK	
	Front-Porch	Thf		20		DCLK	
Vsync	Period	NTSC	Tv	262.5		TH	
		PAL		312.5			
	Pulse Width		Tvp	1	3	5	TH
	Back-Porch	NTSC	Tvb	15		TH	
		PAL		23			
	Display Period		Tvd		240		TH
	Front-Porch	NTSC	Tvf	4.5		TH	
		PAL		46.5			

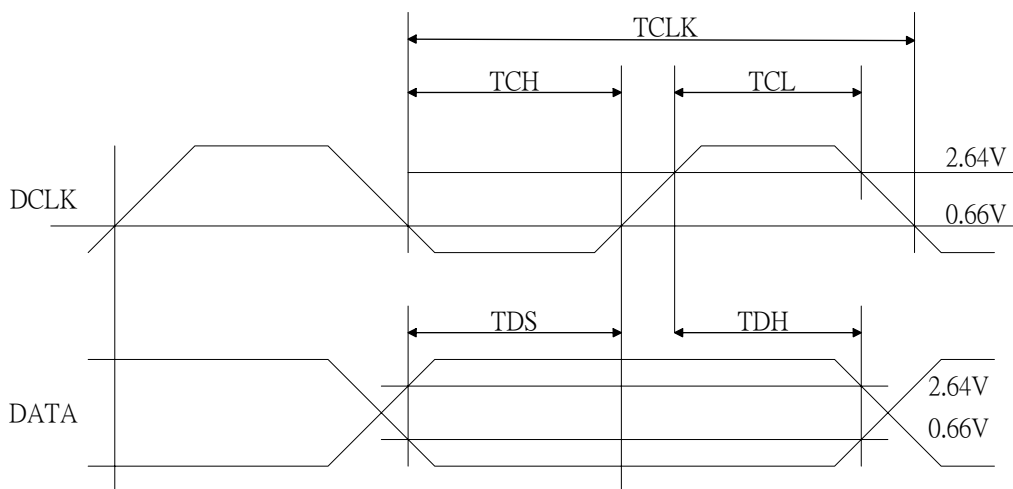

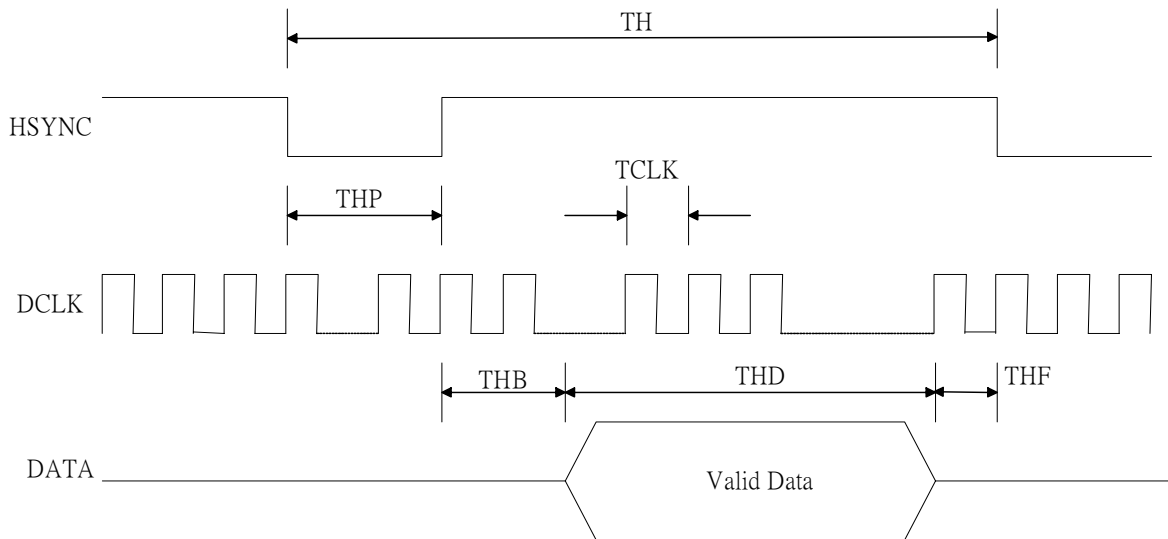
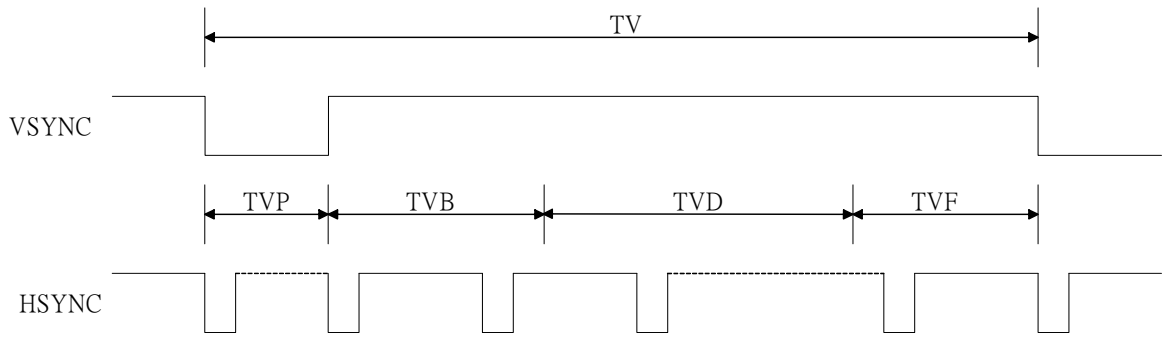
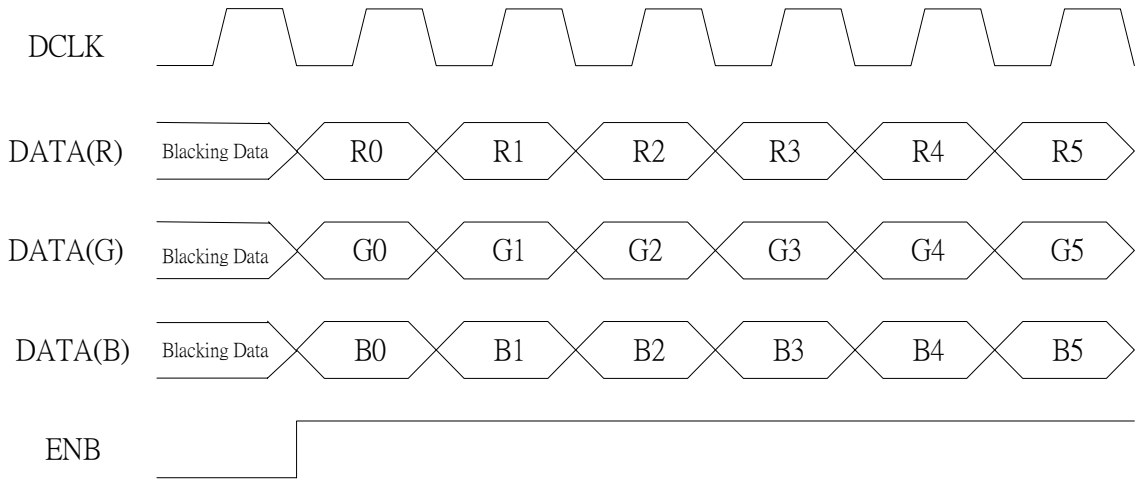

2.4 Power Sequence

The LCD panel adopts high voltage driver ICs , so it could be permanently damaged if a wrong power on/off sequence is used, When powering on the LCD , VCC should go up firstly, and then turn on VGL and VDD , and finally VGH ,Turn off the LCD panel with reversed order or shut off all the power supplies simultaneously.

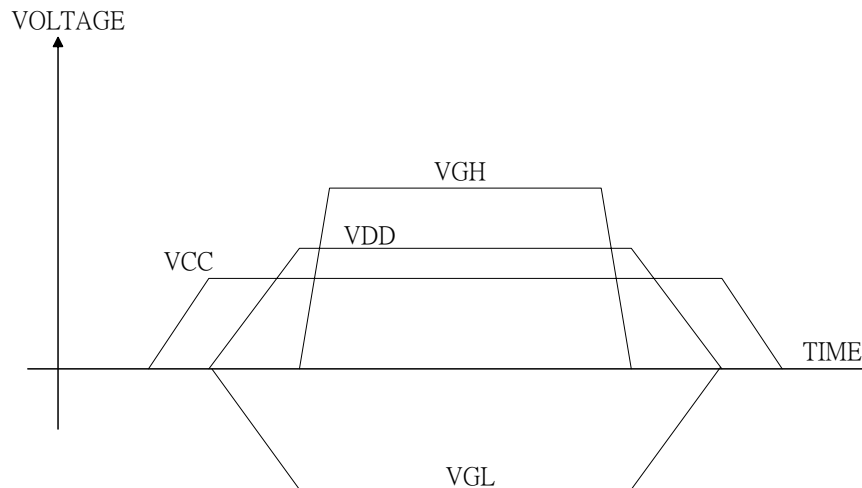

3. QUALITY ASSURANCE SYSTEM

3.1 Quality Assurance Flow Chart

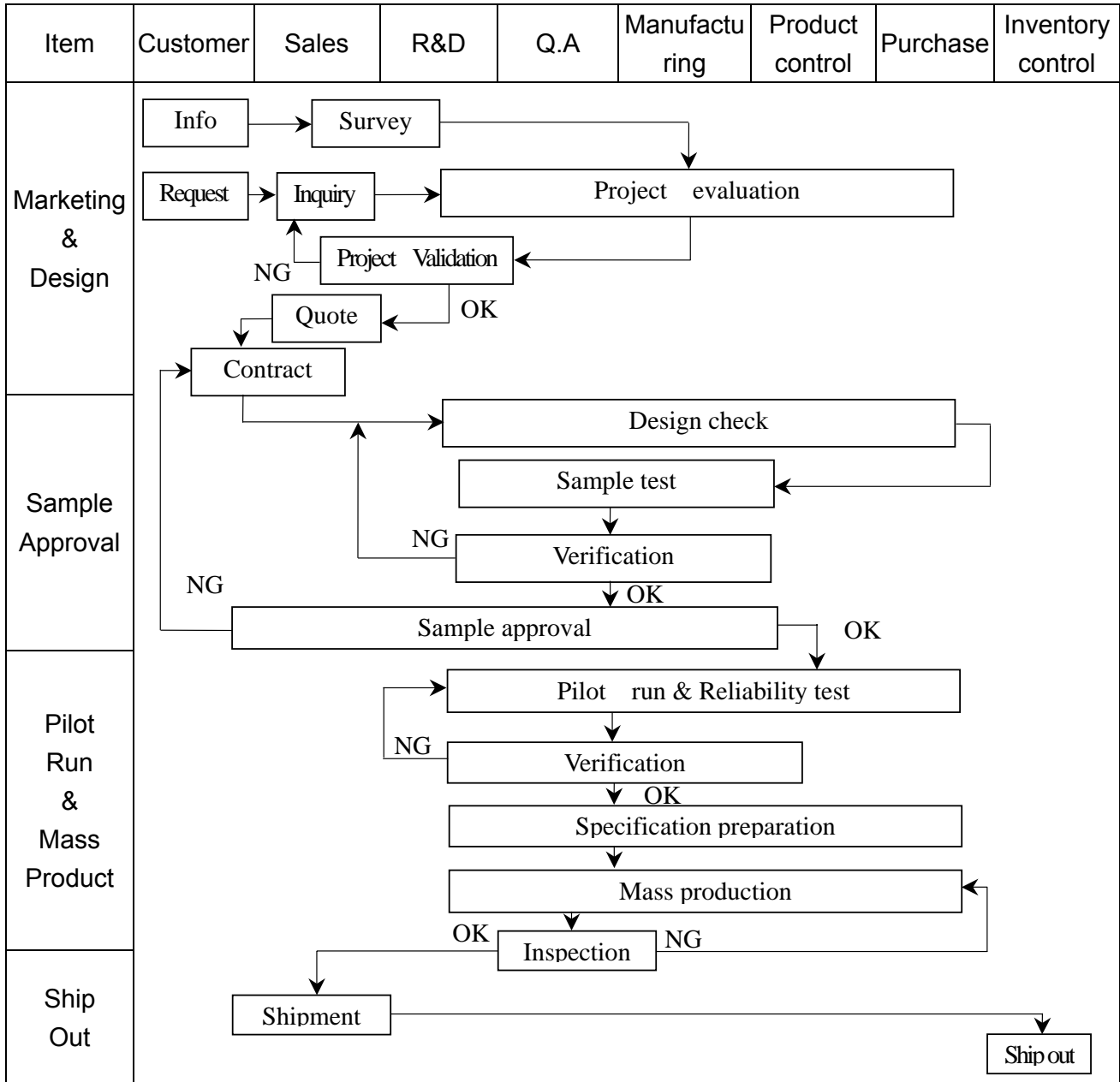

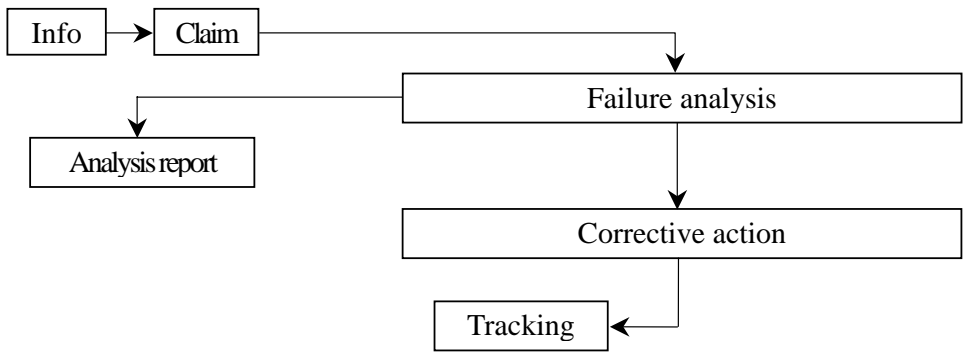
Item	Customer	Sales	R&D	Q.A	Manufacturing	Product control	Purchase	Inventory control
Sales Service	 <pre> graph TD Info[Info] --> Claim[Claim] Claim --> FA[Failure analysis] Claim --> AR[Analysis report] FA --> CA[Corrective action] CA --> Tracking[Tracking] </pre>							
Q.A Activity	1. ISO 9001 Maintenance Activities 3. Equipment calibration 5. Standardization Management				2. Process improvement proposal 4. Education And Training Activities			

3.2 Inspection Specification

Inspection Standard : MIL-STD-105E Table Normal Inspection Single Sampling Level II

Equipment : Gauge , MIL-STD , Powertip Tester , Sample

IQC Defect Level : Major Defect AQL 0.4; Minor Defect AQL 1.5

FQC Defect Level : 100% Inspection

OUT Going Defect Level : Sampling

Specification :

NO	Item	Specification	Judge	Level
1	Part Number	The part number is inconsistent with work order of production	N.G.	Major
2	Quantity	The quantity is inconsistent with work order of production	N.G.	Major
3	Electronic characteristics of LCM $A = (L + W) \div 2$	The display lacks of some patterns.	N.G.	Major
		Missing line.	N.G.	Major
		The size of missing dot, A is $> 1/2$ Dot size	N.G.	Major
		There is no function.	N.G.	Major
		Output data is error	N.G.	Major
4	Appearance of LCD $A = (L + W) \div 2$ Dirty particle (Including scratch 、bubble)	Material is different with work order of production	N.G.	Major
		LCD is assembled in inverse direction	N.G.	Major
		Bezel is assembled in inverse direction	N.G.	Major
		Shadow is within LCD viewing area + 0.5 mm	N.G.	Major
		The diameter of dirty particle, A is > 0.4 mm	N.G.	Minor
		Dirty particle length is > 3.0 mm, and 0.01 mm $<$ width ≤ 0.05 mm	N.G.	Minor
		Display is without protective film	N.G.	Minor
		Conductive rubber is over bezel 1mm	N.G.	Minor
		Polarizer exceeds over viewing area of LCD	N.G.	Minor
		Area of bubble in polarizer, A > 1.0 mm, the number of bubble is > 1 piece.	N.G.	Minor
		0.4 mm $<$ Area of bubble in polarizer, A < 1.0 mm, the number of bubble is > 4 pieces.	N.G.	Minor
5	Appearance of PCB $A = (L + W) \div 2$	Burned area or wrong part number is on PCB	N.G.	Major
		The symbol, character, and mark of PCB are unidentifiable.	N.G.	Minor
		The stripped solder mask , A is > 1.0 mm	N.G.	Minor
		0.3 mm $<$ stripped solder mask or visible circuit, A < 1.0 mm, and the number is ≥ 4 pieces	N.G.	Minor
		There is particle between the circuits in solder mask	N.G.	Minor
		The circuit is peeled off or cracked	N.G.	Minor
		There is any circuits risen or exposed.	N.G.	Minor
		0.2 mm $<$ Area of solder ball, A is ≤ 0.4 mm	N.G.	Minor
		The number of solder ball is ≥ 3 pieces	N.G.	Minor
		The magnitude of solder ball, A is > 0.4 mm.	N.G.	Minor

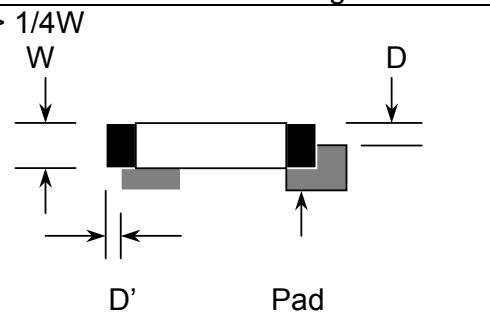
NO	Item	Specification	Judge	Level
6	Appearance of molding $A = (L + W) \div 2$	The shape of modeling is deformed by touching.	N.G.	Major
		Insufficient epoxy: Circuit or pad of IC is visible	N.G.	Minor
		Excessive epoxy: Diameter of modeling is > 20mm or height is > 2.5mm	N.G.	Minor
		The diameter of pinhole in modeling, A is > 0.2mm.	N.G.	Minor
7	Appearance of frame $A = (L + W) \div 2$	The folding angle of frame must be > 45° + 10°	N.G.	Minor
		The area of stripped electroplate in top-view of frame, A is > 1.0mm.	N.G.	Minor
		Rust or crack is (Top view only)	N.G.	Minor
		The scratched width of frame is > 0.06mm. (Top view only)	N.G.	Minor
8	Electrical characteristic of backlight $A = (L + W) \div 2$	The color of backlight is nonconforming	N.G.	Major
		Backlight can't work normally.	N.G.	Major
		The LED lamp can't work normally	N.G.	Major
		The unsoldering area of pin for backlight, A is > 1/2 solder joint area.	N.G.	Minor
		The height of solder pin for backlight is > 2.0mm	N.G.	Minor
10	Assembly parts $A = (L + W) \div 2$	The mark or polarity of component is unidentifiable.	N.G.	Minor
		The height between bottom of component and surface of the PCB is floating > 0.7mm	N.G.	Minor
		$D > 1/4W$  <p>The diagram illustrates a component on a PCB. It shows the component width (W), height (D), and the solder joint width (D') and pad width. The condition $D > 1/4W$ is noted above the diagram.</p>	N.G.	Minor
		End solder joint width, D' is > 50% width of component termination or width of pad	N.G.	Minor
		Side overhang, D is > 25% width of component termination.	N.G.	Minor
		Component is cracked, deformed, and burned, etc.	N.G.	Minor
		The polarity of component is placed in inverse direction.	N.G.	Minor
		Maximum fillet height of solder extends onto the component body or minimum fillet height is < 0.5mm.	N.G.	Minor

4. RELIABILITY TEST

4.1 Reliability Test Condition

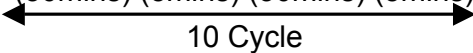
NO	Item	Test Condition	
1	High Temperature Storage	Storage at $80 \pm 2^{\circ}\text{C}$ 96~100 hrs Surrounding temperature, then storage at normal condition 4hrs	
2	Low Temperature Storage	Storage at $-30 \pm 2^{\circ}\text{C}$ 96~100 hrs Surrounding temperature, then storage at normal condition 4hrs	
3	High Temperature /Humidity Storage	1.Storage 96~100 hrs $60 \pm 2^{\circ}\text{C}$, 90~95%RH surrounding temperature, then storage at normal condition 4hrs. (Excluding the polarizer). or 2.Storage 96~100 hrs $40 \pm 2^{\circ}\text{C}$, 90~95%RH surrounding temperature, then storage at normal condition 4 hrs.	
4	Temperature Cycling	$-20^{\circ}\text{C} \rightarrow 25^{\circ}\text{C} \rightarrow 70^{\circ}\text{C} \rightarrow 25^{\circ}\text{C}$ (30mins) (5mins) (30mins) (5mins) 	
5	Vibration	10~55Hz (1 minute) 1.5mm X,Y and Z direction * (each 2hrs)	
6	ESD Test	Air Discharge: Apply 6 KV with 5 times discharge for each polarity +/-	Contact Discharge: Apply 250V with 5 times discharge for each polarity +/-
		Testing location: Around the face of LCD	Testing location: 1.Apply to bezel. 2.Apply to Vcc, Gnd.
7	Drop Test	Packing Weight (Kg)	Drop Height (cm)
		0 ~ 45.4	122
		45.4 ~ 90.8	76
		90.8 ~ 454	61
		Over 454	46

5. PRECAUTION RELATING PRODUCT HANDLING

5.1 SAFETY

- 5.1.1 If the LCD panel breaks , be careful not to get the liquid crystal to touch your skin.
- 5.1.2 If the liquid crystal touches your skin or clothes , please wash it off immediately by using soap and water.

5.2 HANDLING

- 5.2.1 Avoid any strong mechanical shock which can break the glass.
- 5.2.2 Avoid static electricity which can damage the CMOS LSI—When working with the module , be sure to ground your body and any electrical equipment you may be using.
- 5.2.3 Do not remove the panel or frame from the module.
- 5.2.4 The polarizing plate of the display is very fragile. So , please handle it very carefully, do not touch , push or rub the exposed polarizing with anything harder than an HB pencil lead (glass , tweezers , etc.)
- 5.2.5 Do not wipe the polarizing plate with a dry cloth , as it may easily scratch the surface of plate.
- 5.2.6 Do not touch the display area with bare hands , this will stain the display area.
- 5.2.7 Do not use ketonics solvent & aromatic solvent. Use with a soft cloth soaked with a cleaning naphtha solvent.
- 5.2.8 To control temperature and time of soldering is $280 \pm 10^{\circ}\text{C}$ and 3-5 sec.
- 5.2.9 To avoid liquid (include organic solvent) stained on LCM

5.3 STORAGE

- 5.3.1 Store the panel or module in a dark place where the temperature is $25^{\circ}\text{C} \pm 5^{\circ}\text{C}$ and the humidity is below 65% RH.
- 5.3.2 Do not place the module near organics solvents or corrosive gases.
- 5.3.3 Do not crush , shake , or jolt the module.

5.4 TERMS OF WARRANTY

- 5.4.1 Applicable warrant period
The period is within thirteen months since the date of shipping out under normal using and storage conditions.
- 5.4.2 Unaccepted responsibility
This product has been manufactured to your company's specification as a part for use in your company's general electronic products. It is guaranteed to perform according to delivery specifications. For any other use apart from general electronic equipment, we cannot take responsibility if the product is used in nuclear power control equipment, aerospace equipment , fire and security systems or any other applications in which there is a direct risk to human life and where extremely high levels of reliability are required.

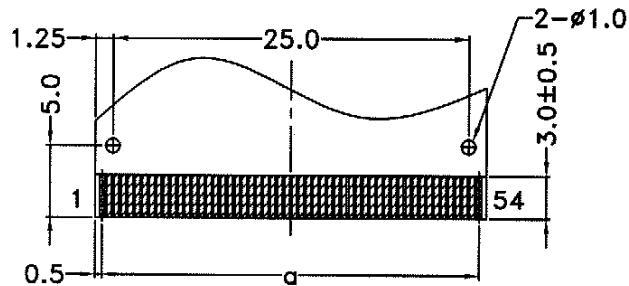
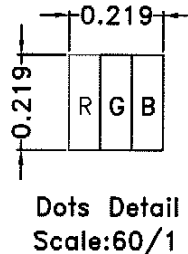
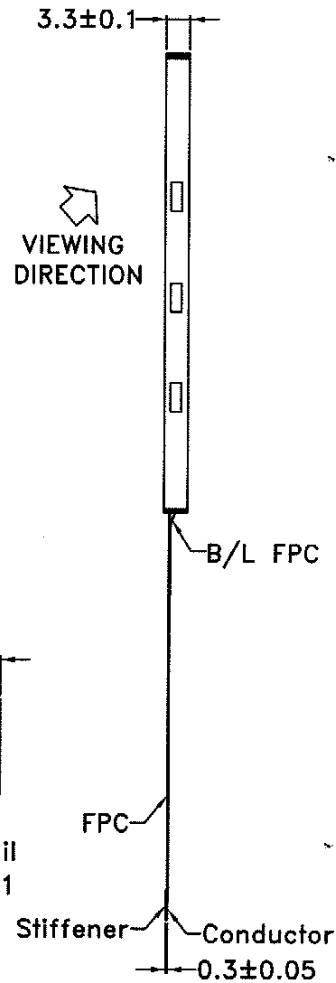
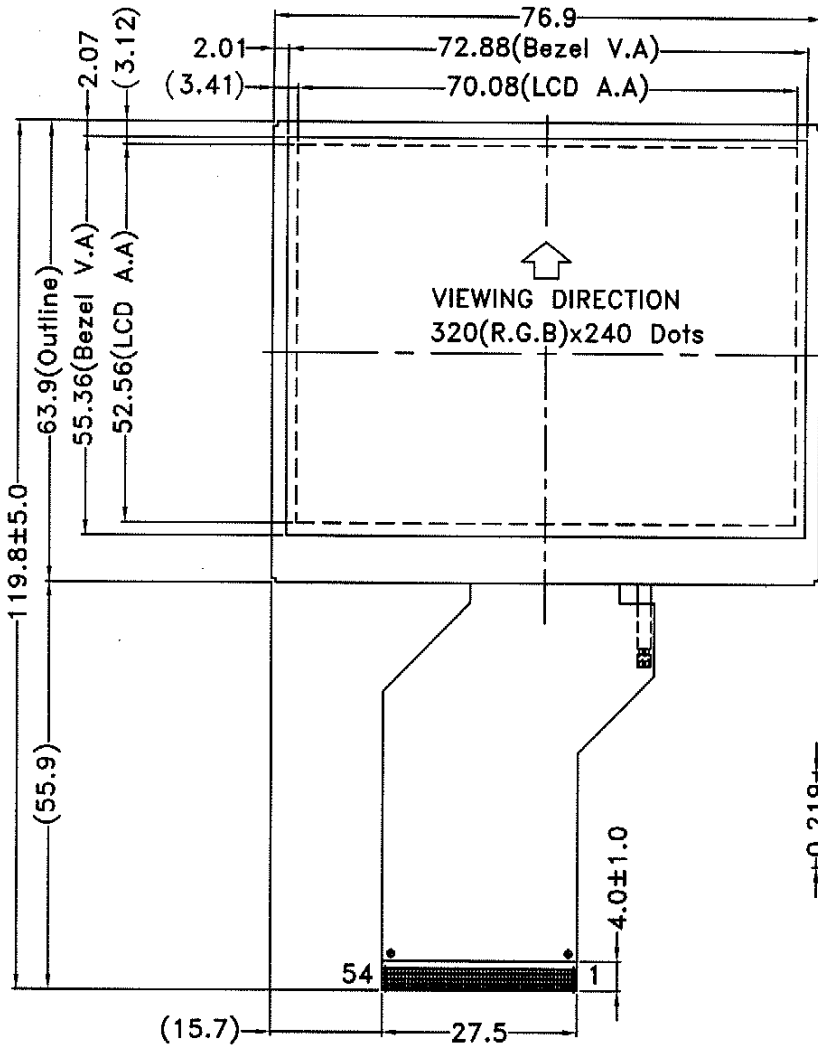

FPC Detail Scale:2/1

- NOTES:
- 1.LCD TYPE: a-Si TFT
 - 2.LCD DISPLAY:POSITIVE/ TRANSMISSIVE
 - 3.VIEW DIRECTION: 6 O'CLOCK
 - 4.Top: -20~70°C Tst:-30~80°C
 - 5.The tolerance unless classified ±0.3mm
 - 6.a=P0.5x53=26.5±0.1,W=0.35±0.05

REV	DESCRIPTION	DATE
■■■久正光電股份有限公司 ■■■POWERTIP TECHNOLOGY CORPORATION		
⊕	SCALE:1/1 UNIT:mm PAGE:1/1	APPROVED
圖面名稱	PH320240T-004-IC1Q	CHECKER
圖面編號	PH-06005-004 EDI 0	DRAWN

Approval and drawing information:



- APPROVED: 95.7.7 張慶源
- CHECKER: 95.7.5 黃如珊
- DRAWN: 95.7.5 李美倫

LCM Model	PH320240T-004-IC1Q
版次Ver.0	

LCM包裝規格書

LCM Packaging Specifications

(For Tray)

Approve	Check	Contact
		

1. 包裝材料規格表 (Packaging Material) : (per carton)

No.	Item	Model	Dimensions (mm)	Quantity
1	成品 (LCM)	PH320240T-004-IC1Q	76.9 X 63.9	288
2	多層薄膜(1)POF	OTFILM0BA03ABA	19"X350X0.015	6
3	TRAY 盤 (2)	TY32024001TZBA	352 X 260 X 10.8	54
4	內盒(3)Product Box	BX36627063ABBA	393 X 274 X 68	6
5	保力龍板(4)Polylon board	OTPLB00PL08ABA	550 X 393 X 20	2
6	外紙箱(5)Carton	BX57041027CCBA	570 X 410 X 265	1
7				
8				
9				

2. 單箱數量規格表 (Packaging Specifications and Quantity) :

(1) LCM quantity per box : no per tray	6	x no per tray	8	=	48
(2) Total LCM quantity in carton : quantity per box	48	x no of boxes	6	=	288

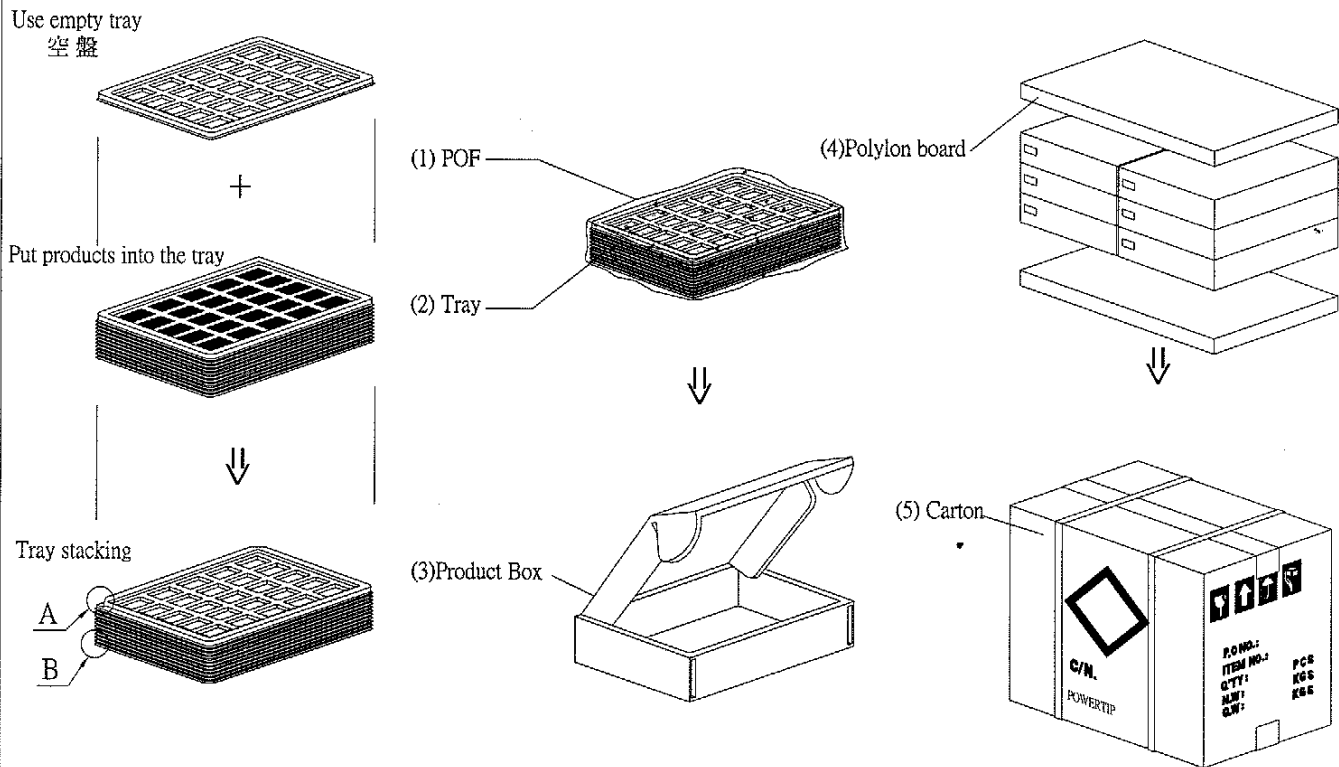

特 記 事 項 (REMARK)

MODEL:
 LOT NO:
 QUANTITY:
 CHECK:

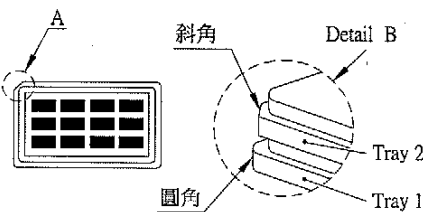

Rotate tray 180 degrees and place on top of stack.
 Check the tray stack using Fig. B.
 TRAY盤相疊時,需旋轉180度,請詳見B視圖

3.It's also suitable to Panel
 (可適用於單品包裝)
 TRAY Number:PH320240T-001