

Marvell Alaska 88X201x

Integrated 10 Gbps 802.3ae Compliant Ethernet Transceivers



PRODUCT OVERVIEW

The Marvell® Alaska® X 88X201x series of physical layer (PHY) transceivers is a complete solution for 10GBASE-SR/LR/ER/SW/LW/EW 802.3ae compliant applications.

The 88X2010, 88X2011, 88X2012, and 88X2013 transceivers are fully integrated single-chip devices that perform all the physical functions for 10 Gigabit Ethernet (GbE), 10 Gigabit Fibre Channel LAN (88X2010, 88X2012), and LAN/WAN (88X2011, 88X2013) applications, delivering high-speed bi-directional point-to-point data transmissions. The devices provide flexibility with the 88X2010 and 88X2011 supporting the 10 GbE Attachment Unit Interface (XAUI), and the 88X2012 and 88X2013 supporting the 10 Gigabit Media Independent Interface (XGMII); each adhering to IEEE 802.3ae specifications.

The 88X2012 and 88X2013 include the PMD, PMA, WIS (88X2013 only), and PCS sub-layer standards. The 88X2010 and 88X2011 additionally have an integrated XGXS function for XAUI support (with 88X2011 supporting additional WIS). Each of these Alaska X 10 GbE PHYs is housed in design-efficient 256-pin 17x17 TFBGA packages.

The Alaska X 88X201x PHYs enable short reach (SR/SW), long reach (LR/LW), or extended reach (ER/EW) applications for module implementation or system board implementation in LAN or LAN/WAN form. On the system side, the PHYs can support XAUI or XGMII modes; while on the line-side they support the serial 10 Gbps XFI interface. The XFI interface is ideal for connecting to the smaller XFP module. In cases of XENPAK, XPAK, or X2 module designs the 88X2011 or 88X2010 can be integrated onto the module itself.

BLOCK DIAGRAM

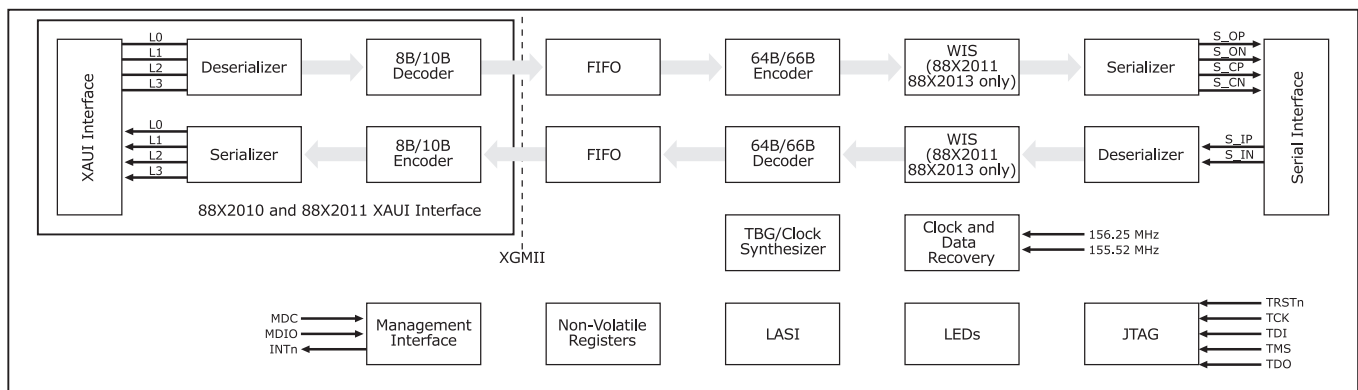

Fig 1. Marvell 10 Gbps Ethernet PHYs—88X2010 LAN XAUI/XFI PHY, 88X2011 LAN/WAN XAUI/XFI PHY, 88X2012 LAN XGMII/XFI PHY, and 88X2013 LAN/WAN XGMII/XFI PHY

KEY FEATURES AND BENEFITS

FEATURES	BENEFITS
<ul style="list-style-type: none"> XAUI system-side interface (88X2011/10) 	<ul style="list-style-type: none"> Compatible mode with industry standard interface
<ul style="list-style-type: none"> XGMII system-side interface (88X2012/13) 	<ul style="list-style-type: none"> Low pin count, increased PCB trace-ability and lower power
<ul style="list-style-type: none"> Fully integrated limiting amplifier, CMU/CDR, SERDES, PCS/PMA 	<ul style="list-style-type: none"> Enables support for legacy switch and MAC interfaces
<ul style="list-style-type: none"> Optional WIS for EOS (Ethernet Over SONET) and WAN applications (88X2011/13) 	<ul style="list-style-type: none"> Single-chip solution for 10 GbE applications
<ul style="list-style-type: none"> Integrated XFP reference clock output (divide by 64) 	<ul style="list-style-type: none"> Ability to support LAN only or both LAN/WAN applications with a single transceiver
<ul style="list-style-type: none"> Exceed SONET jitter requirements 	<ul style="list-style-type: none"> Eliminates requirement for separate XFP reference clock Reduce BOM (bill of materials)
<ul style="list-style-type: none"> XG-MDC/MDIO management interface 	<ul style="list-style-type: none"> Surpasses stringent SONET jitter requirements
<ul style="list-style-type: none"> Industrial temperature support (88X2011) 	<ul style="list-style-type: none"> Flexible management options Support for extreme temperature requirements

APPLICATIONS

The Alaska X 88X201x series of 10 GbE PHYs are integrated, flexible solutions for system-level or module applications. The devices support both XGMII and XAUI MAC interfaces, while additionally offering LAN and WAN line-side support, thus presenting a full portfolio of products for any application. Their small footprint facilitates XENPAK, XPAK, and X2 module applications.

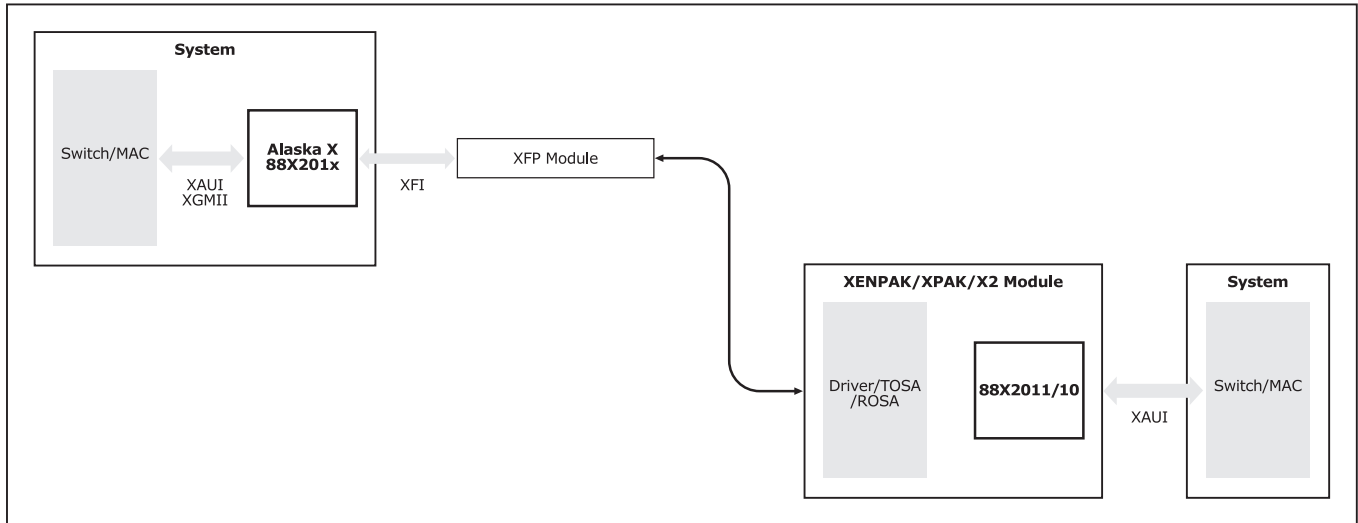

Fig 2. Marvell 10 GbE PHY System and Module Implementation

Part Number	XAUI	XGMII	XFI	ER/LR/SR	EW/LW/SW	RoHS
88X2010	x		x	x		x
88X2011	x		x	x	x	x
88X2012		x	x	x		x
88X2013		x	x	x	x	x

THE MARVELL ADVANTAGE: Marvell chipsets come with complete reference designs which include board layout designs, software, manufacturing diagnostic tools, documentation, and other items to assist customers with product evaluation and production. Marvell’s worldwide field application engineers collaborate closely with end customers to develop and deliver new leading-edge products for quick time-to-market. Marvell utilizes world-leading semiconductor foundry and packaging services to reliably deliver high-volume and low-cost total solutions.

ABOUT MARVELL: Marvell is a leader in storage, communications, and consumer silicon solutions. Marvell’s diverse product portfolio includes switching, transceiver, communications controller, processor, wireless, power management, and storage solutions that power the entire communications infrastructure, including enterprise, metro, home, storage, and digital entertainment solutions. For more information, visit our Web site at www.marvell.com.



Marvell Semiconductor, Inc.
5488 Marvell Lane
Santa Clara, CA 95054
Phone 408.222.2500
www.marvell.com

Copyright © 2007. Marvell International Ltd. All rights reserved. Marvell, the Marvell logo, Moving Forward Faster, Alaska, Datacom Systems on Silicon, Fastwriter, Libertas, Link Street, NetGX, PHYAdvantage, Presteria, Raising The Technology Bar, The Technology Within, Virtual Cable Tester, and Yukon are registered trademarks of Marvell. Marvell Makes It All Possible, Ants, AnyVoltage, Discovery, DSP Switcher, Feroceon, GalNet, GalTis, Horizon, RADLAN, UniMAC, and VCT are trademarks of Marvell. All other trademarks are the property of their respective owners.