

FX-104 Frequency Translator



Features

- Output frequencies to 850 MHz
- Jitter Generation OC-192 Compliant
- Jitter Transfer per GR-253-Core
- Single 5V or 3.3V Supply
- Locked to specific input frequency, e.g. 8 kHz
- 1" x 0.8" x 0.25", Surface Mount (FR4 based)
- RoHS/Lead Free Compliant



Applications

- SONET / SDH / ATM / DSL-PON Interconnects
- 8 kHz/19.44 MHz/155.52 MHz to 622.08 MHz

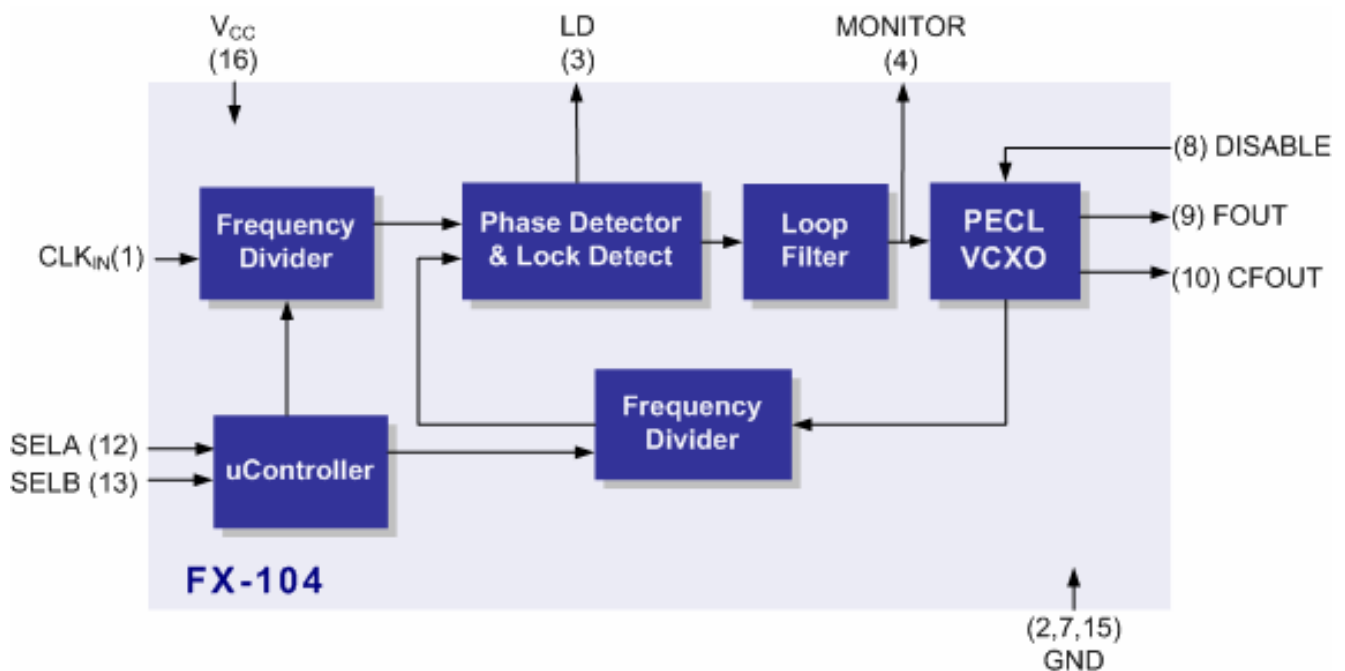

FX-104 Frequency Translator

Description

Vectron's FX-104 is a SAW based frequency translator which is used to translate any input frequency such as 8 kHz, 1.544 MHz, 2.048 MHz, 19.440 MHz etc. to any specific frequency from 170 MHz to 777.6 MHz. The input frequency does not have to be a 50/50% duty cycle and as an example can be an 8 kHz signal with a logic high "on time" of only 1us, such as a BITS clock. The FX-104 also has the ability to translate any of 1 to 4 different input frequencies to one common output frequency, such as input frequencies of 8 kHz and 1.544 MHz and 19.44 MHz and any other frequency between 333 Hz and 170 MHz translating them to any specific output frequency from 170 MHz to 777.600 MHz.

The "Input Frequency tracking capability" is the total amount of input frequency deviation in which the FX-104 is guaranteed to track or translate. As an example, a typical input clock would be 8 kHz \pm 20 ppm. The FX-104 is guaranteed to track at least \pm 40 ppm of error over temperature/aging/ power supply and is more than twice what most applications require. The PLL control voltage is brought out through a 470K ohm resistor. This would allow for the use of external circuitry (analog comparators or an A/D converter plus a processor) to detect when the control voltage is getting close to the limits of the pull range.

Performance Characteristics

Parameter	Symbol	Minimum	Typical	Maximum	Units
Supply Voltage, C = 5 Vdc D = 3.3 Vdc	V _{CC} V _{CC}	4.75 3.135	5.00 3.30	5.25 3.465	Vdc Vdc
Supply Current (3.3 Vdc or 5 Vdc)	I _{CC}		95	125	mA
Input Signal,	CLKIN		HCMOS or PECL		---
OUTPUT, F = Comp PECL	---	---	PECL	---	---
V _{OL} (@+25°C)	V _{OL}	V _{CC} -1.95		V _{CC} -1.63	V
V _{OH} (@+25°C)	V _{OH}	V _{CC} -0.98		V _{CC} -0.75	V
Rise / Fall Time (20% to 80% @ 622.08 MHz)	t _R /t _F		250	400	ps
Output Symmetry	Sym	45	49/51	55	%
Jitter Generation, rms (12kHz to 20MHz)			0.23	1.0	ps
Jitter Generation, rms(cycle to cycle method)			3		ps
Jitter Transfer, GR-253 section 5.6.2.1.2				0.1	dB
Min Pulse Width @ 8 kHz		1			us
Input Frequency Tracking Capability (Can translate a Stratum 1,2,3,3E,4 or SONET Min source)	APR	+/-40			ppm
Operating Temperature		Temp Range C = 0°C to +70°C Temp Range F = -40°C to +85°C			
Size		See page 3 for outline Drawings and Dimensions			

FX-104 Frequency Translator

Outline Drawing

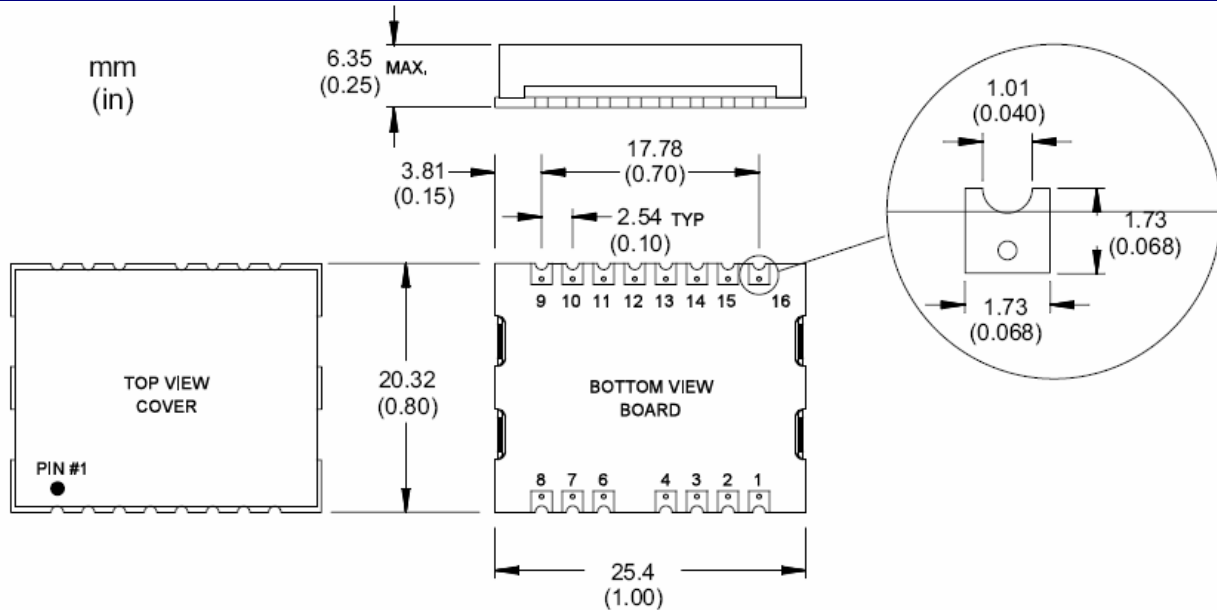

Pin	Symbol	Function
1	CLKIN	Input Frequency - The FX-104 series AC couples the input, this means the unit is capable of handling HCMOS, LvHCMOS, PECL and LvPECL input signals. (For Input Frequencies below 1.0 MHz only HCMOS and LvHCMOS are supported)
2	GND	Ground
3	LD (Output)	Lock Detect Logic "1" indicates a locked condition Logic "0" indicates that no input signal is presented
4	Monitor (Output)	PLL/ VCXO control voltage Under locked conditions, should be >0.3V and <3.0V for the 3.3 volt option or >0.5V and <4.5V for the 5 volt option. Input frequency may be out of range if voltage exceeds these limits.
5	--	Missing
6	NC	No Connection
7	GND	Ground
8	Disable (Input)	Disables Output Floating = Output enabled Logic "0" = Output disabled
9	OUT	VCXO Output (PECL)
10	COUT	Complementary VCXO Output (PECL)
11	NC	No Connection
12	Select A	Do not Exceed V_{CC}
13	Select B	Do not Exceed V_{CC}
14	NC	No Connection
15	GND	Ground
16	V_{CC}	5 Vdc or 3.3 Vdc

FX-104 Frequency Translator

Recommended Pad Layout

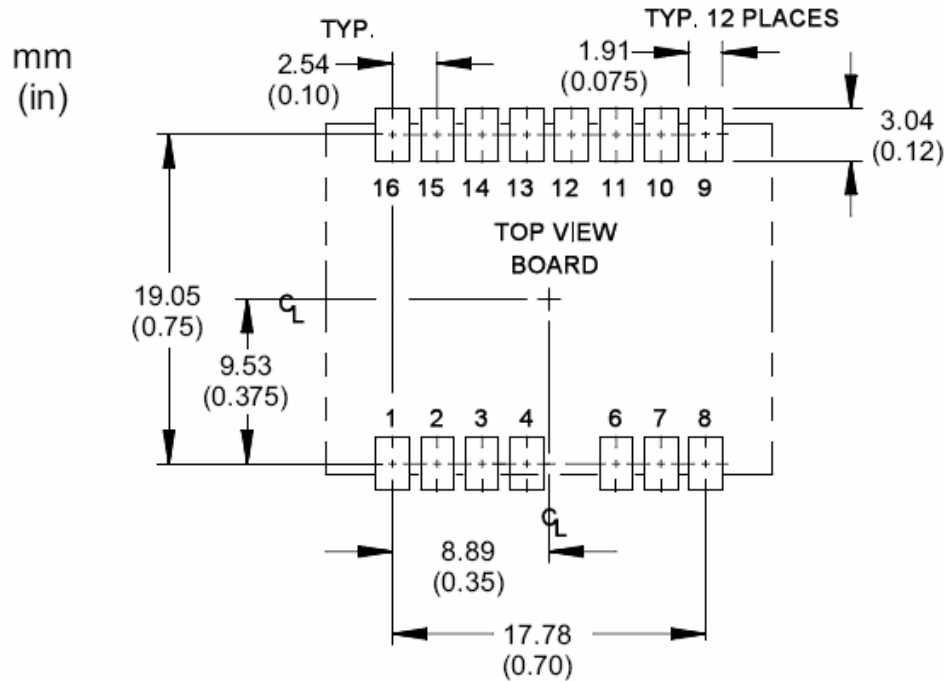

Reflow Profile (IPC/JEDEC J-STD-020C)

Parameter	Symbol	Value
PreHeat Time	t_s	60 sec Min, 180 sec Max
Ramp Up	R_{UP}	3 °C/sec Max
Time Above 217 °C	t_L	60 sec Min, 150 sec Max
Time To Peak Temperature	t_{AMB-P}	480 sec Max
Time At 260 °C	t_P	20 sec Min, 40 sec Max
Ramp Down	R_{DN}	6 °C/sec Max

The FX-104 is being qualified to meet the JEDEC standard for Pb-Free assembly. The temperatures and time intervals listed are based on the Pb-Free small body requirements. The temperatures refer to the topside of the package, measured on the package body surface. The FX-104 should not be subjected to a wash process that will immerse it in solvents. NO CLEAN is the recommended procedure. The FX-104 has been designed for pick and place reflow soldering. The FX-104 may be reflowed once and should not be reflowed in the inverted position.

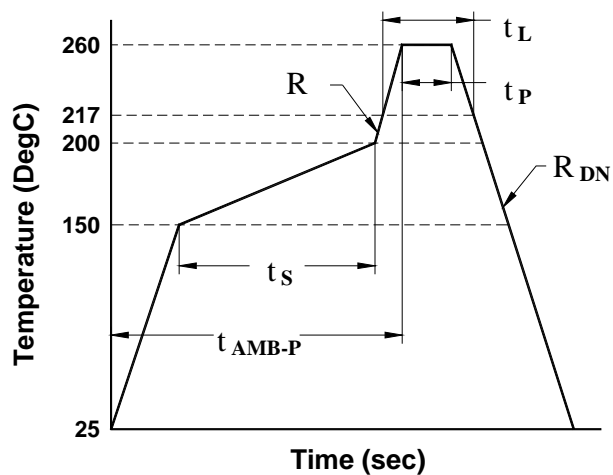

FX-104 Frequency Translator

Standard Shipping Method

The Standard ship method for volume production of the FX-100 series is in a matrix tray. These trays are 100% recyclable. The trays also offer the added feature that they can be continuously feed into a pick-n-place machine eliminating the down time required with tape-n-reel.

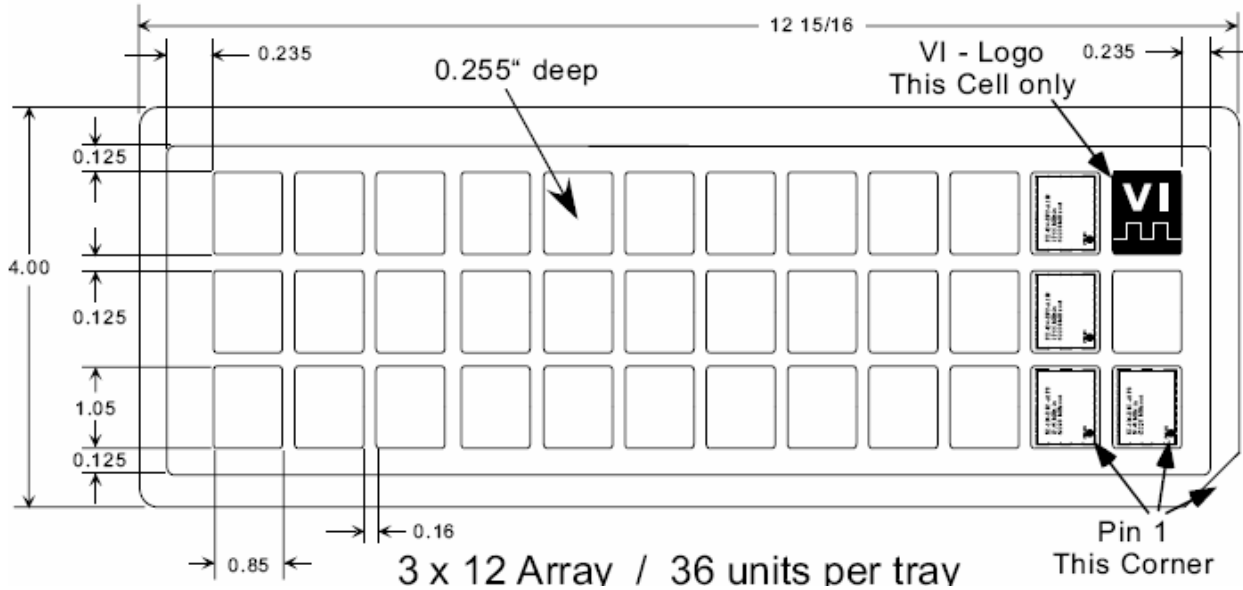

Handling Precautions

Although protection circuitry has been designed into this device, proper precautions should be taken to avoid exposure to electrostatic discharge (ESD) during handling and mounting. VI employs a human-body model (HBM) and a charged-device model (CDM) for ESD-susceptibility testing and protection design evaluation. ESD voltage thresholds are dependent on the circuit parameters used to define the mode.

Although no industry-wide standard has been adopted for the CDM, a standard HBM (resistance = 1500 ohms, capacitance = 100pf) is widely used and therefore can be used for comparison purposes. The HBM ESD threshold presented here was obtained by using these circuit parameters.

ESD Threshold Voltage		
Model	Threshold	Unit
Human-Body (HBM)	500	V min
Charged-Device	500	V min

FX-104 Frequency Translator

Typical Application

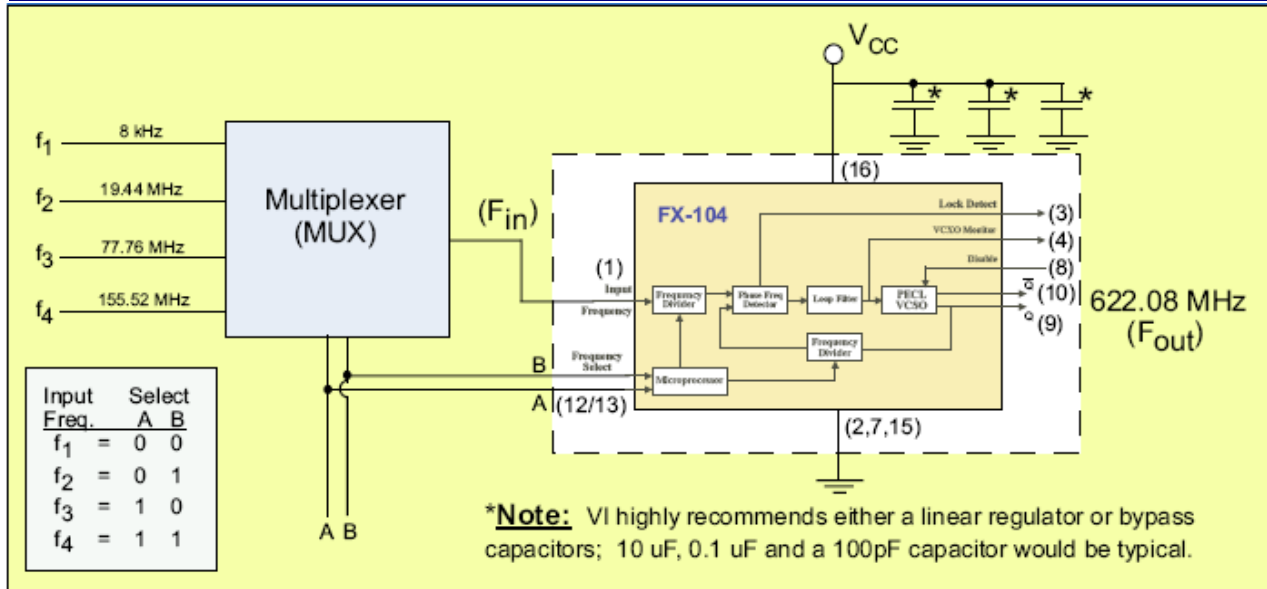

Output Load Configuration

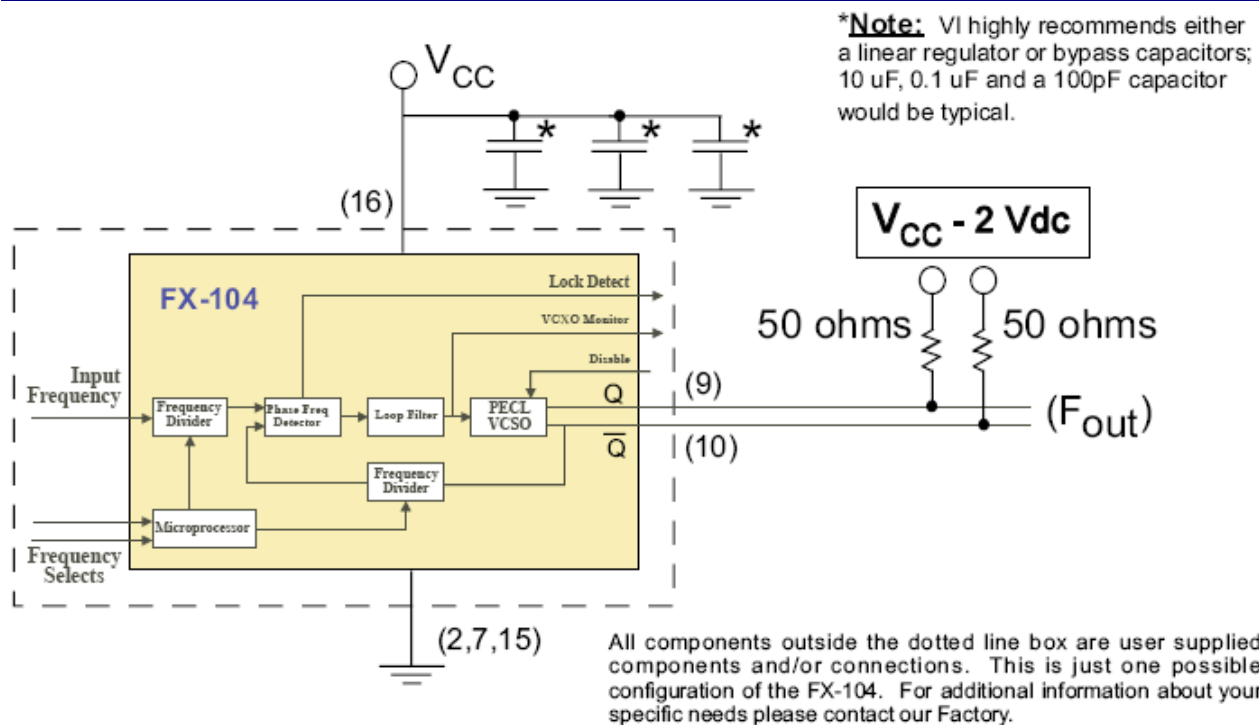

FX-104 Frequency Translator

FX-100 Series Selection Guide

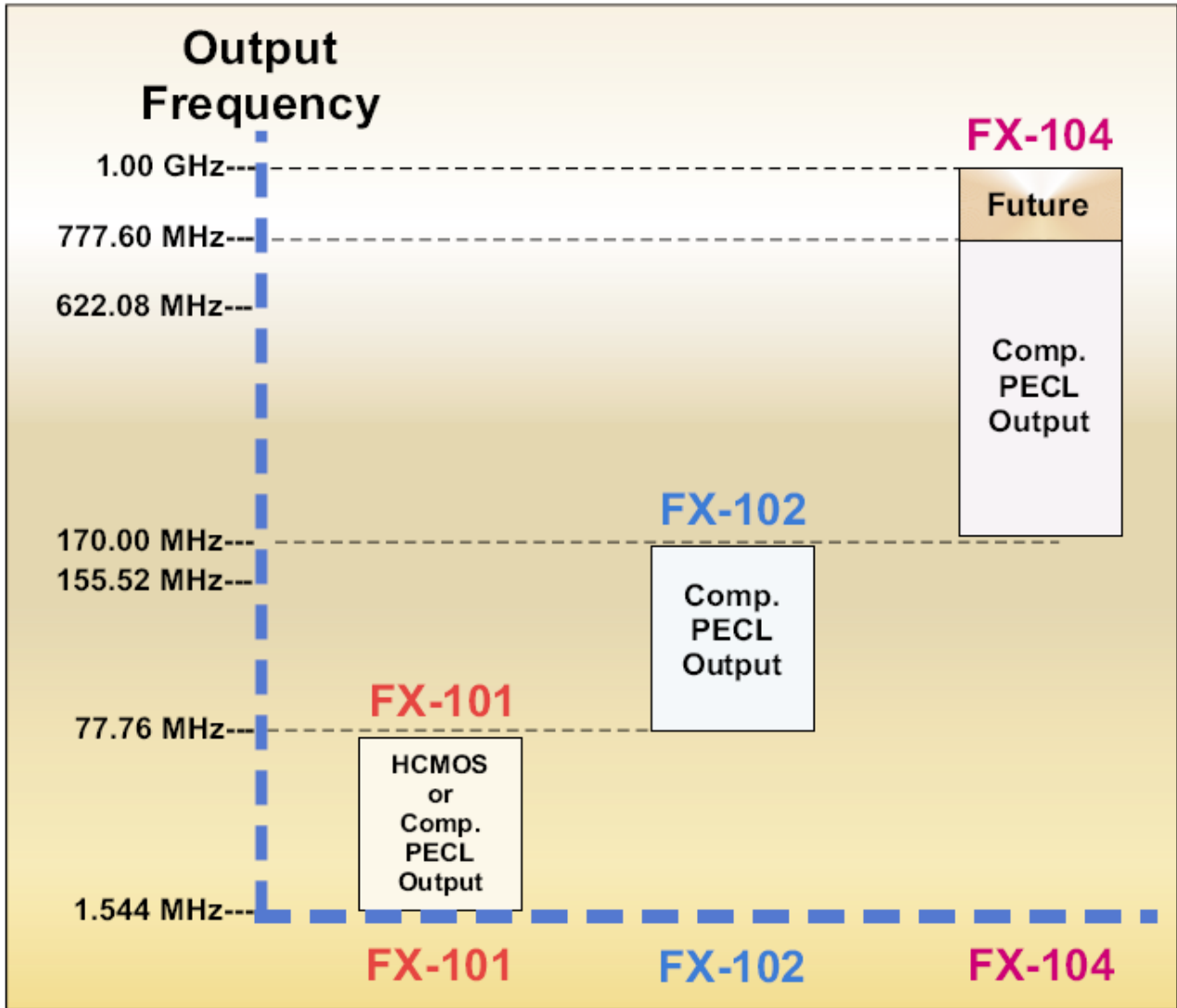

FITS / MTBF Calculations

Per Bellcore TR-NWT-000332, GF @ +50°C.

Typical - FX-104-DFC-A1P8

Fits = 316.88

MTBF (Hours) = 3,155,819

FX-104 Frequency Translator

FAQ's

Q1: What are the different input frequencies that are available?

A: The FX-100 series is able to handle any input frequency between 8 kHz and 170 MHz. (A list of standard frequencies is available on pages 9 & 10)

Q2: How many different input frequencies can a specific FX-104 accept?

A: Each FX-104 can be programmed to accept up to 4 different frequencies.

Q3: If there is only one input pin, how can your unit accept 4 different frequencies?

A: The user is required to supply a multiplexer which would switch between the different input frequencies. The multiplexers' select pins would need to be sync'd to the select pins of the FX-104. (See The Typical Application illustrated on page 6)

Q4: Can a single FX-104 handle an application for 4 input frequencies of 8 kHz, 19.44, 77.76 and 155.52 MHz all being translated to 622.08 MHz, with the 155.52 MHz input being LvPECL and the others HCMOS?

A: Yes; since the FX-104 AC couples the input signal, this combination can be supported.

Q5: What is the lock time for the FX-104?

A: The exact lock time will depend on the specific input frequency. It should be noted that in all cases the lock time will be significantly less than 1 second.

Q6: I asked for a FX-104-DFC-A2S8 with 19.44 and 155.52 MHz for the input frequencies and was given a Source Control Drawing (SCD) number of FX-104-DFC-S5999 Why was a new number assigned?

A: Whenever there are multiple input frequencies, we need to assign a SCD for the unit so that we can include a table indicating what the logic levels need to be on pins 12 and 13 to control the unit per the correct input frequency.

Q7: What are the exact jitter transfer specs that the FX-104 series meets?

A: The FX-104 meets the stringent jitter transfer specs in GR-253 for Category II jitter (Section 5.6.2.1.2) for all OC-n levels.

Q8: My circuit card is already laid out for the FX-102, Is the FX-104 footprint compatible?

A: Yes; The FX-104 package is a drop in replacement for the FX-102 package. The only difference is in the logic level for the Output Disable/Enable pin. They are opposite between the FX-102 and FX-104. However letting pin 8 float will allow both units to be enabled.

Q9: What type of noise on the supply line can the FX-104 suppress?

A: The FX-104 is designed to clean up noise on the Input Clock Signal, it is not designed to clean up noisy power supplies. If excessive noise is present on the supply line it may degrade the output jitter performance. Additional external filtering may be required. Please consult with your power supply vendor on the best way to filter noise on your supply line.

FX-104 Frequency Translator

Evaluation Board

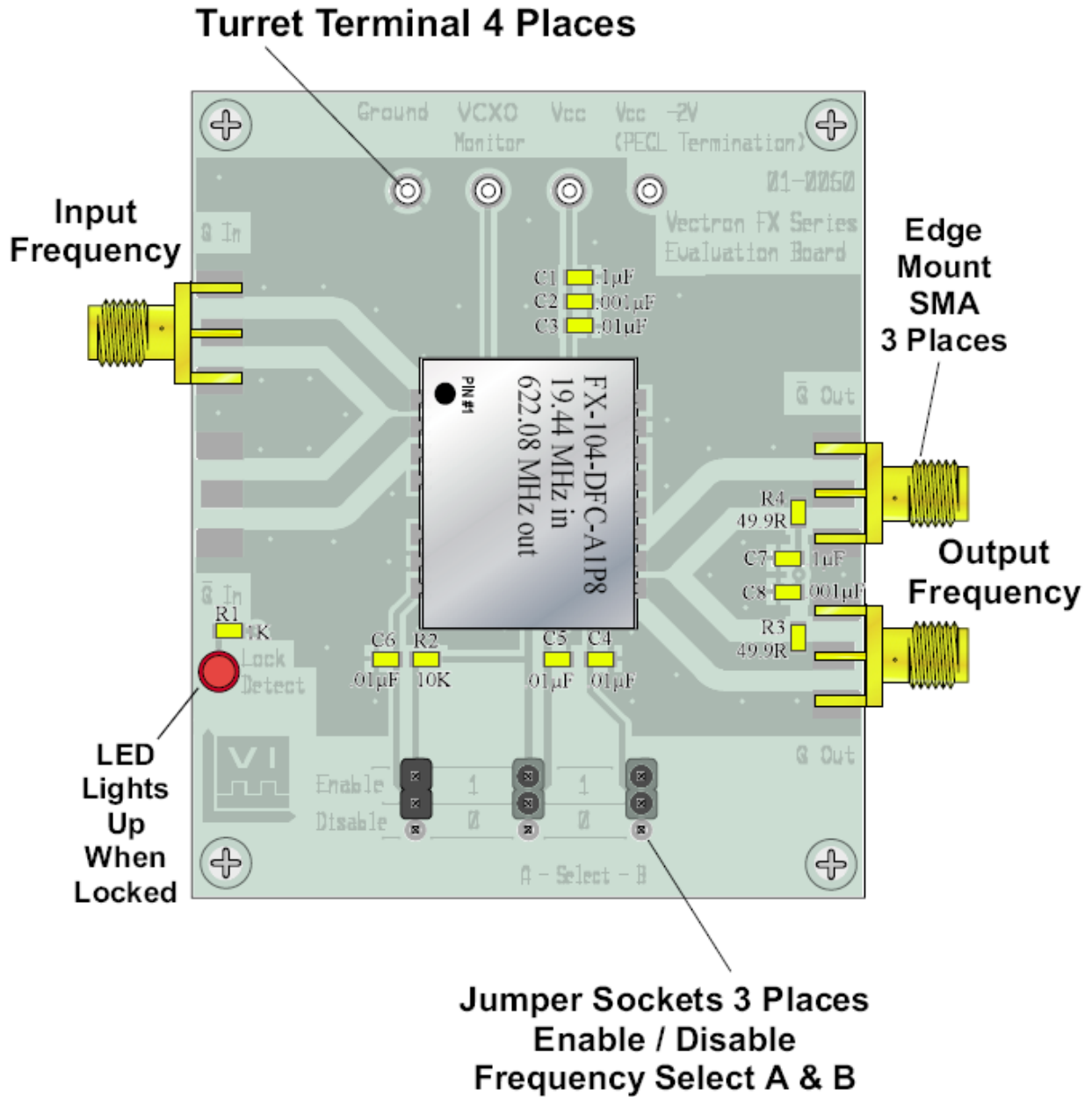

Evaluation boards are available upon request.

FX-104 Frequency Translator

Other Standard Input / Output Combinations

Input 1	Input 2	Input 3	Input 4	Output
12.8 MHz	---	---	----	622.08 MHz
22.2171 MHz	44.4343 MHz	77.76 MHz	----	622.08 MHz
19.44 MHz	51.84 MHz	155.52 MHz	----	622.08 MHz
8.0 kHz	22.2171 MHz	155.52 MHz	----	622.08 MHz
8.0 kHz	19.44 MHz	77.76 MHz	155.52 MHz	622.08 MHz
19.44 MHz	38.88 MHz	77.76 MHz	155.52 MHz	622.08 MHz
156.25 MHz	---	---	----	625.00 MHz
20.1416 MHz	---	---	----	644.5313 MHz
161.1328 MHz	---	---	----	644.5313 MHz
22.2171 MHz	---	---	----	666.5143 MHz
77.76 MHz	---	---	----	666.5143 MHz
20.1416 MHz	---	---	----	690.5692 MHz

The combinations above are just a small sample of what is possible with the FX-104 series.

The FX-104 uses Vectron International's VS-500 VCSO and as such can support any output frequency that is available with the VS-500. The list below shows the available frequencies for the VS-500.

Vectron International will support all FEC rates for SONET, 10 GigE and 10.3125 GigE applications. If you do not see a frequency option listed that you need please contact the factory.

When ordering FEC rates, we ask that you also include the FEC ratio (e.g. 255/237 x OC-3, 237/236 x OC-3,etc....) for both the input and output frequencies.

VS-500 Available Frequencies (MHz)

155.5200	156.2500	161.1328	166.6286
177.7371	311.0400	622.0800	624.7048
625.0000	627.3296	644.5313	666.5143
669.1281	669.3265	690.5692	719.73439
765.5906	767.2500	777.6000	

FX-104 Frequency Translator

Standard Frequencies

8 kHz	C	19.44 MHz	P	112.00 MHz	4
16 kHz	D	20.48 MHz	R	139.264 MHz	5
64 kHz	E	26.00 MHz	T	155.52 MHz	6
1.024 MHz	F	27.00 MHz	W	166.6286 MHz	7
1.544 MHz	H	38.88 MHz	X	622.08 MHz	8
2.048 MHz	J	44.736 MHz	Y	666.5143 MHz	9
4.096 MHz	K	51.84 MHz	0		
8.192 MHz	L	61.44 MHz	1		
13.00 MHz	M	77.76 MHz	2		
16.384 MHz	N	82.944 MHz	3	Special SCD	S

How to Order

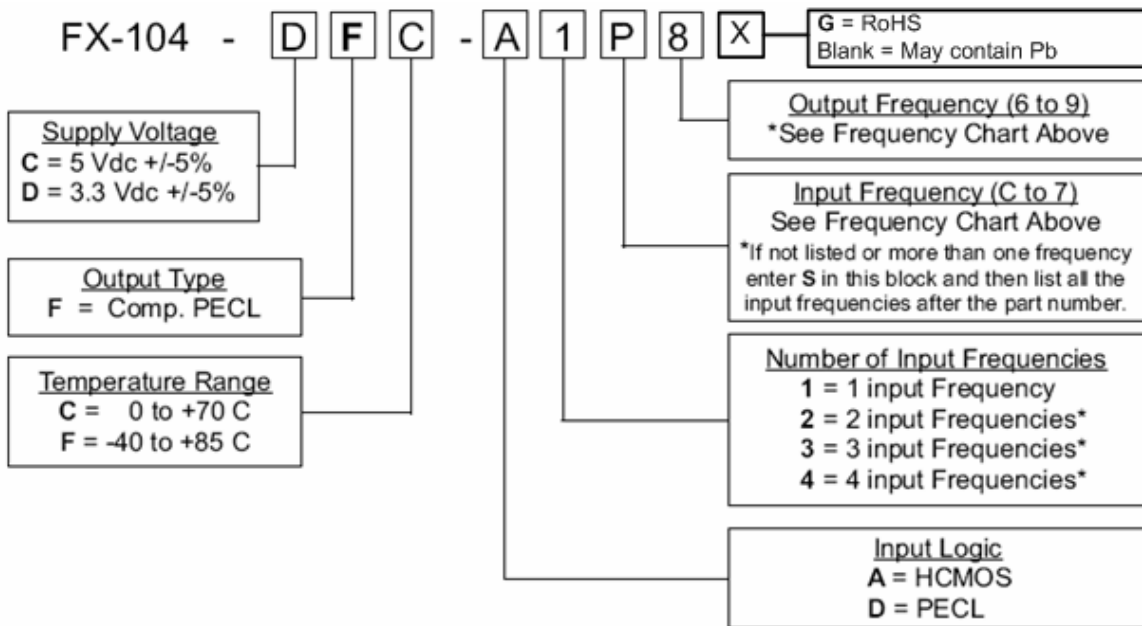

*If not listed or more than one input frequency a special SCD number will be assigned.

Part Numbers Examples:

FX-104-DFC-D128

*FX-104-DFF-A4S8 - 8 kHz, 19.44MHz, 77.76MHz, 155.52MHz

For Additional Information, Please Contact:



USA: Tel: 1-88-VECTRON-1 Fax: 1-888-FAX-VECTRON
 EUROPE: Tel: +49 (0) 7268 8010 Fax: +49 (0) 7268 8012 81
 ASIA: Tel: +86-21-5048-0777 Fax: +86-21-5048-1881

Vectron International reserves the right to make changes to the product(s) and or information contained herein without notice.
 No liability is assumed as a result of their use or application. No rights under any patent accompany the sale of any such product(s) or information.

Vectron International, 267 Lowell Road, Hudson, NH 03051

Tel: 1-88-VECTRON-1 • Web: www.vectron.com