

MFL Single and Dual DC/DC Converters

28 VOLT INPUT – 65 WATT

FEATURES

Parallel operation with current share,
up to 3 units (up to 185 watts)

- -55° to +125°C operation
- 16 to 40 VDC input
- 50 V for 50 ms transient protection
- Fully isolated, magnetic feedback
- Fixed high frequency switching
- Remote sense or output trim on single output models
- Inhibit function
- Sync in and Sync Out
- Indefinite short circuit protection
- High power density with up to 87% efficiency



MODELS VDC OUTPUT

SINGLE	DUAL
3.3	±5
5	±12
12	±15
15	
28	

Other output voltages
available upon request,
including 2 V, 8 V and
54 V single.

DESCRIPTION

The Interpoint™ MFL Series™ 28-volt DC/DC converters are rated up to 65 watts with an overall power density of up to 43 watts per cubic inch. On dual output models up to 70% of the rated output power can be drawn from either the positive or negative output. These hermetically sealed converters are offered with standard screening, “ES” screening, or fully compliant to “883” MIL-PRF-38534 Class H screening. Standard microcircuit drawings (SMD) are available.

DESIGN FEATURES

The MFL Series converters are switching regulators that use a quasi-square wave, single ended forward converter design with a constant switching frequency of 600 kHz.

Isolation between input and output circuits is provided with a transformer in the forward path and a wide bandwidth magnetic coupling in the feedback control loop. The MFL uses a unique dual loop feedback technique that controls output current with an inner feedback loop and an output voltage with a cascaded voltage mode feedback loop.

The additional secondary current mode feedback loop improves transient response in a manner similar to primary current mode control and allows for ease of paralleling, but without the cost and complexity.

The constant frequency, pulse-width modulated converters use a quasi-square wave single-ended forward design. Tight load regulation is achieved through a wide-bandwidth magnetic feedback circuit. The output on single MFL models can be trimmed (see Figure 1 for voltage changes with different resistor values).

INHIBIT

The MFL Series converters have two inhibit terminals (INH1 and INH2) that can be used to disable power conversion, resulting in a very low quiescent input current and no generation of switching noise. See the following page for inhibit specifications.

SYNC

Converters may be synced to an external clock (525 to 675 kHz) or to one another by using the sync in or out pins. The nominal free-run switching frequency is 600 kHz.

CURRENT SHARE AND PARALLEL OPERATION

Multiple MFL converters may be used in parallel to drive a common load (see Figure 2). Only single output models with SENSE and SNS RTN can be used in the share mode. In this mode of operation the load current is shared by two or three MFL converters. In current sharing mode, one MFL converter is designated as a master. The SLAVE pin (pin 11) of the master is left unconnected and the MSTR/INH2 pin (pin 12) of the master is connected to the SLAVE pin (pin 11) of the slave units. The units designated as slaves have the MSTR/INH2 pin (pin 12) connected to the SNS RTN pin (pin 9). Figure 2 shows the typical setup for two or three units in parallel. Note that synchronizing the units together (though shown in the figure) is not required for current sharing operation. A second slave unit may be placed in parallel with a master and slave; this requires the TRI pin (pin 3) of the master unit to be connected to the SNS RTN pin (pin 9).

When paralleled, up to 95% of the total combined power ratings of the MFL converters is available at the load. Overload and short circuit performance are not adversely affected during parallel operation.

MFL Single and Dual DC/DC Converters

28 VOLT INPUT – 65 WATT

OPERATING CONDITIONS AND CHARACTERISTICS

Input Voltage Range

- 16 to 40 VDC continuous
- 19 to 40 VDC for the MFL2828S
- 50 V for 50 msec transient

Output Power

- 40 to 65 watts depending on model

Lead Soldering Temperature (10 sec per lead)

- 300°C

Storage Temperature Range (Case)

- -65°C to +150°C

Case Operating Temperature (Tc)

- -55°C to +125°C full power
- MFL283R3S: -55°C to +100°C full power
- -55°C to +135°C absolute

Derate Output Power/Current

- Linearly from 100% at 125°C to 0% at 135°C
- MFL283R3S:
linearly from 100% at 100°C to 0% at 135°C

Output Voltage Temperature Coefficient

- 100 ppm/°C typical

Input to Output Capacitance

- 150 pF, typical

Current Limit

- 125% of full load typical

Isolation

- 100 megohm minimum at 500 V

Audio Rejection

- 50 dB typical

Conversion Frequency (-55°C to 125°C)

- Free run mode 600 kHz typical
525 kHz. min, 675 kHz max

SYNC AND INHIBIT (INH1, INH2)

Sync

- Sync In
 - Input frequency 525 to 675 Hz.
 - Duty cycle 40% min, 60% max
 - Active low 0.8 V max
 - Active high 4.5 V min, 5 V max
 - Referenced to input common
- Sync Out
 - Referenced to input common

Inhibit: INH1 and INH2

(do not apply a voltage to the inhibit pin)

- Converter Disabled (active low)
 - INH1 referenced to input common
 - Pull voltage to 0.8 V or below by connecting to ground or other method.
 - Inhibit pin source current, 10 mA max
 - INH2 referenced to output common
 - Pull voltage to 0.5 V or below by connecting to ground or other method.
 - Inhibit pin source current 5 mA max
- Converter Enabled (active high)
 - Inhibit pin open or through an open collector
 - Open pin voltage
 - INH1 = 9 to 12 V
 - INH2 = 9 V max

MECHANICAL AND ENVIRONMENTAL

Size (maximum)

- 3.005 x 1.505 x 0.400 inches (76.33 x 38.23 x 10.16 mm)
- See figure 17, case U, for dimensions.

Weight (maximum)

- 86 grams

Screening

- Standard, ES, or /883 (Class H, QML).
- See Screening Tables 1 and 2 for more information.

MFL Single and Dual DC/DC Converters

28 VOLT INPUT – 65 WATT

SINGLE OUTPUT MODELS CONNECTION DIAGRAMS - SENSE AND PARALLEL

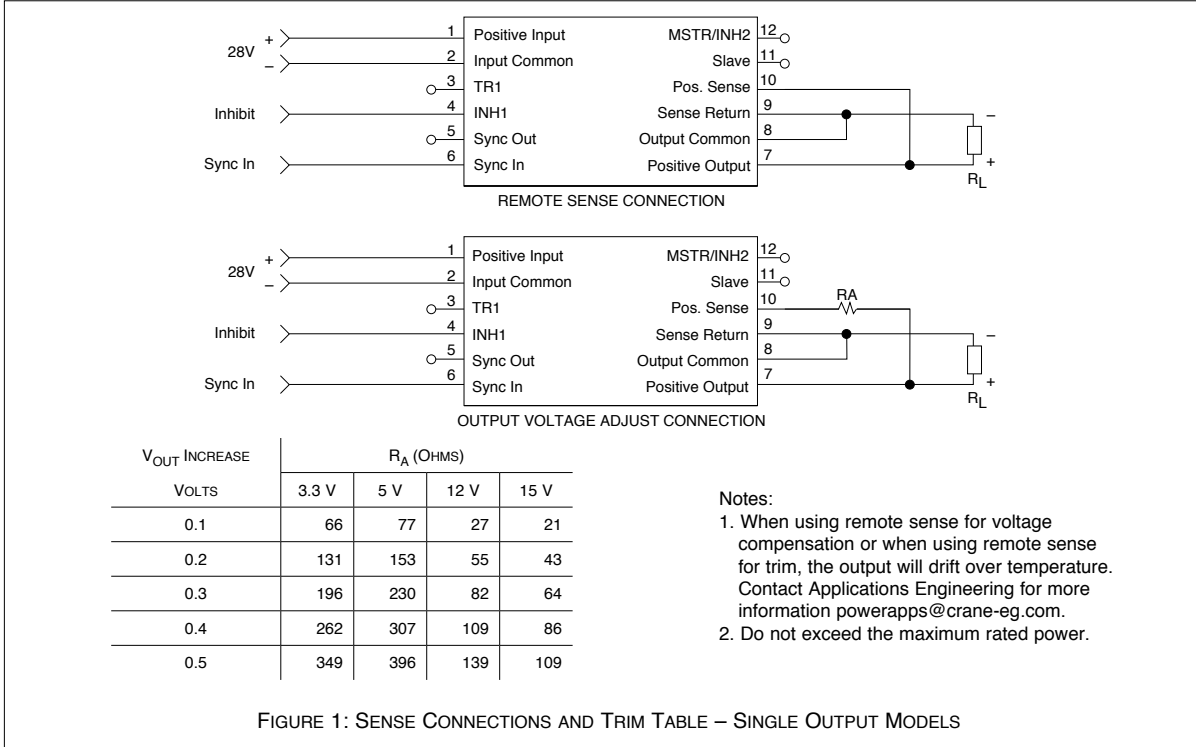

FIGURE 1: SENSE CONNECTIONS AND TRIM TABLE – SINGLE OUTPUT MODELS

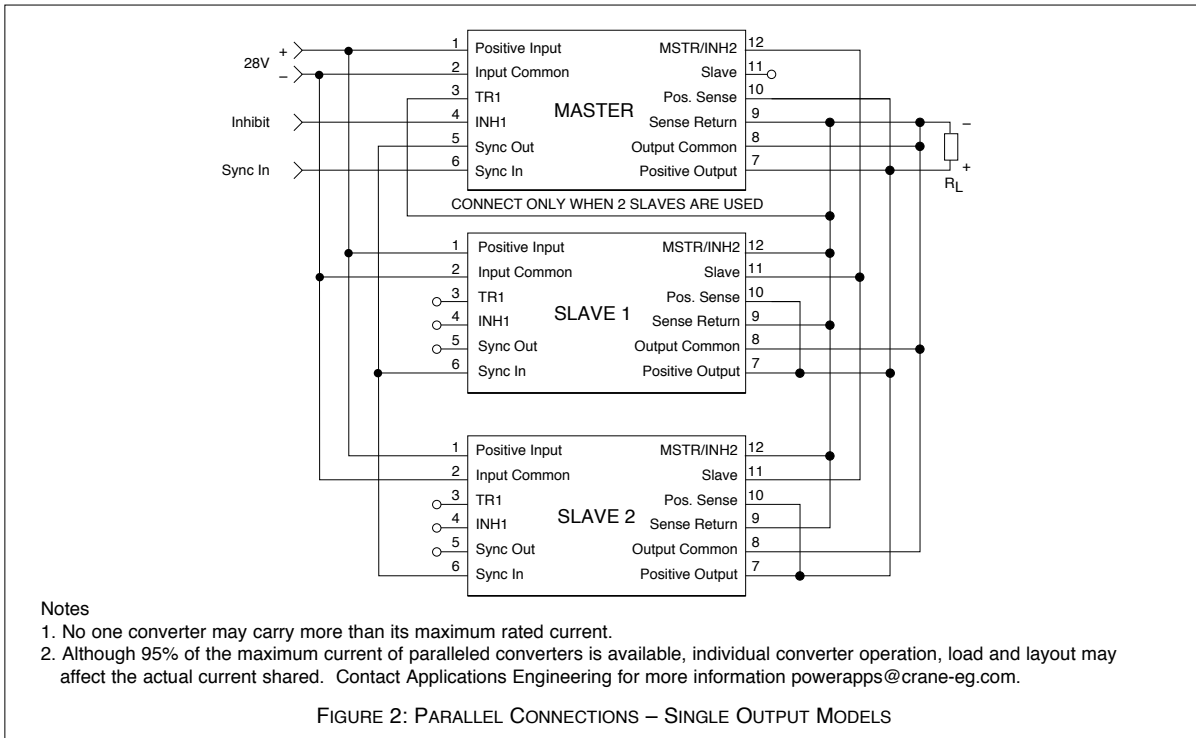

FIGURE 2: PARALLEL CONNECTIONS – SINGLE OUTPUT MODELS

MFL Single and Dual DC/DC Converters

28 VOLT INPUT – 65 WATT

PIN OUT

PIN OUT			
Pin	Single Output	MFL2828S only	Dual Output
1	Positive Input	Positive Input	Positive Input
2	Input Common	Input Common	Input Common
3	Triple (TR1)	Triple (TR1)	Triple (TR1)
4	Inhibit 1 (INH1)	Inhibit 1 (INH1)	Inhibit 1 (INH1)
5	Sync Out	Sync Out	Sync Out
6	Sync In	Sync In	Sync In
7	Positive Output	Positive Output	Positive Output
8	Output Common	No connection	Output Common
9	Sense Return	Output Common	Negative Output
10	Positive Sense	No connection	No connection
11	Slave	Slave	Slave
12	Master/Inhibit 2 (MSTR/INH2)	Master/Inhibit 2 (MSTR/INH2)	Master/Inhibit 2 (MSTR/INH2)

PINS NOT IN USE		
Pin	Description	Action
3	TR1	Leave unconnected
4	Inhibit 1 (INH1)	Leave unconnected
5	Sync Out	Leave unconnected
6	Sync In	Connect to Input Common
9	Sense Return	Connect to Output Common
10	Positive Sense	Connect to Positive Output
11	Slave	Leave unconnected
12	Master/Inhibit 2 (MSTR/INH2)	Leave unconnected

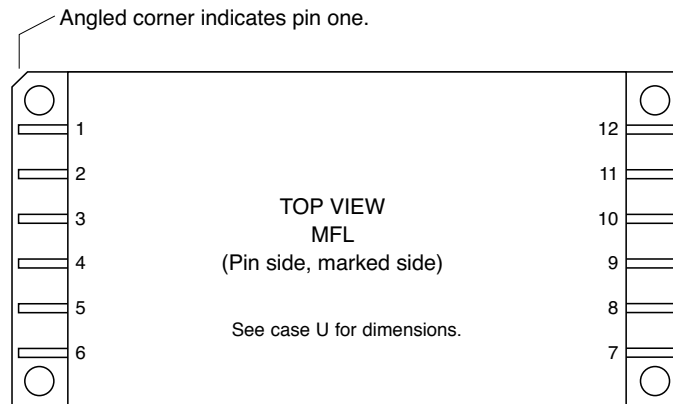
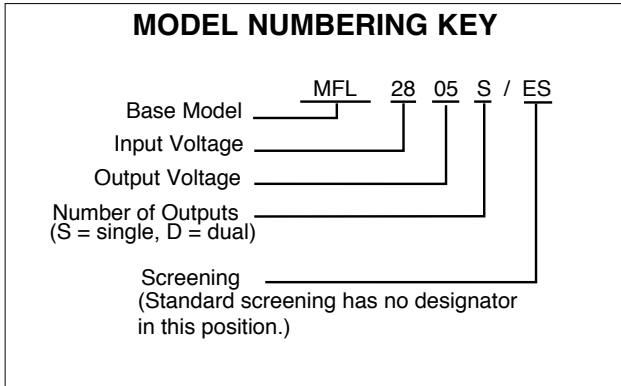

FIGURE 3: PIN OUT

MFL Single and Dual DC/DC Converters

28 VOLT INPUT – 65 WATT



SMD NUMBERS

STANDARD MICROCIRCUIT DRAWING (SMD)	MFL SERIES SIMILAR PART
5962-0621301HXC	MFL283R3S/883
5962-9316301HXC	MFL2805S/883
5962-9316201HXC	MFL2812S/883
5962-9316101HXC	MFL2815S/883
5962-9319101HXC	MFL2805D/883
5962-9319301HXC	MFL2812D/883
5962-9319201HXC	MFL2815D/883

For exact specifications for an SMD product, refer to the SMD drawing. SMDs can be downloaded from: <http://www.dsccl.dla.mil/programs/smcr>

MODEL SELECTION

ON THE LINES BELOW, ENTER ONE SELECTION FROM EACH CATEGORY TO DETERMINE THE MODEL NUMBER.

CATEGORY	MFL28 Base Model and Input Voltage	_____	_____	/	_____
		Output Voltage ¹	Number of Outputs ²		Screening ³
SELECTION	MFL28 is the only available option	3R3, 05, 12, 15, 28	S		(STANDARD leave blank)
		05, 12, 15	D		ES 883

- Notes:
- Output Voltage: An R indicates a decimal point. 3R3 is 3.3 volts out.
 - Number of Outputs: S is a single output and D is a dual output
 - Screening: For standard screening leave the screening option blank. For other screening options, insert the desired screening level. For more information see Screening Tables 1 and 2

MFL Single and Dual DC/DC Converters

28 VOLT INPUT – 65 WATT

Electrical Characteristics: -55°C to +125°C T_C , 28 VDC V_{IN} , 100% load, free run, unless otherwise specified.

SINGLE OUTPUT MODELS		MFL283R3S			MFL2805S			MFL2812S			UNITS
PARAMETER	CONDITIONS	MIN	TYP	MAX	MIN	TYP	MAX	MIN	TYP	MAX	
OUTPUT VOLTAGE		3.21	3.30	3.39	4.87	5.00	5.13	11.76	12.00	12.24	VDC
OUTPUT CURRENT	$V_{IN} = 16$ TO 40 VDC	0	—	12.12 ²	0	—	10	0	—	5	A
OUTPUT POWER	$V_{IN} = 16$ TO 40 VDC	0	—	40 ²	0	—	50	0	—	60	W
OUTPUT RIPPLE	$T_C = 25^\circ\text{C}$	—	10	35	—	15	35	—	30	75	mV p-p
10 kHz - 2 MHz	$T_C = -55^\circ\text{C}$ TO $+125^\circ\text{C}$	—	10	50	—	30	50	—	45	100	
LINE REGULATION	$V_{IN} = 16$ TO 40 VDC	—	0	20	—	0	20	—	0	20	mV
LOAD REGULATION	NO LOAD TO FULL	—	—	40	—	—	20	—	—	20	mV
INPUT VOLTAGE	CONTINUOUS	16	28	40	16	28	40	16	28	40	VDC
NO LOAD TO FULL	TRANSIENT 50 msec. ^{1, 3}	—	—	50	—	—	50	—	—	50	V
INPUT CURRENT	NO LOAD	—	70	100	—	70	120	—	50	100	mA
	INHIBITED–INH1	—	9	14	—	9	14	—	9	14	
	INHIBITED–INH2	—	35	70	—	35	70	—	35	70	
INPUT RIPPLE CURRENT	10 kHz - 10 MHz	—	15	50	—	15	50	—	15	50	mA p-p
EFFICIENCY	$T_C = 25^\circ\text{C}$	73	—	—	77	80	—	83	86	—	%
	$T_C = -55^\circ\text{C}$ TO $+125^\circ\text{C}$	71	—	—	75	—	—	81	—	—	
LOAD FAULT	POWER DISSIPATION SHORT CIRCUIT	—	12.5	16	—	12.5	18	—	10	16	W
	RECOVERY ¹	—	1.5	6	—	1.5	4	—	1.5	4	ms
STEP LOAD RESPONSE	50% - 100% - 50% TRANSIENT	—	200	300	—	250	350	—	450	600	mV pk
	RECOVERY ^{1, 4}	—	1.5	3.0	—	1.5	3.0	—	1.5	3.0	ms
STEP LINE RESPONSE ¹	16 - 40 - 16 VDC TRANSIENT ⁵	—	250	300	—	250	300	—	250	400	mV pk
	RECOVERY ⁴	—	200	600	—	200	300	—	200	300	μs
START-UP ⁷	DELAY	—	3.5	6	—	3.5	6	—	3.5	6	ms
	OVERSHOOT ¹	—	0	25	—	0	25	—	0	25	mV pk
CAPACITIVE LOAD ^{1, 6}	$T_C = 25^\circ\text{C}$	—	—	1000	—	—	1000	—	—	1000	μF

Notes

1. Guaranteed by design, not tested.

2. MFL283R3S current and power maximums are specified at 25°C only.

3. Unit will shut down above approximately 45V but will be undamaged and will restart when voltage drops into normal range.

4. Recovery time is measured from application of the transient to the point at which V_{out} is within 1% of final value.

5. Transition time 100 μs $\pm 20\%$.

6. Tested on release from inhibit.

7. Shall not compromise DC performance.

MFL Single and Dual DC/DC Converters

28 VOLT INPUT – 65 WATT

Electrical Characteristics: -55°C to +125°C T_C, 28 VDC V_{IN}, 100% load, free run, unless otherwise specified.

SINGLE OUTPUT MODELS		MFL2815S			MFL2828S			UNITS
PARAMETER	CONDITIONS	MIN	TYP	MAX	MIN	TYP	MAX	
OUTPUT VOLTAGE		14.55	15.00	15.45	27.16	28.00	28.84	VDC
OUTPUT CURRENT	V _{IN} = 16 TO 40 VDC	0	—	4.33	0	—	2.32	A
OUTPUT POWER	V _{IN} = 16 TO 40 VDC	0	—	65	0	—	65	W
OUTPUT RIPPLE 10 kHz - 2 MHz	T _C = 25°C	—	30	85	—	100	200	mV p-p
	T _C = -55°C TO +125°C	—	45	110	—	—	275	
LINE REGULATION	V _{IN} = 16 TO 40 VDC	—	0	20	—	20	60	mV
LOAD REGULATION	NO LOAD TO FULL	—	0	20	—	20	75	mV
INPUT VOLTAGE NO LOAD TO FULL	CONTINUOUS	16	28	40	16 ²	28	40	VDC
	TRANSIENT 50 msec. ^{1, 3}	—	—	50	—	—	50	V
INPUT CURRENT	NO LOAD	—	50	100	—	60	100	mA
	INHIBITED-INH1	—	9	14	—	9	14	
	INHIBITED-INH2	—	35	70	—	35	70	
INPUT RIPPLE CURRENT	10 kHz - 10 MHz	—	15	50	—	20	50	mA p-p
EFFICIENCY	T _C = 25°C	84	87	—	83	86	—	%
	T _C = -55°C TO +125°C	82	—	—	81	—	—	
LOAD FAULT	POWER DISSIPATION SHORT CIRCUIT T _C = 25°C	—	10	16	—	7	14	W
	RECOVERY ¹	—	1.5	4	—	1.0	4	ms
STEP LOAD RESPONSE	50% - 100% - 50% TRANSIENT	—	500	600	—	800	1400	mV pk
	RECOVERY ^{1, 4}	—	1.5	3.0	—	1.5	3.0	ms
STEP LINE RESPONSE ¹	16 - 40 - 16 VDC TRANSIENT ⁵	—	250	500	—	250	800	mV pk
	RECOVERY ⁴	—	200	300	—	200	400	μs
START-UP ^{2, 6}	DELAY	—	3.5	6	—	3.5	6	ms
	OVERSHOOT ¹	—	0	50	—	0	100	mV pk
CAPACITIVE LOAD ^{1, 7}	T _C = 25°C	—	—	1000	—	—	1000	μF

Notes

1. **Guaranteed by design, not tested.**

2. MFL2828S will operate at 16 VDC in but requires 19 VDC in to start.

3. Unit will shut down above approximately 45V but will be undamaged and will restart when voltage drops into normal range.

4. Recovery time is measured from application of the transient to the point at which V_{out} is within 1% of final value.

5. Transition time 100 μs ±20%.

6. Tested on release from inhibit.

7. Shall not compromise DC performance.

MFL Single and Dual DC/DC Converters

28 VOLT INPUT – 65 WATT

Electrical Characteristics: -55°C to +125°C T_C, 28 VDC V_{IN}, 100% load, free run, unless otherwise specified.

DUAL OUTPUT MODELS ²		MFL2805D			MFL2812D			MFL2815D			UNITS
PARAMETER	CONDITIONS	MIN	TYP	MAX	MIN	TYP	MAX	MIN	TYP	MAX	
OUTPUT VOLTAGE	+ V _{OUT}	4.85	5.00	5.15	11.64	12.00	12.36	14.55	15.00	15.45	VDC
	- V _{OUT}	4.82	5.00	5.18	11.58	12.00	12.42	14.47	15.00	15.53	
OUTPUT CURRENT ³ V _{IN} = 16 TO 40 VDC	EACH OUTPUT	0	—	7	0	—	3.5	0	—	3.03	A
	TOTAL OUTPUT	0	—	10	0	—	5	0	—	4.34	
OUTPUT POWER ³	V _{IN} = 16 TO 40 VDC	0	—	50	0	—	60	0	—	65	W
OUTPUT RIPPLE	10 kHz - 2 MHz ± V _{OUT}	—	50	100	—	50	120	—	50	150	mV p-p
LINE REGULATION V _{IN} = 16 TO 40 VDC	+ V _{OUT}	—	0	50	—	0	50	—	0	50	mV
	- V _{OUT}	—	25	100	—	25	100	—	25	100	
LOAD REGULATION NO LOAD TO FULL	+ V _{OUT}	—	0	50	—	10	50	—	10	50	mV
	- V _{OUT}	—	25	100	—	25	120	—	50	150	
CROSS REGULATION T _C = 25°C	SEE NOTE 4	—	5	8	—	2	4	—	2	4	%
	SEE NOTE 5	—	3	7	—	2	4	—	2	4	
INPUT VOLTAGE	CONTINUOUS	16	28	40	16	28	40	16	28	40	VDC
NO LOAD TO FULL	TRANSIENT 50 msec. ^{1, 6}	0	—	50	0	—	50	0	—	50	V
INPUT CURRENT	NO LOAD	—	50	120	—	50	100	—	50	100	mA
	INHIBITED–INH1	—	9	14	—	9	14	—	9	14	
	INHIBITED–INH2	—	35	70	—	35	70	—	35	70	
INPUT RIPPLE CURRENT	10 kHz - 10 MHz	—	15	50	—	15	50	—	15	50	mA p-p
EFFICIENCY BALANCED LOAD	T _C = 25°C	77	80	—	83	86	—	84	87	—	%
	T _C = -55°C TO +125°C	75	—	—	81	—	—	82	—	—	
LOAD FAULT	POWER DISSIPATION SHORT CIRCUIT	—	12.5	18	—	10	16	—	10	16	W
	RECOVERY ¹	—	1.5	4	—	1.5	4	—	1.5	4.0	ms
STEP LOAD RESPONSE ⁷ ± V _{OUT}	50% - 100% - 50% TRANSIENT	—	250	350	—	450	600	—	500	600	mV pk
	RECOVERY ^{1, 8}	—	1.5	3.0	—	1.5	3.0	—	1.5	3.0	ms
STEP LINE RESPONSE ^{1, 7} ± V _{OUT}	16 - 40 - 16 VDC TRANSIENT	—	250	300	—	250	400	—	250	500	mV pk
	RECOVERY ⁸	—	200	300	—	200	300	—	200	300	μs
START-UP ⁹	DELAY	—	3.5	6	—	3.5	6	—	3.5	6	ms
	OVERSHOOT ¹	—	0	25	—	0	50	—	0	50	mV pk
CAPACITIVE LOAD ^{1, 10}	T _C = 25°C	—	—	500	—	—	500	—	—	500	μF

Notes:

1. Guaranteed by design, not tested.
2. Parallel load share function is not characterized for dual output models.
3. Up to 70% of the total output power is available from either output providing the opposite output is simultaneously carrying 30% of the total power.
4. Effect on negative Vout from 50%/50% loads to 70%/30% or 30%/70% loads.
5. Effect on negative Vout from 50%/50% loads to 50% then 10% load on negative Vout.
6. Unit will shut down above approximately 45V but will be undamaged and will restart when voltage drops into normal range.
7. Transition time 100 μs ±20%.
8. Recovery time is measured from application of the transient to point at which Vout is within 1% of final value.
9. Tested on release from inhibit.
10. Shall not compromise DC performance.

MFL Single and Dual DC/DC Converters

28 VOLT INPUT – 65 WATT

Typical Performance Curves: 25°C T_C, 28 VDC V_{IN}, 100% load, free run, unless otherwise specified.

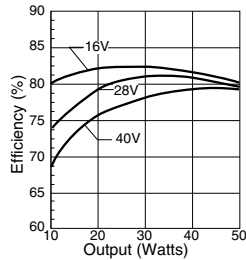

MFL2805S & MFL2805D Efficiency
FIGURE 4

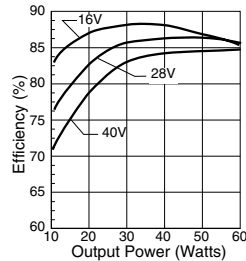

MFL2812S & MFL2812D Efficiency
FIGURE 5

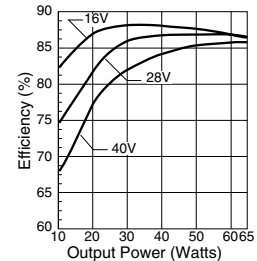

MFL2815S & MFL2815D Efficiency
FIGURE 6

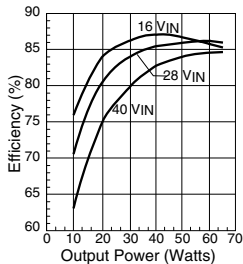

MFL2828S Efficiency
FIGURE 7

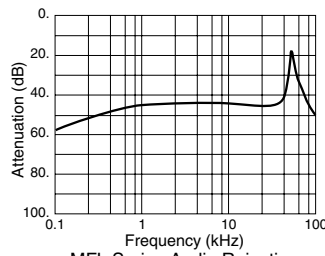

MFL Series Audio Rejection
FIGURE 8

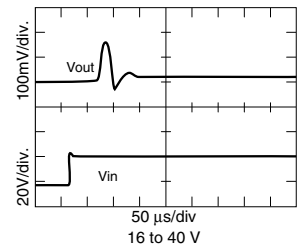

MFL2805S Step Line Response
FIGURE 9

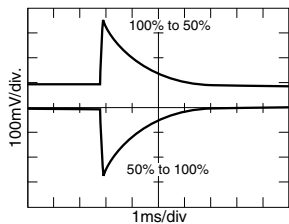

MFL2805S Step Load Response
FIGURE 10

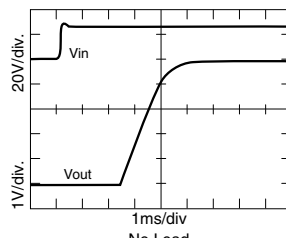

MFL2805S Turn On Response
FIGURE 11

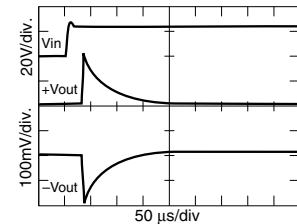

MFL2815D Step Line Response
FIGURE 12

MFL Single and Dual DC/DC Converters

28 VOLT INPUT – 65 WATT

Typical Performance Curves: 25°C Tc , 28 VDC Vin, 100% load, free run, unless otherwise specified.

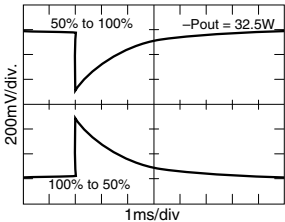

MFL2815D Step Load Response

FIGURE 13

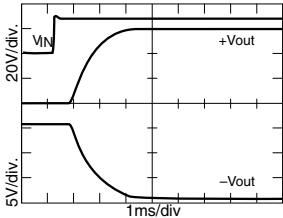

MFL2815D Turn On Response

FIGURE 14

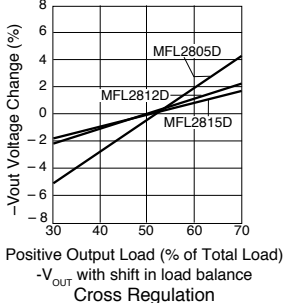

FIGURE 15

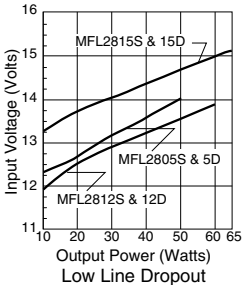
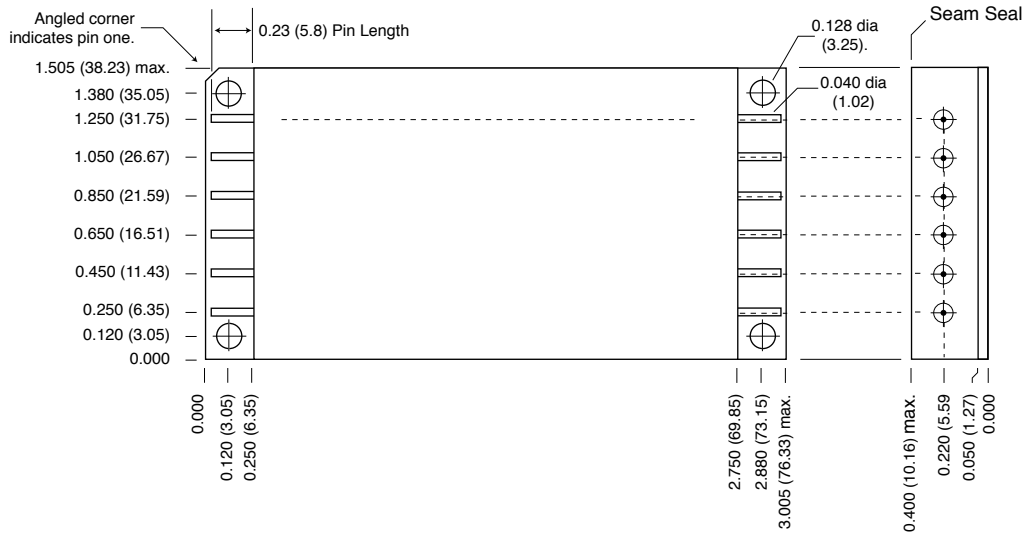

FIGURE 16

MFL Single and Dual DC/DC Converter Cases

28 VOLT INPUT – 65 WATT

TOP VIEW CASE U Flanged case, short-leaded



Case dimensions in inches (mm)

Tolerance ± 0.005 (0.13) for three decimal places
 ± 0.01 (0.3) for two decimal places
 unless otherwise specified

CAUTION

Heat from reflow or wave soldering may damage the device. Solder pins individually with heat application not exceeding 300°C for 10 seconds per pin.

Materials

Header Cold Rolled Steel/Nickel/Gold
 Cover Kovar/Nickel
 Pins #52 alloy/Gold, compression glass seal
 Seal Hole: 0.100 \pm 0.002 (2.54 \pm 0.05)

Case U, Rev F, 20100915

FIGURE 17: CASE U

MFL Single and Dual DC/DC Converters

28 VOLT INPUT – 65 WATT

STANDARD AND /ES (NON-QML) AND /883 (CLASS H, QML) MIL-PRF-38534 ELEMENT EVALUATION

COMPONENT-LEVEL TEST PERFORMED	NON-QML	QML	
	STANDARD AND /ES	CLASS H /883	
	M/S ²	M/S ²	P ³
Element Electrical	■	■	■
Visual		■	■
Internal Visual		■	
Final Electrical		■	■
Wire Bond Evaluation		■	■

Notes:

1. Non-QML products may not meet all of the requirements of MIL-PRF-38534.
2. M/S = Active components (Microcircuit and Semiconductor Die)
3. P = Passive components, Class H element evaluation. Not applicable to Standard and /ES element evaluation.

SCREENING TABLE 1: ELEMENT EVALUATION

MFL Single and Dual DC/DC Converters

28 VOLT INPUT – 65 WATT

STANDARD AND /ES (NON-QML) AND /883 (CLASS H, QML) MIL-PRF-38534 ENVIRONMENTAL SCREENING

TEST PERFORMED	NON-QML ¹		QML
	STANDARD	/ES	/883
Pre-cap Inspection, Method 2017, 2032	■	■	■
Temperature Cycle (10 times)			
Method 1010, Cond. C, -65°C to +150°C, ambient			■
Method 1010, Cond. B, -55°C to +125°C, ambient		■	
Constant Acceleration			
Method 2001, 3000 g			■
Method 2001, 500 g		■	
Burn-in Method 1015, +125°C case, typical ²			
96 hours		■	
160 hours			■
Final Electrical Test, MIL-PRF-38534, Group A,			
Subgroups 1 through 6, -55°C, +25°C, +125°C case			■
Subgroups 1 and 4, +25°C case	■	■	■
Hermeticity Test			
Gross Leak, Method 1014, Cond. C		■	■
Fine Leak, Method 1014, Cond. A		■	■
Gross Leak, Dip	■		
Final visual inspection, Method 2009	■	■	■

Test methods are referenced to MIL-STD-883 as determined by MIL-PRF-38534.

Notes:

- Standard and /ES, non-QML products, may not meet all of the requirements of MIL-PRF-38534.
- Burn-in temperature designed to bring the case temperature to +125°C minimum. Burn-in is a powered test.

SCREENING TABLE 2: ENVIRONMENTAL SCREENING