

CAS

SLIDE SWITCHES (SMD)

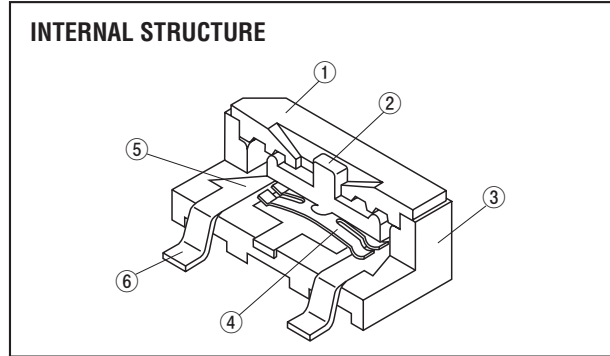
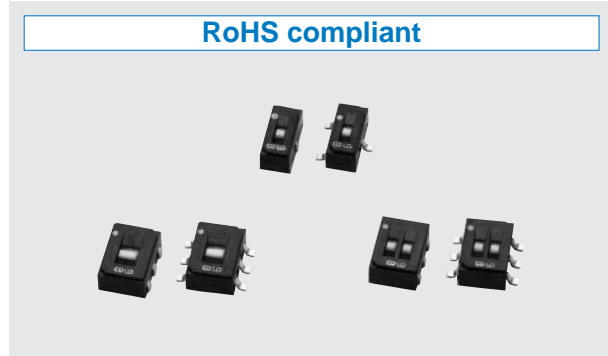

FEATURES

- RoHS compliant
- Compatible with most automatic pick & place machinery
- Compact and space saving SMD type
- Excellent contact stability by twin Gold-plated contact
- Low profile design of 2.5 mm

Part name	Material	Flammability
① Cover	PPS(Polyphenylenesulphide)	UL-94V-0
② Slider	PA(Polyamide)	
③ Housing	PPS(Polyphenylenesulphide)	
④ Slider contact	Copper alloy, Gold-plated	—
⑤ Fixed contact		
⑥ Terminal pin		

PART NUMBER DESIGNATION

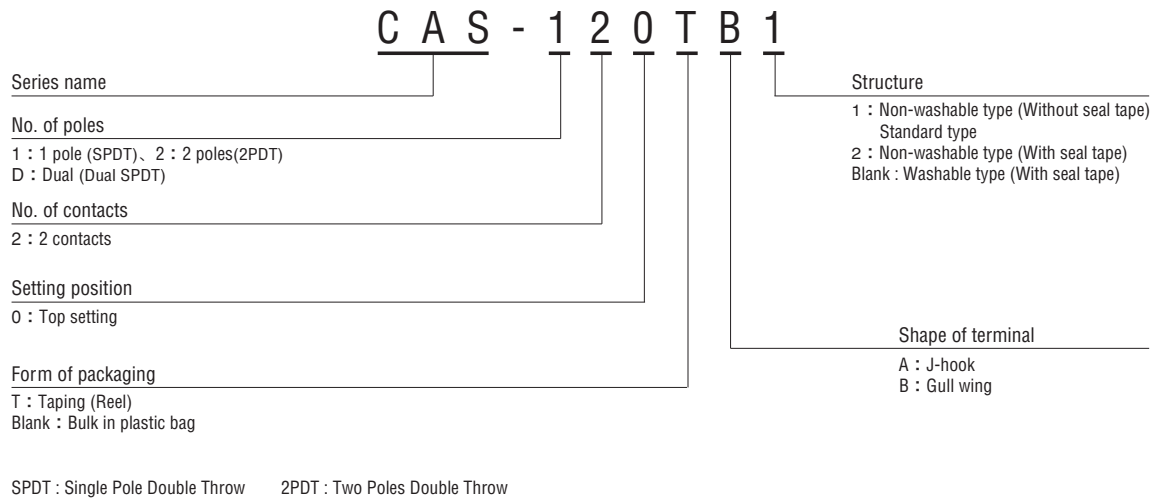

※ Please refer to the LIST OF PART NUMBERS when placing orders.

LIST OF PART NUMBERS

No. of poles	No. of contacts	Setting position	Form of packaging	Non-washable type (Without seal tape)		Non-washable type (With seal tape)		Pieces in package
				A (J-hook)	B (Gull wing)	A (J-hook)	B (Gull wing)	
1	2	Top setting	Taping	CAS-120TA1	CAS-120TB1	CAS-120TA2	CAS-120TB2	1000pcs./reel
			Plastic bag	CAS-120A1	CAS-120B1	CAS-120A2	CAS-120B2	100pcs./pack
2			Taping	CAS-220TA1	CAS-220TB1	CAS-220TA2	CAS-220TB2	1000pcs./reel
			Plastic bag	CAS-220A1	CAS-220B1	CAS-220A2	CAS-220B2	100pcs./pack
Dual			Taping	CAS-D20TA1	CAS-D20TB1	CAS-D20TA2	CAS-D20TB2	1000pcs./reel
			Plastic bag	CAS-D20A1	CAS-D20B1	CAS-D20A2	CAS-D20B2	100pcs./pack

No. of poles	No. of contacts	Setting position	Form of packaging	Washable type (With seal tape)		Pieces in package
				A (J-hook)	B (Gull wing)	
1	2	Top setting	Taping	CAS-120TA	CAS-120TB	1000pcs./reel
			Plastic bag	CAS-120A	CAS-120B	100pcs./pack
2			Taping	CAS-220TA	CAS-220TB	1000pcs./reel
			Plastic bag	CAS-220A	CAS-220B	100pcs./pack
Dual			Taping	CAS-D20TA	CAS-D20TB	1000pcs./reel
			Plastic bag	CAS-D20A	CAS-D20B	100pcs./pack

※ Verify the above part numbers when placing orders.
Taping version can be supplied only in reel unit.

■ **STANDARD SPECIFICATIONS**

Operating temp. range	- 40 ~ 85 °C
Storage temp. range	
Sealing	Washable type available with seal tape
Net weight	Approx. 0.05g (CAS-120) Approx. 0.08g (CAS-220/D20)

■ **ELECTRICAL CHARACTERISTICS**

Contact rating Non-switching Switching Minimum	DC50 V 100 mA DC6 V, 100 mA DC24 V, 25 mA DC20 mV 1 μA
Contact resistance	50 mΩ maximum
Insulation resistance	1000 MΩ (DC100 V) minimum
Dielectric strength	AC500 V, 60 s

■ **MECHANICAL CHARACTERISTICS**

Operating force	0.5 ~ 5 N {0.05 ~ 0.51 kgf}
Stop strength	10 N {1.02 kgf}, 60 s
Solderability	245 ± 3 °C, 2 ~ 3 s
Soldering heat	Reflow : 255 °C (Peak temperature) (Please refer to the profile below)
	Manual soldering : 350 ± 10 °C, 3 ~ 4 s
Shear (Adhesion)	5 N {0.51 kgf} 10 s
Substrate bending	Width 90 mm, bend 3 mm, 5 s, 1 time
Pull-off strength	5 N {0.51 kgf} 10 s

■ **ENVIRONMENTAL CHARACTERISTICS**

Vibration	Amplitude 1.5 mm or Acceleration 98 m/s ² , 10-500 Hz, 3 directions for 10 cycles each
Shock	490 m/s ² , 11 ms 6 directions for 3 times each
Load life	Continuous load 2000 cycles, DC6 ± 0.5 V, 100 ± 10 mA
Humidity	-10 ~ 65 °C, Relative humidity 0 ~ 96 %, 24 h for 10 cycles
High temp. exposure	85 °C, 96 h
Low temp. exposure	-40 °C, 96 h
Thermal shock	-40 (0.5 h) ~ 85 °C (0.5 h), 5 cycles

{ } : Reference only

〈Reflow profile for soldering heat evaluation〉

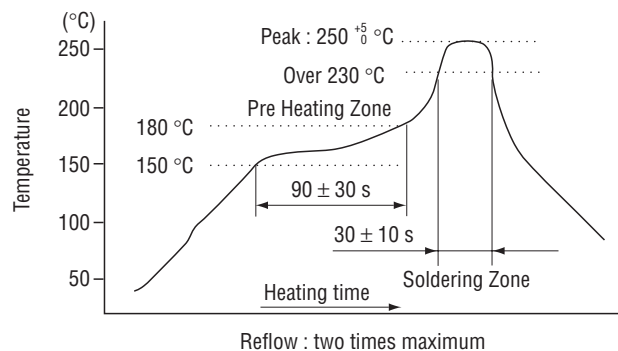

CAS
SLIDE SWITCHES (SMD)

OUTLINE DIMENSIONS

Unless otherwise specified, tolerance : ± 0.3 (Unit : mm)

CAS-120A1

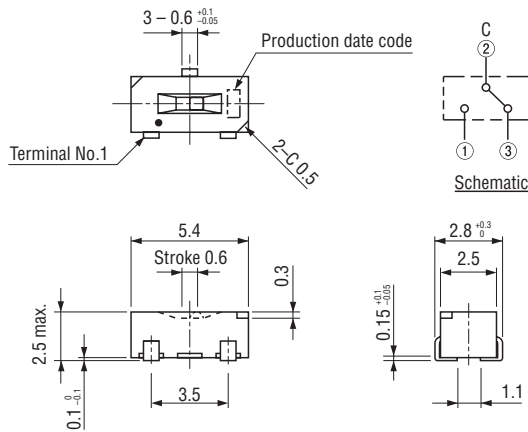

CAS-120B1

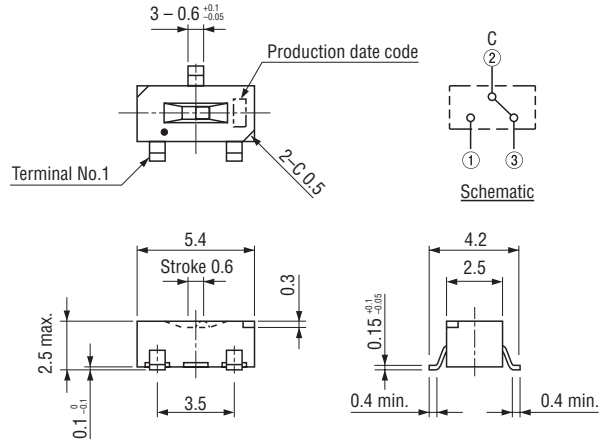

CAS-220A1

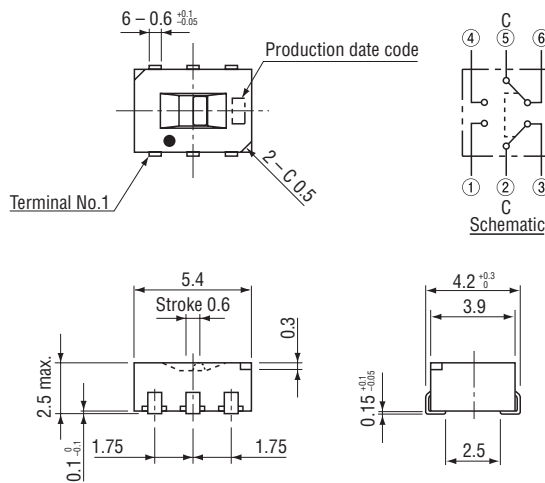

CAS-220B1

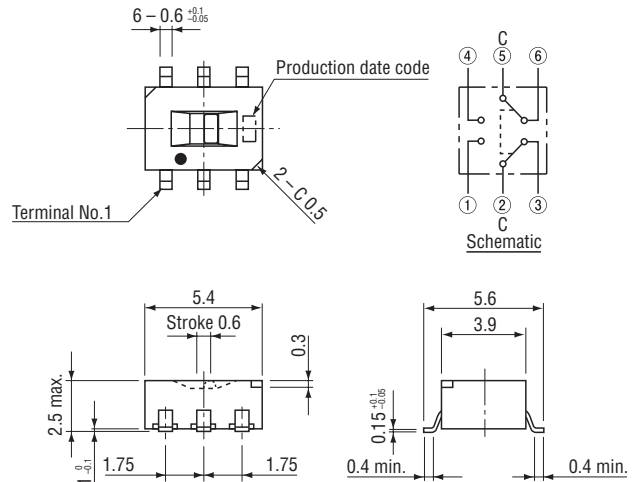

CAS-D20A1

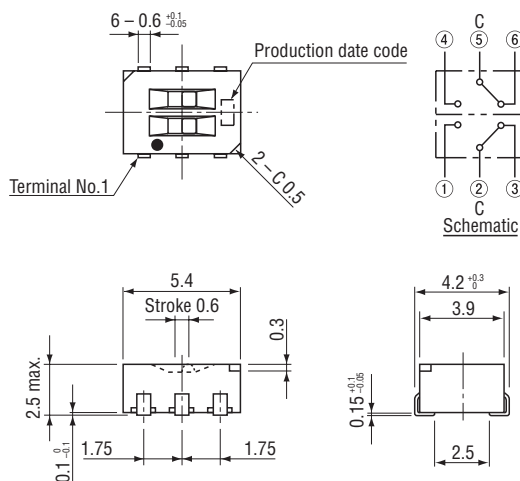

CAS-D20B1

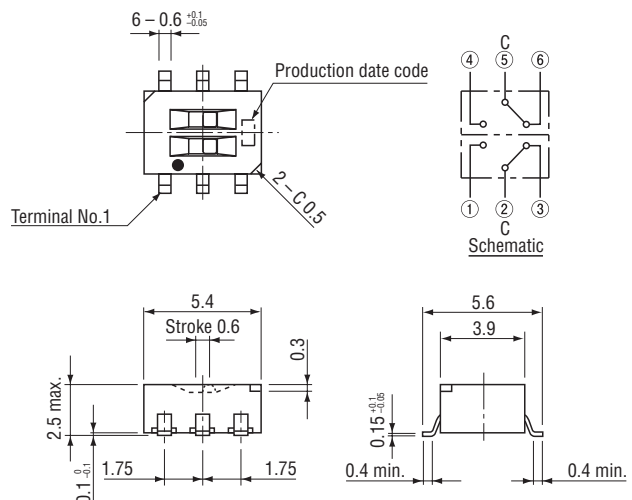

Specifications are subject to change without notice. Specifications in this catalog are for reference. The formal specification sheets will be submitted upon request.

RECOMMENDED P.C.B. PAD OUTLINE DIMENSIONS

● **CAS-120**

(Unit : mm)

A type

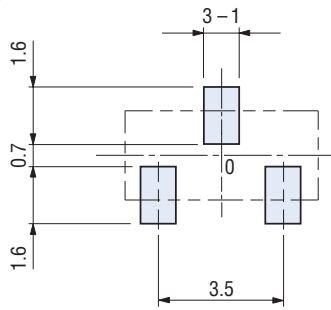

B type

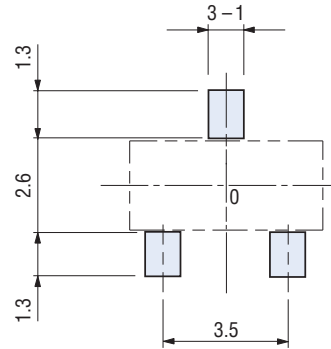

● **CAS-220 • D20**

A type

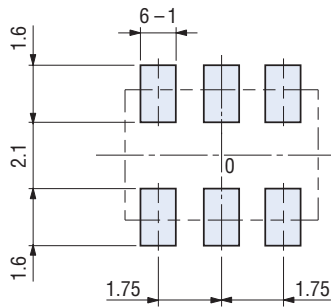

B type

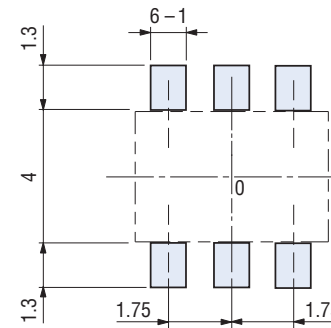

Note) The zero point is the center of mounting.

PACKAGING SPECIFICATIONS

<Taping packaging specifications>

- Taping version is packaged in 1000 pcs. per reel.
Orders will be accepted for units of 1000 pcs., i.e., 1000, 2000, 3000 pcs., etc.
- Taping version is boxed with two reels (2000 pcs.).

Maximum number of consecutive missing pieces=2
Leader length and reel dimension are shown in the diagrams below:

● Embossed tape dimensions

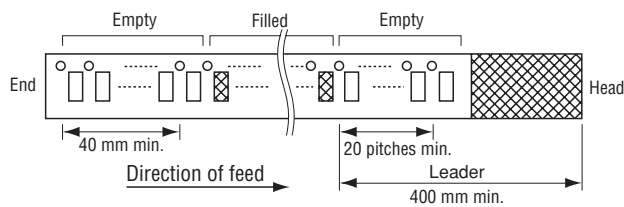

● Reel dimensions

(Unit: mm)
(Conforms to JIS C 0806-3)

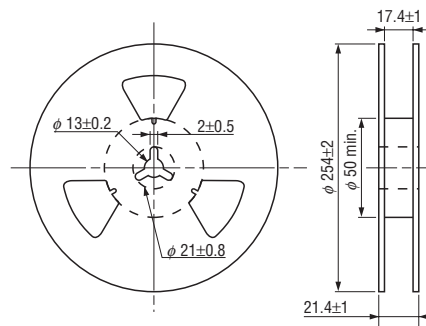

● CAS-120TA, TB

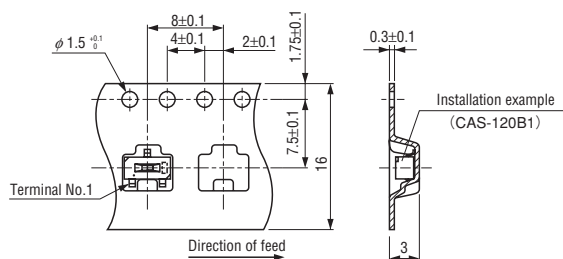

● CAS-220TA, TB • D20TA, TB

(Unit: mm)
(Conforms to JIS C 0806-3)
(In accordance with EIAJ ET-7200A)

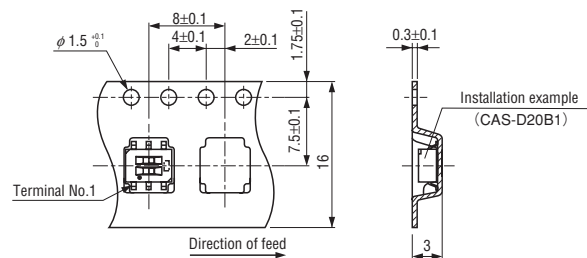

<Bulk pack specifications>

- Boxing of bulk pack in a plastic bag is performed with 100 pcs. (standard 500 pcs.) per box.