

TITLE : HX121WX1-101

Product Specification

For customer

Rev. A

FOR MORE INFORMATION:

AZ DISPLAYS, INC.

75 COLUMBIA, ALISO VIEJO, CA 92656

[Http://www.AZDISPLAYS.com](http://www.AZDISPLAYS.com)

HYDIS Technologies

SPEC. NUMBER	PRODUCT GROUP	REV.	ISSUE DATE	PAGE
S864-1366	TFT LCD	A	2009. 02. 10	1 OF 33

Contents

No	Item	Page
1.0	General Description	4
2.0	Absolute Maximum Ratings	6
3.0	Electrical Specifications	7
4.0	Optical Specifications	9
5.0	Interface Connections	14
6.0	Signal Timing Specifications	17
7.0	Signal Timing Waveforms	17
8.0	Input Signals, Basic Display Colors & Gray Scale of Colors	19
9.0	Power Sequence	20
10.0	Mechanical Characteristics	21
11.0	Mechanical Drawing	22
12.0	Reliability Test	25
13.0	Handling & Cautions	25
14.0	Labels	27
15.0	Packing Information	29
16.0	EDID Table	30

1.0 GENERAL DESCRIPTION

1.1 Introduction

HX121WX1-101 is a color active matrix TFT LCD module using amorphous silicon TFT's (Thin Film Transistors) as an active switching devices. This module has a 12.1 inch diagonally measured active area with WXGA resolutions (1280 horizontal by 800 vertical pixel array). Each pixel is divided into RED, GREEN, BLUE dots which are arranged in vertical Stripe and this module can display 262,144 colors. The TFT-LCD panel used for this module is a low reflection and higher color type.

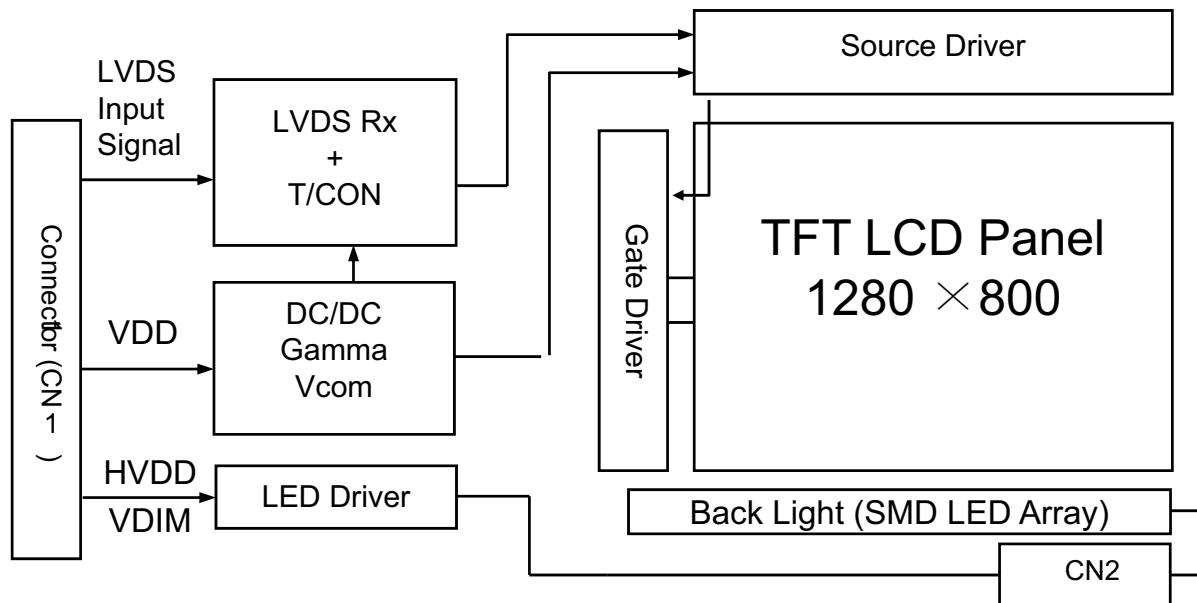

1.2 Features

- Thin and Light Weight
- 3.3 V Logic Power Supply
- 12V Back-light Power Supply
- 1 Channel LVDS Interface
- SMD LED (48EA) Array (Bottom Side/Horizontal Direction)
- 262,144 Colors
- Data Enable Signal Mode
- Side Mounting Frame
- Green Product (RoHS)
- Anti-Glare polarizer product

1.3 Application

- Tablet PC (Wide type)

1.4 General Specifications

Parameter	Specification	Unit	Remarks
Active area	261.12(H) × 163.20(V)	mm	
Number of pixels	1280(H) × 800(V)	pixels	
Pixel pitch	0.204(H) × 0.204(V)	mm	
Pixel arrangement	RGB Vertical Stripe		
Display colors	262,144	colors	
Display mode	Normally Black		
Outline dimension	276.8±0.3(H) × 180.0±0.3(V) × 6.8(D:Max.)	mm	Note 1
Weight	265(Typ.) / 275(Max.)	g	Note 2
Back-light	SMD LED (48EA) Array		
Surface treatment	Anti-Glare, 2H		

Note 1 : At PCB side (LED Side: 4.6mm Max.)

Note 2 : Without digitizer

2.0 ABSOLUTE MAXIMUM RATINGS

The followings are maximum values which, if exceed, may cause faulty operation or damage to the unit.

$T_a=25+/-2^{\circ}\text{C}$

Parameter	Symbol	Min.	Max.	Unit	Remarks
Logic Power Supply Voltage	V_{DD}	-0.3	4.0	V	
Logic Power Supply Voltage	V_{IN}	-0.3	$V_{DD}+0.3$	V	
Back-light Power Supply Voltage	HV_{DD}	-0.3	40	V	
Back-light LED Current	I_{LED}	-	30	mA	Note 1
Back-light LED Reverse Voltage	V_R	-	5	V	
Operating Temperature	T_{OP}	0	+50	$^{\circ}\text{C}$	Note 1, Note 2
Storage Temperature	T_{SP}	-20	+60	$^{\circ}\text{C}$	

Note 1. Ambient temperature vs allowable forward current are shown in the figure below.

Note 2. Temperature and relative humidity range are shown in the figure below.

90% RH Max. ($40^{\circ}\text{C} \geq T_a$)

Maximum wet - bulb temperature at 39°C or less. ($> 40^{\circ}\text{C}$) No condensation.

Ambient Temperature vs. Maximum Forward Current

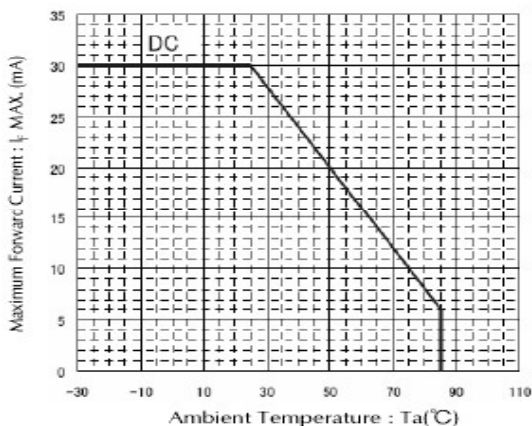

Relative Humidity

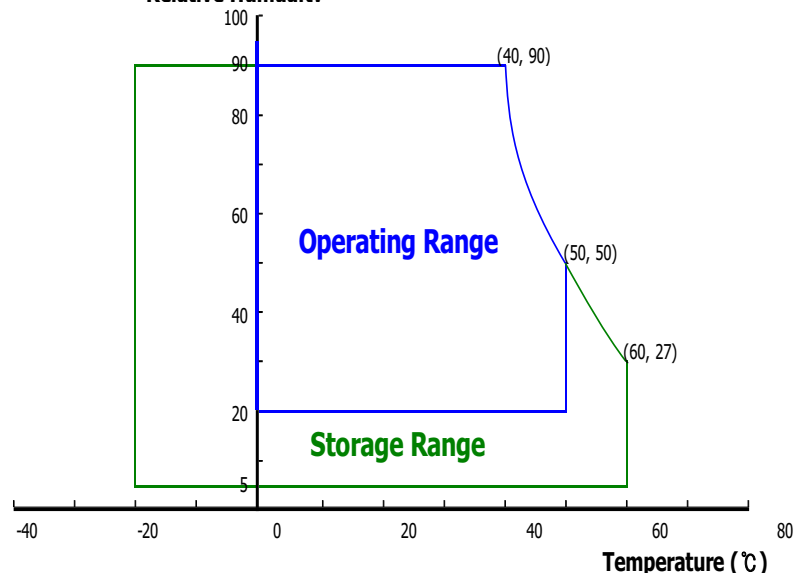

3.0 ELECTRICAL SPECIFICATIONS

3.1 Electrical Specifications

< Table 3. Electrical Specifications >

Parameter		Min.	Typ.	Max.	Unit	Remarks
Logic Power Supply Voltage	V_{DD}	3.0	3.3	3.6	V	Note 1
Logic Power Supply Current	I_{DD}	-	300	470	mA	Note 1
Back-light Power Supply Voltage	HV_{DD}	7.0	12.0	20	V	Note 2
Back-light Power Supply Current	I_{HVDD}	-	255	305	mA	Note 2, 3
Back-light Power Consumption	P_{BL}	-	3.06	3.66	W	Note 2, 3
LED Driver's Efficiency	η	-	82	-	%	Note 2, 3
Back-light PWM Frequency	F_{PWM}	200	320	350	Hz	
High Level PWM Signal Voltage	V_{PWMH}	2.1	3.3	5.0	V	
Low Level PWM Signal Voltage	V_{PWML}	-	0	0.6	V	
High Level Differential Input Signal Voltage	V_{IH}	-	-	+100	mV	$V_{CM} = 1.2V$
Low Level Differential Input Signal Voltage	V_{IL}	-100	-	-	mV	
Back-light LED Voltage / Back-light LED Total Voltage	V_{LED} / V_{BL}	-	3.2 / 38.4	3.5 / 42.0	V	Note 4
Back-light LED Current / Back-light LED Total Current	I_{LED} / I_{BL}	-	16.9 / 67.6	17.8 / 71.2	mA	Note 4
Life Time		10,000	-	-	Hrs	Note 6
EBL (Extended Battery Life)	P_D		0.95	1.50		Note 1, 2, 3
	P_{LED}		0.50	0.88		
	P_{total}		1.45	2.38		
Power Consumption	P_D	-	1.0	1.55	W	Note 1
	P_{LED}	-	2.60	2.99	W	Note 4
	P_{total}	-	3.60	4.54	W	Note 1, 4

- Notes :
1. The supply voltage is measured and specified at the interface connector of LCM.
The current draw and power consumption specified is for 3.3V at 25°C.
a) Typ : Window XP pattern, b) Max : Vertical Sub line pattern
c) EBL : Mosaic pattern (32 X 32)
 2. The power supply voltage and current is measured and specified at the interface connector of LCM including LED Driver.
 3. Reference value, which is measured with LED Driver for 12V.
 4. Reference value, which is measured without LED Driver.
 5. Calculated value for reference ($V_{LED} \times I_{LED} \times \# \text{ of LEDs (48EA) }$).
 6. End of Life shall be determined by the time when any of the following is satisfied under continuous lighting at 25°C and $I_{LED} = 16.9\text{mA}$.
 - . Intensity drops to 50% of the Initial Value (Luminance Spec.)
 - . Based on LED

3.2 PWM Duty Ratio vs Brightness

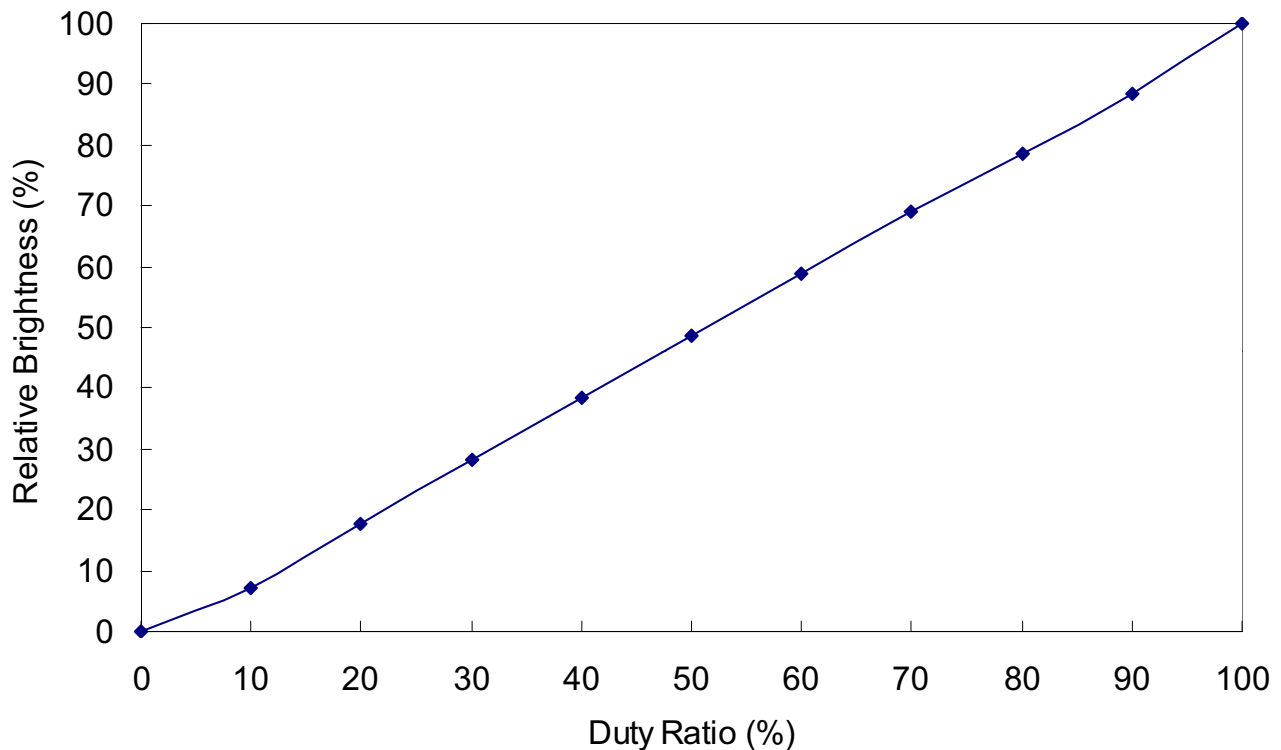

4.0 OPTICAL SPECIFICATIONS

4.1 Overview

The test of optical specifications shall be measured in a dark room (ambient luminance ≤ 1 lux and temperature = $25 \pm 2^\circ\text{C}$) with the equipment of Luminance meter system (Goniometer system and TOPCON BM-5A) and test unit shall be located at an approximate distance 50cm from the LCD surface at a viewing angle of θ and Φ equal to 0° . We refer to $\theta_{\Phi=0}$ ($=\theta_3$) as the 3 o'clock direction (the "right"), $\theta_{\Phi=90}$ ($=\theta_{12}$) as the 12 o'clock direction ("upward"), $\theta_{\Phi=180}$ ($=\theta_9$) as the 9 o'clock direction ("left") and $\theta_{\Phi=270}$ ($=\theta_6$) as the 6 o'clock direction ("bottom"). While scanning θ and/or Φ , the center of the measuring spot on the Display surface shall stay fixed. The backlight should be operating for 30 minutes prior to measurement. V_{DD} shall be $3.3 \pm 0.3\text{V}$ at 25°C . Optimum viewing angle direction is 6 o'clock.

4.2 Optical Specifications

<Table 4. Optical Specifications>

Parameter		Symbol	Condition	Min.	Typ.	Max.	Unit	Remarks
Viewing Angle Range	Horizontal	Θ_3	CR > 10	-	90	-	Deg.	Note 1
		Θ_9		-	90	-	Deg.	
	Vertical	Θ_{12}		-	90	-	Deg.	
		Θ_6		-	90	-	Deg.	
Luminance Contrast Ratio		CR		500	700	-		Note 2
Luminance of White	5 Points	Y_w		250	300	-	cd/m ²	
White Luminance Uniformity	5 Points	ΔY_5		80	-	-	%	Note 3
	13 Points	ΔY_{13}		60	-	-		
Color Chromaticity	White	W_x	$\Theta = 0^\circ$	0.273	0.313	0.353		Note 4
		W_y		0.289	0.329	0.369		
	Red	R_x		0.545	0.585	0.625		
		R_y		0.333	0.373	0.413		
	Green	G_x		0.305	0.345	0.385		
		G_y		0.525	0.565	0.605		
	Blue	B_x		0.110	0.150	0.190		
		B_y		0.098	0.138	0.178		
Color Reproduction					42		%	
Response Time	Total ($T_r + T_d$)		Ta= 25°C $\Theta = 0^\circ$	-	30	-	ms	Note 5
Cross Talk	CT		$\Theta = 0^\circ$	-	-	2.0	%	Note 6



Note : 1. Viewing angle is the angle at which the contrast ratio is greater than 10. The viewing are determined for the horizontal or 3, 9 o'clock direction and the vertical or 6, 12 o'clock direction with respect to the optical axis which is normal to the LCD surface (see FIGURE 1 shown in page 11).

2. Contrast measurements shall be made at viewing angle of $\Theta = 0^\circ$ and at the center of the LCD surface. Luminance shall be measured with all pixels in the view field set first to white, then to the dark (black) state. (See FIGURE 1 shown in page 11)
Luminance Contrast Ratio (CR) is defined mathematically.

$$CR = \frac{\text{Luminance when displaying a white raster}}{\text{Luminance when displaying a black raster}}$$

3. The White luminance uniformity on LCD surface is then expressed.
(See FIGURE 2~3 shown in page 12)

$$\text{Uniformity } \Delta Y = \frac{\text{Minimum Luminance of 5(or 13) points}}{\text{Maximum Luminance of 5(or 13) points}} \times 100 (\%)$$

4. The color chromaticity coordinates specified in Table 4 shall be calculated from the spectral data measured with all pixels first in red, green, blue and white. Measurements shall be made at the center of the panel.
5. The electro-optical response time measurements shall be made as FIGURE 4 shown in page 13 by switching the "data" input signal OFF and ON. The times needed for the luminance to change from 10% to 90% is T_r , and 90% to 10% is T_d . (See FIGURE 4 shown in page 13)
6. Cross-Talk of one area of the LCD surface by another shall be measured by comparing the luminance (YA) of a 25mm diameter area, with all display pixels set to a gray level, to the luminance (YB) of that same area when any adjacent area is driven dark. (See FIGURE 5 shown in page 13)

4.3 Optical Measurements

Figure 1. Measurement Set Up

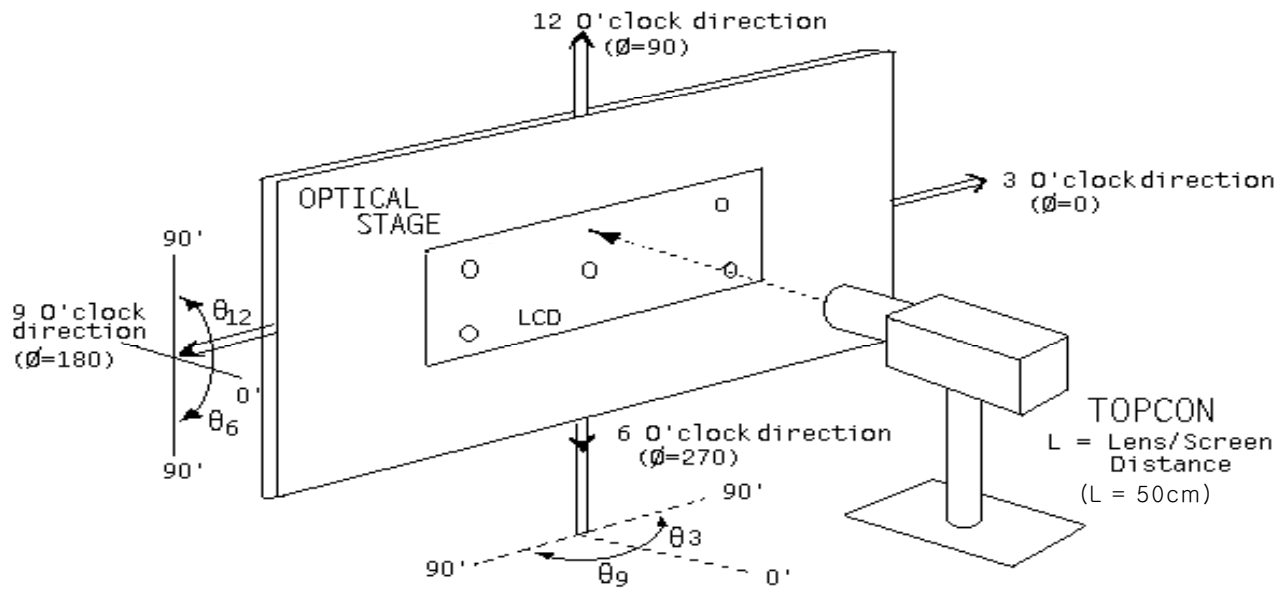

<Indoor>

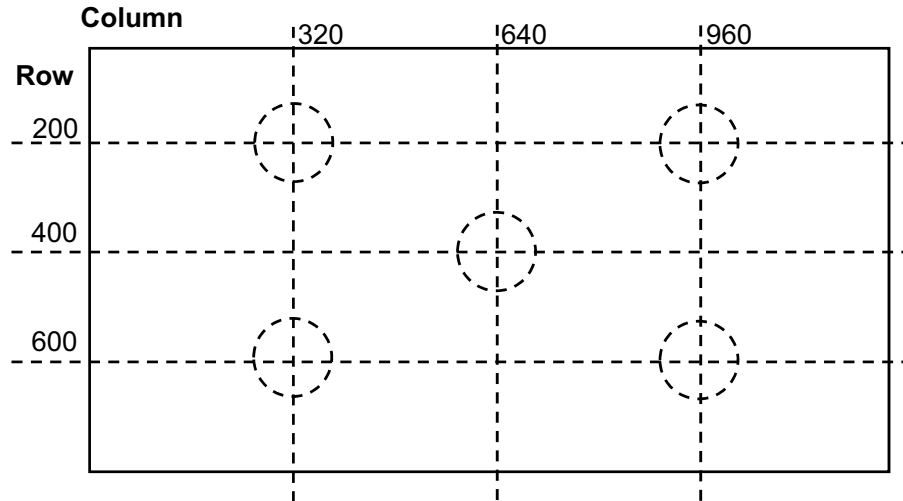
Figure 2. White Luminance and Uniformity Measurement Locations (5 points)

Note.

Luminance of white is defined as luminance values of 5 points across the LCD surface. Luminance shall be measured with all pixels in the view field set first to white. This measurement shall be taken at the locations shown in Figure 2 for a total of the measurements per display.

$$* Y_w = (\text{Sum of 5 Points Luminance} / 5)$$

Figure 3. Uniformity Measurement Locations (13 points)

Figure 4. Response Time Testing

Figure 5. Cross Modulation Test Description

$$\text{Cross-Talk (\%)} = \left| \frac{Y_B - Y_A}{Y_B} \right| \times 100$$

Where:

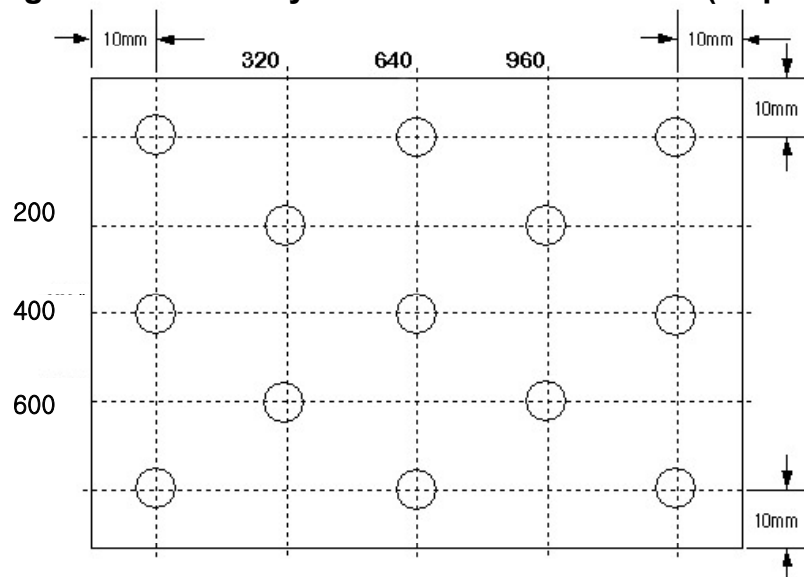
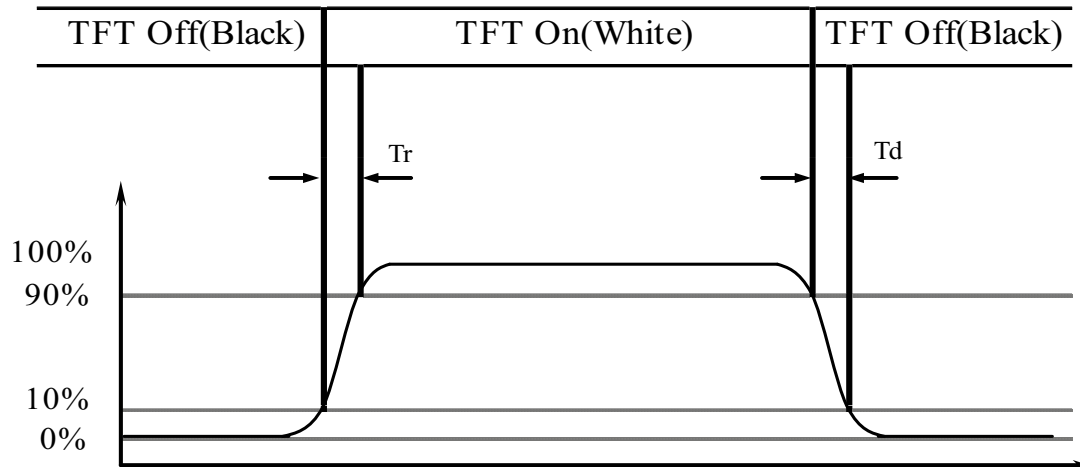
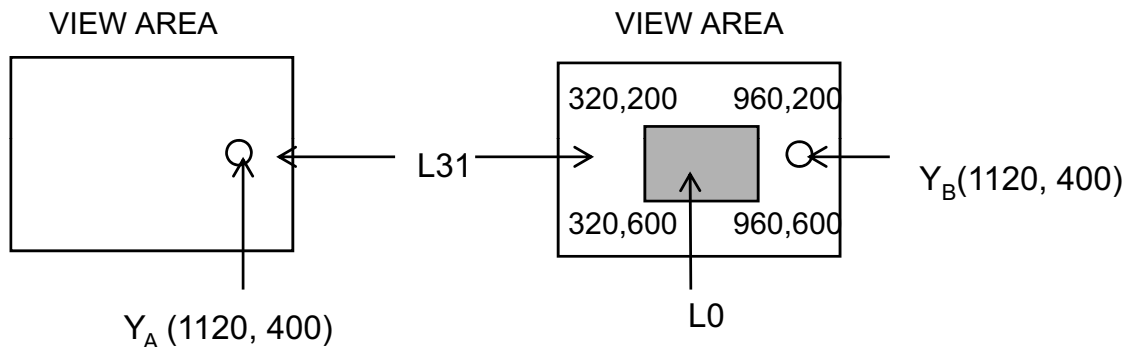
 Y_A = Initial luminance of measured area (cd/m²)

 Y_B = Subsequent luminance of measured area (cd/m²)

The location measured will be exactly the same in both patterns

5.0 INTERFACE CONNECTIONS

5.1 Electrical Interface Connection

CN1 Interface Connector (FI-JT40S-HF10, Manufactured by JAE)

Pin No.	Symbol	Function	Pin No.	Symbol	Function
1	GND1	GROUND	21	GND6	GROUND
2	CONNTST	Connector Test	22	RCLKIN-	LVDS Negative clock signal (-)
3	LVDD1	Logic Power Supply : +3.3V	23	RCLKIN+	LVDS Positive clock signal (+)
4	LVDD2	Logic Power Supply : +3.3V	24	GND7	GROUND
5	LVDD3	Logic Power Supply : +3.3V	25	VDIM	PWM Brightness Control
6	VDD_DEID	EDID Power Supply : +3.3V	26	Reserved	NON-CONNECTION
7	TEST	NON-CONNECTION	27	Reserved	NON-CONNECTION
8	CLK_EDID	EDID Clock	28	HVGND1	GROUND
9	DATA_EDID	EDID Data	29	HVGND2	GROUND
10	GND2	GROUND	30	HVGND3	GROUND
11	GND3	GROUND	31	HVGND4	GROUND
12	NC	NON-CONNECTION	32	HVGND5	GROUND
13	RIN0-	LVDS Negative data signal (-)	33	NC	NON-CONNECTION
14	RIN0+	LVDS Positive data signal (+)	34	HVDD1	Back-light Power Supply: +12V
15	GND4	GROUND	35	HVDD2	Back-light Power Supply: +12V
16	RIN1-	LVDS Negative data signal (-)	36	HVDD3	Back-light Power Supply: +12V
17	RIN1+	LVDS Positive data signal (+)	37	HVDD4	Back-light Power Supply: +12V
18	GND5	GROUND	38	HVDD5	Back-light Power Supply: +12V
19	RIN2-	LVDS Negative data signal (-)	39	CONNTST	Connector Test
20	RIN2+	LVDS Positive data signal (+)	40	GND8	GROUND

Note 1. Connected with No. 2 & 39

Note 2. Start from left side

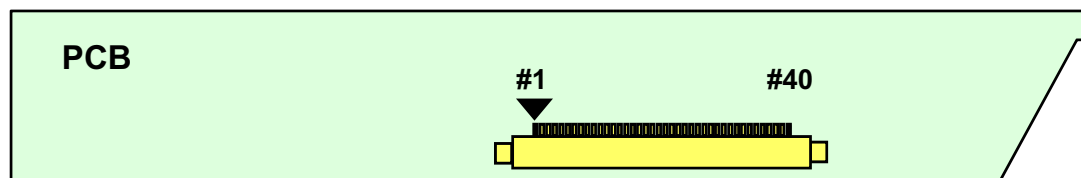

CN1 (FI-JH40S-HF10)

5.2 LVDS Interface
LVDS Transmitter : THC63LVDM83A

Input signal	Transmitter		Interface		FI-JH40S-HF10	Remark
	Pin No	Pin No	System (Tx)	TFT-LCD (Rx)	Pin No.	
R0	51	48 47	OUT0- OUT0+	IN0- IN0+	13 14	
R1	52					
R2	54					
R3	55					
R4	56					
R5	3					
G0	4	46 45	OUT1- OUT1+	IN1- IN1+	16 17	
G1	6					
G2	7					
G3	11					
G4	12					
G5	14					
B0	15	42 41	OUT2- OUT2+	IN2- IN2+	19 20	
B1	19					
B2	20					
B3	22					
B4	23					
B5	24					
HSYNC	27	40	CLKOUT-	CLKIN-	22	
VSYNC	28					
DE	30	39	CLKOUT+	CLKIN+	23	
MCLK	31					

5.3 Back-light Interface

CN2 LED FPC Connector (04-6298-009, Manufactured by Kyocera)

Pin No.	Symbol	Function	Remark
1	Anode1	LED Anode Power Supply	LED Anode Power Supply (3.25V X 12EA = 39V)
2	Anode2	LED Anode Power Supply	
3	Anode3	LED Anode Power Supply	
4	Anode4	LED Anode Power Supply	
5	NC	Non-Connection	
6	Cathode1	LED Cathode Power Supply	LED Cathode Power Supply
7	Cathode2	LED Cathode Power Supply	
8	Cathode3	LED Cathode Power Supply	
9	Cathode4	LED Cathode Power Supply	

5.4 Data Input Format

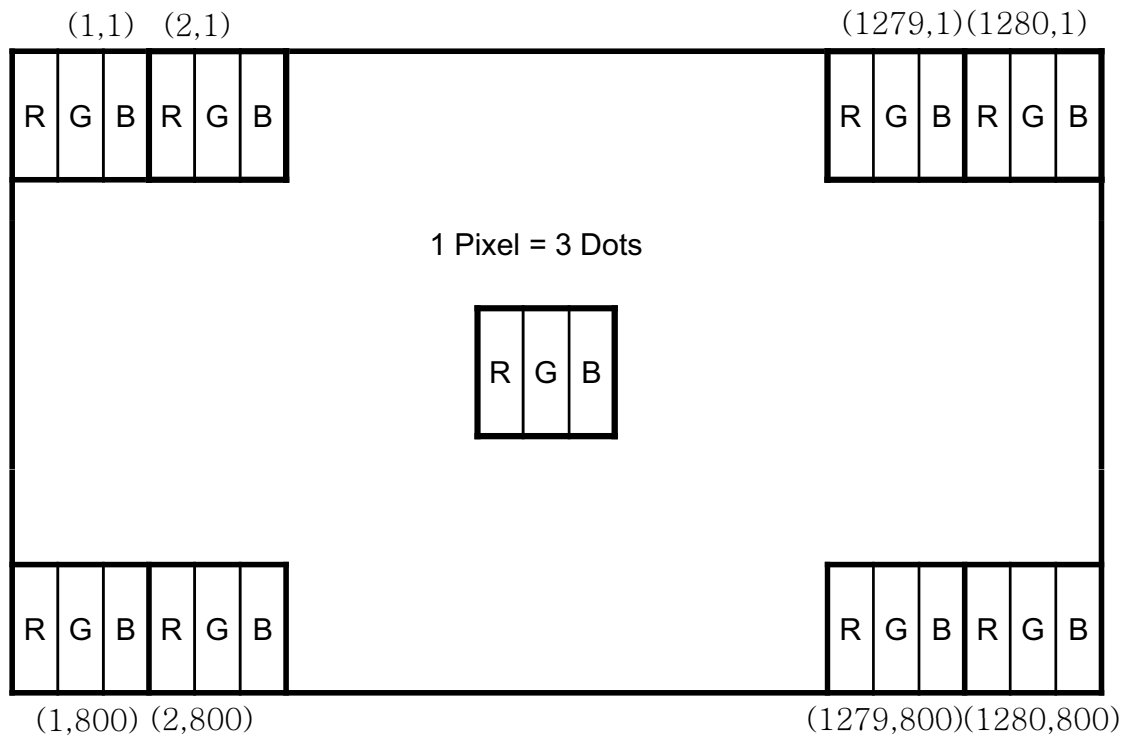

6.0. SIGNAL TIMING SPECIFICATIONS

6.1 The 12.1" WXGA LCM is operated by the only DE (Data enable) mode (LVDS Transmitter Input)

Item	Symbol	Min.	Typ.	Max.	Unit
Frame Period	T1	810	823	-	Lines
Vertical Display Period	T2	-	800	-	Lines
One line Scanning Period	T3	1350	1440	-	Clocks
Horizontal Display Period	T4	-	1280	-	Clocks
Clock Frequency	1/T5	-	71.11	-	MHz

7.0 SIGNAL TIMING WAVEFORMS

7.1 Timing Waveforms of Interface Signal

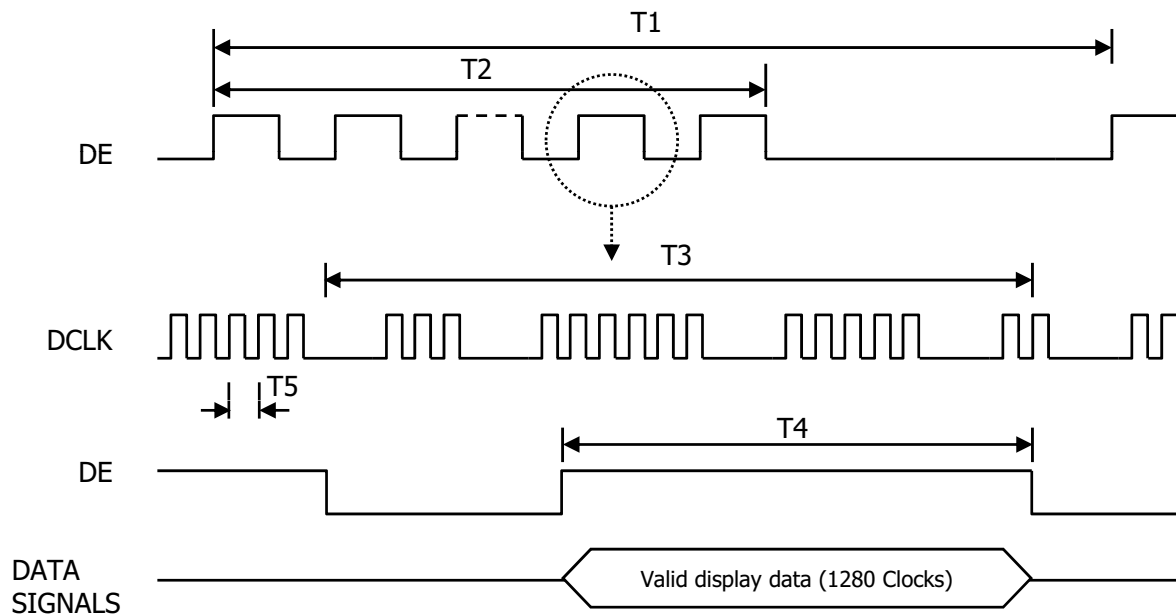

7.2 LVDS Rx Interface Timing Parameter

The specification of the LVDS Rx interface timing parameter

< LVDS Rx Interface Timing Specification >

Item	Symbol	Min.	Typ.	Max.	Unit	Remarks
CLKIN Period	tRCIP	12.50	14.06	25.00	nsec	
Input Data 0	tRIP0	-0.4	0.0	+0.4	nsec	
Input Data 1	tRIP1	tRCIP/7-0.4	tRCIP/7	tRCIP/7+0.4	nsec	
Input Data 2	tRIP2	2 × tRCIP/7-0.4	2 × tRCIP/7	2 × tRCIP/7+0.4	nsec	
Input Data 3	tRIP3	3 × tRCIP/7-0.4	3 × tRCIP/7	3 × tRCIP/7+0.4	nsec	
Input Data 4	tRIP4	4 × tRCIP/7-0.4	4 × tRCIP/7	4 × tRCIP/7+0.4	nsec	
Input Data 5	tRIP5	5 × tRCIP/7-0.4	5 × tRCIP/7	5 × tRCIP/7+0.4	nsec	
Input Data 6	tRIP6	6 × tRCIP/7-0.4	6 × tRCIP/7	6 × tRCIP/7+0.4	nsec	

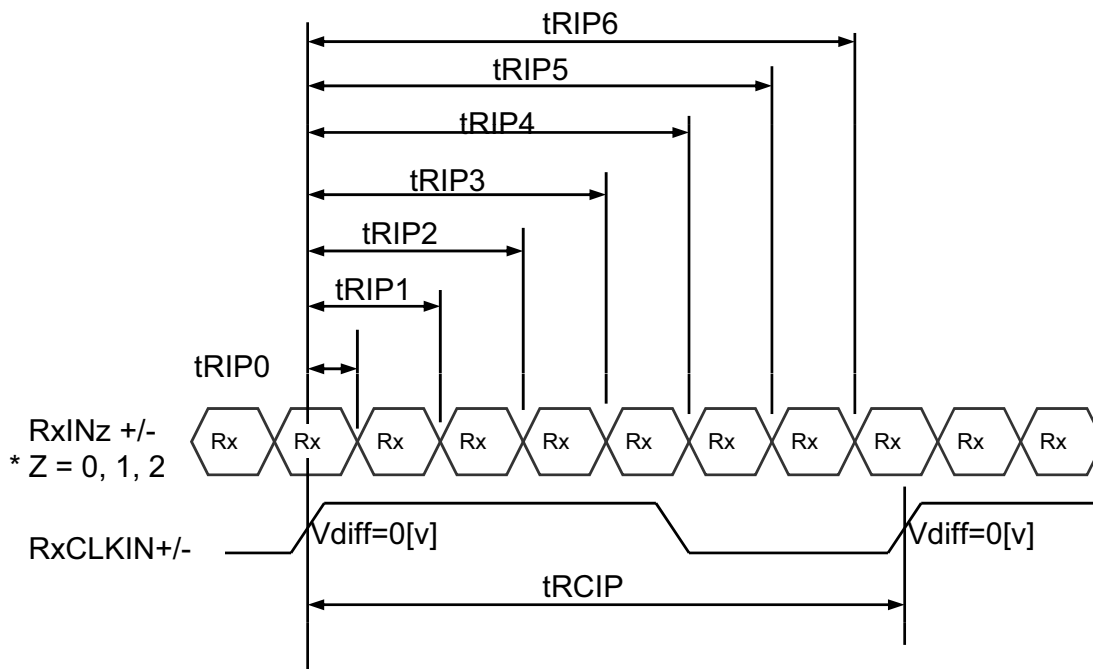

8.0 INPUT SIGNALS, BASIC DISPLAY COLORS & GRAY SCALE OF COLORS

Each color is displayed in sixty-four gray scales from a 6 bit data signal input. A total of 262,144 colors are derived from the resultant 18 bit data.

Colors & Gray Scale		Red Data						Green Data						Blue Data					
		R5	R4	R3	R2	R1	R0	G5	G4	G3	G2	G1	G0	B5	B4	B3	B2	B1	B0
Basic Colors	Black	0	0	0	0	0	0	0	0	0	0	0	0	0	0	0	0	0	0
	Blue	0	0	0	0	0	0	0	0	0	0	0	0	1	1	1	1	1	1
	Green	0	0	0	0	0	0	1	1	1	1	1	1	0	0	0	0	0	0
	Cyan	0	0	0	0	0	0	1	1	1	1	1	1	1	1	1	1	1	1
	Red	1	1	1	1	1	1	0	0	0	0	0	0	0	0	0	0	0	0
	Magenta	1	1	1	1	1	1	0	0	0	0	0	0	1	1	1	1	1	1
	Yellow	1	1	1	1	1	1	1	1	1	1	1	1	0	0	0	0	0	0
	White	1	1	1	1	1	1	1	1	1	1	1	1	1	1	1	1	1	1
Gray Scale Of Red	Black	0	0	0	0	0	0	0	0	0	0	0	0	0	0	0	0	0	0
	△	0	0	0	0	0	1	0	0	0	0	0	0	0	0	0	0	0	0
	Darker	0	0	0	0	1	0	0	0	0	0	0	0	0	0	0	0	0	0
	△	↓						↓						↓					
	▽	↓						↓						↓					
	Brighter	1	1	1	1	0	1	0	0	0	0	0	0	0	0	0	0	0	0
	▽	1	1	1	1	1	0	0	0	0	0	0	0	0	0	0	0	0	0
	Red	1	1	1	1	1	1	0	0	0	0	0	0	0	0	0	0	0	0
Gray Scale Of Green	Black	0	0	0	0	0	0	0	0	0	0	0	0	0	0	0	0	0	0
	△	0	0	0	0	0	0	0	0	0	0	0	1	0	0	0	0	0	0
	Darker	0	0	0	0	0	0	0	0	0	0	1	0	0	0	0	0	0	0
	△	↓						↓						↓					
	▽	↓						↓						↓					
	Brighter	0	0	0	0	0	0	1	1	1	1	0	1	0	0	0	0	0	0
	▽	0	0	0	0	0	0	1	1	1	1	1	0	0	0	0	0	0	0
	Green	0	0	0	0	0	0	1	1	1	1	1	1	0	0	0	0	0	0
Gray Scale Of Blue	Black	0	0	0	0	0	0	0	0	0	0	0	0	0	0	0	0	0	0
	△	0	0	0	0	0	0	0	0	0	0	0	0	0	0	0	0	0	1
	Darker	0	0	0	0	0	0	0	0	0	0	0	0	0	0	0	0	1	0
	△	↓						↓						↓					
	▽	↓						↓						↓					
	Brighter	0	0	0	0	0	0	0	0	0	0	0	0	1	1	1	1	0	1
	▽	0	0	0	0	0	0	0	0	0	0	0	0	1	1	1	1	1	0
	Blue	0	0	0	0	0	0	0	0	0	0	0	0	1	1	1	1	1	1
Gray Scale Of White & Black	Black	0	0	0	0	0	0	0	0	0	0	0	0	0	0	0	0	0	0
	△	0	0	0	0	0	1	0	0	0	0	0	1	0	0	0	0	0	1
	Darker	0	0	0	0	1	0	0	0	0	0	1	0	0	0	0	0	1	0
	△	↓						↓						↓					
	▽	↓						↓						↓					
	Brighter	1	1	1	1	0	1	1	1	1	1	0	1	1	1	1	1	0	1
	▽	1	1	1	1	1	0	1	1	1	1	1	0	1	1	1	1	1	0
	White	1	1	1	1	1	1	1	1	1	1	1	1	1	1	1	1	1	1

9.0 POWER SEQUENCE

To prevent a latch-up or DC operation of the LCD module, the power on/off sequence shall be as shown in below

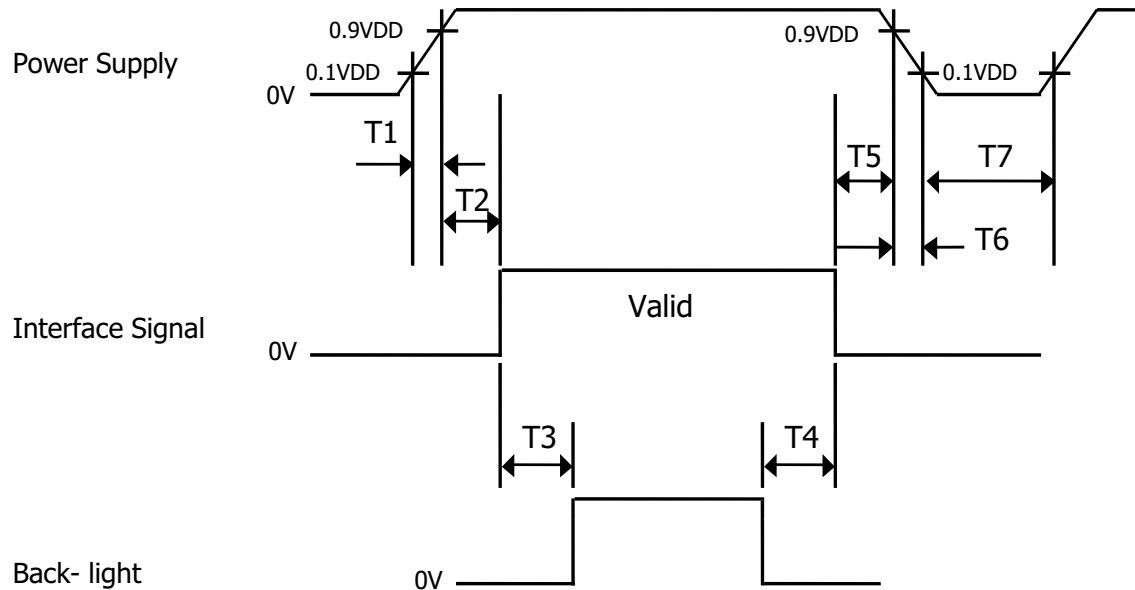

- $T1 \leq 10 \text{ ms}$
- $0 \leq T2 \leq 50 \text{ ms}$
- $200 \text{ ms} \leq T3$
- $200 \text{ ms} \leq T4$
- $0 \leq T5 \leq 50 \text{ ms}$
- $0 \leq T6 \leq 10 \text{ ms}$
- $500 \text{ ms} \leq T7$

- Notes :
1. When the power supply VDD is 0V, Keep the level of input signals on the low or keep high impedance.
 2. Do not keep the interface signal high impedance when power is on.
 3. Back Light must be turn on after power for logic and interface signal are valid.

10.0 MECHANICAL CHARACTERISTICS

10.1 Dimensional Requirements

Figure 6 & 7 (located in 11.0) shows mechanical outlines for the model

Parameter	Specification	Unit
Active Area	261.12(H) X 163.20(V)	mm
Number of pixels	1280(H) X 800(V) (1 pixel = R + G + B dots)	
Pixel pitch	0.204(H) X 0.204(V)	
Pixel arrangement	RGB Vertical stripe	
Display colors	262,144	
Display mode	Normally Black	
Outline dimension	276.8±0.3(H)×180.0(V)±0.3×6.8(D:Max.)	mm
Weight	265(Typ.) / 275(Max.)	g
Back-light	SMD LED (48EA) Array	

10.2 Mounting

See Figure 6 & 7 & 8. (shown in 11.0)

Parameter	Specification	Unit
Torque of side mounting screw	2.5(Max.)	kgf
Torque of ground plate screw	1.5(Max.)	kgf
Torque of top side screw	2.5(Max.)	kgf

10.3 Anti-Glare and Polarizer Hardness.

The surface of the LCD has an anti-glare coating to minimize reflection and a coating to reduce scratching.

10.4 Light Leakage

There shall not be visible light from the back-lighting system around the edges of the screen as seen from a distance 50cm from the screen with an overhead light level of 150lux. The manufacture shall furnish limit samples of the panel showing the light leakage acceptable.

11.0 Mechanical Drawing

Figure 6. TFT-LCD Module Outline Dimension (Front View)

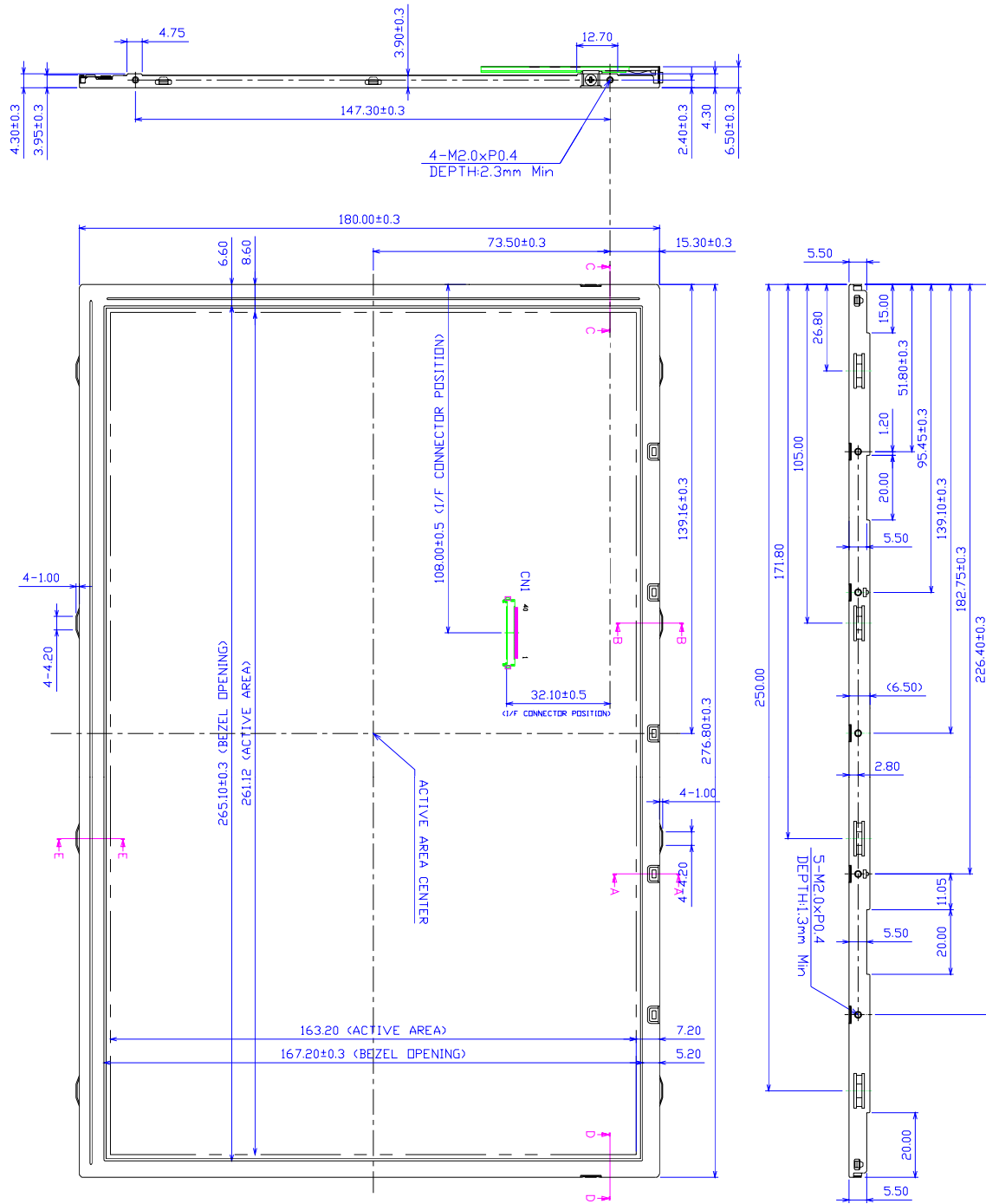

SPEC. NUMBER
S864-1366

SPEC TITLE
HX121WX1-101 Product Specification for Customer

PAGE
22 OF 33

Figure 7. TFT-LCD Module Outline Dimensions (Rear view)

Figure 8. TFT-LCD Module Section for Mounting

SECTION A-A(S:5/1)

SECTION B-B(S:5/1)

SECTION C-C(S:5/1)

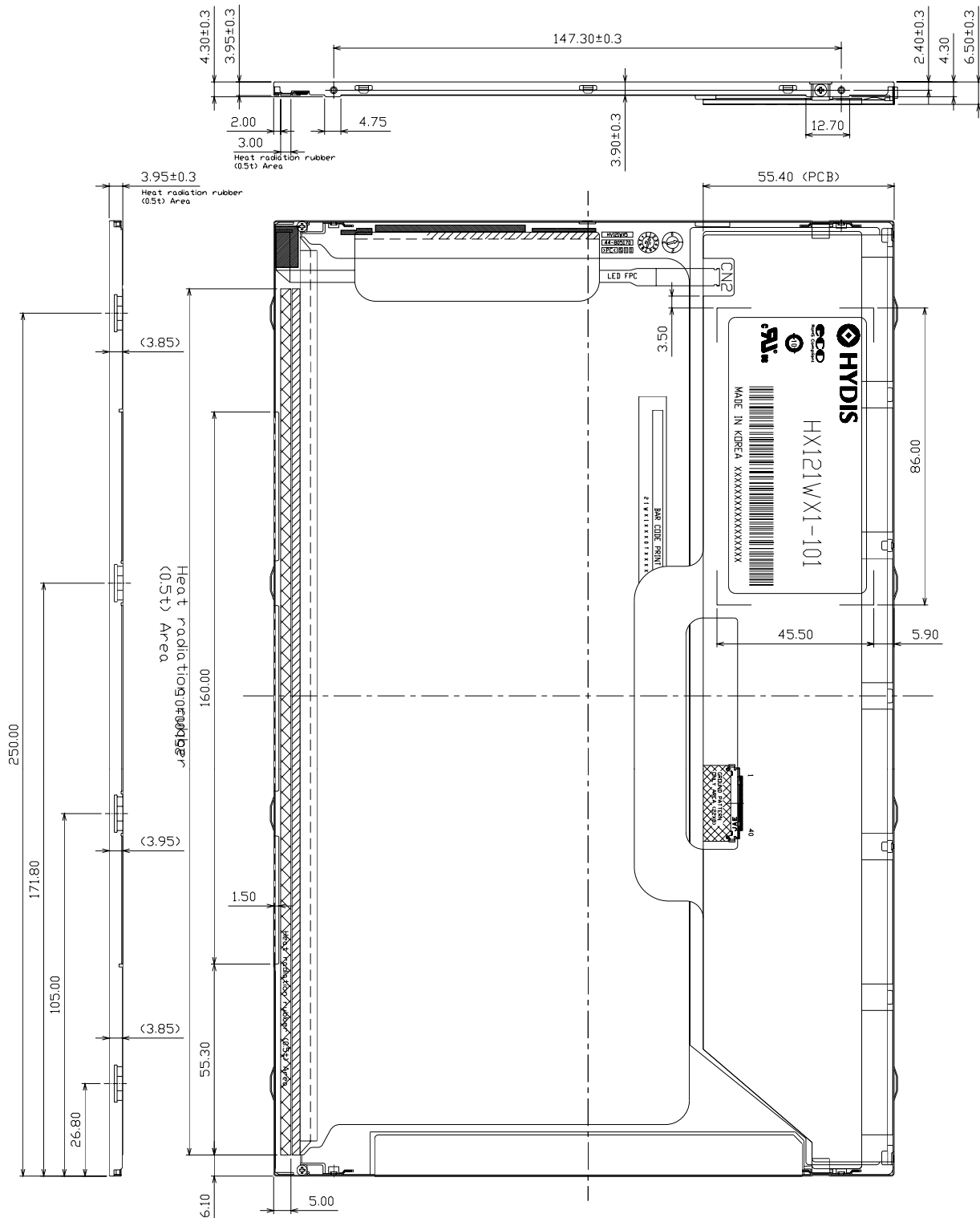
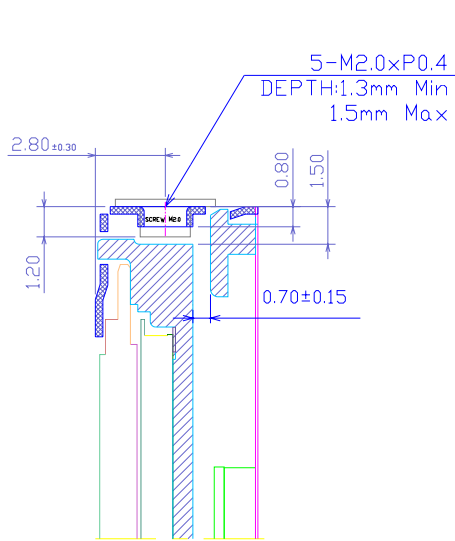
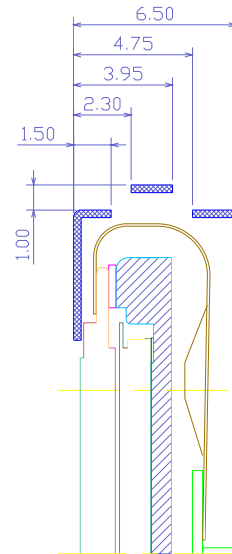
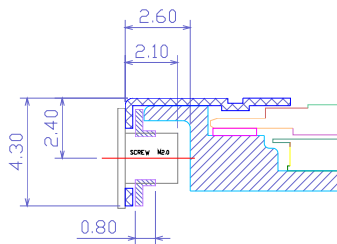
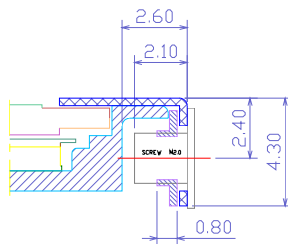
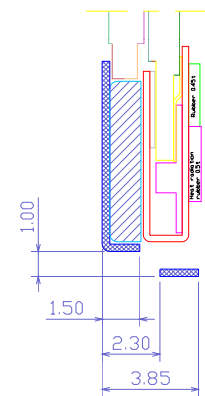
SECTION D-D(S:5/1)

SECTION E-E(S:5/1)

12.0 RELIABILITY TEST

The Reliability test items and its conditions are shown in below.

<Table 12. Reliability Test>

No	Test Item	Conditions
1	High temperature storage test	Ta = 60 °C, 240 hrs
2	Low temperature storage test	Ta = -20 °C, 240 hrs
3	High temperature & high humidity operation test	Ta = 50 °C, 80%RH, 240hrs
4	High temperature operation test	Ta = 50 °C, 240 hrs
5	Low temperature operation test	Ta = 0 °C, 240 hrs
6	Thermal shock	Ta = -20 °C ↔ 60 °C (30 min), 100 cycle
7	Vibration test (non-operating)	Frequency : 10~500Hz Gravity/AMP : 1.5G Period : X,Y,Z 30min
8	Shock test (non-operating)	Gravity : 220G Pulse width : 2ms, half sine wave ±X, ±Y, ±Z Once for each direction
9	Electro-static discharge test (non-operating)	Air : 150pF, 330ohm, 15KV Contact : 150pF, 330ohm, 8KV

13.0 HANDLING & CAUTIONS

13.1 Cautions when taking out the module

- Pick the pouch only, when taking out module from a shipping package.

13.2 Cautions for handling the module

- As the electrostatic discharges may break the LCD module, handle the LCD module with care. Peel a protection sheet off from the LCD panel surface as slowly as possible.
- As the LCD panel and back - light element are made from fragile glass (epoxy) material, impulse and pressure to the LCD module should be avoided.
- As the surface of the polarizer is very soft and easily scratched, use a soft dry cloth without chemicals for cleaning.
- Do not pull the interface connector in or out while the LCD module is operating.
- Put the module display side down on a flat horizontal plane.
- Handle connectors and cables with care.

13.3 Cautions for the operation

- When the module is operating, do not lose MCLK, DE signals. If any one of these signals were lost, the LCD panel would be damaged.
- Obey the supply voltage sequence. If wrong sequence is applied, the module would be damaged.

13.4 Cautions for the atmosphere

- Dew drop atmosphere should be avoided.
- Do not store and/or operate the LCD module in a high temperature and/or humidity atmosphere. Storage in an electro-conductive polymer packing pouch and under relatively low temperature atmosphere is recommended.

13.5 Cautions for the module characteristics

- Do not apply fixed pattern data signal to the LCD module at product aging.
- Applying fixed pattern for a long time may cause image sticking.

13.6 Cautions for the digitizer assembly

- When assembling FPC connector, do not flip connector past 90° due to possible damage to connector.
- When positioning digitizer underneath driver IC, do not lift driver IC past 90° due to possible damage to driver IC pattern.
- Please be warned that during assembly of digitizer, the opening or closing of FPC will result in possible electrostatic discharge damage to the LED

13.7 Other cautions

- Do not re-adjust variable resistor or switch etc.
- When returning the module for repair or etc., Please pack the module not to be broken. We recommend to use the original shipping packages.

14.0 LABELS

14.1 Product Label

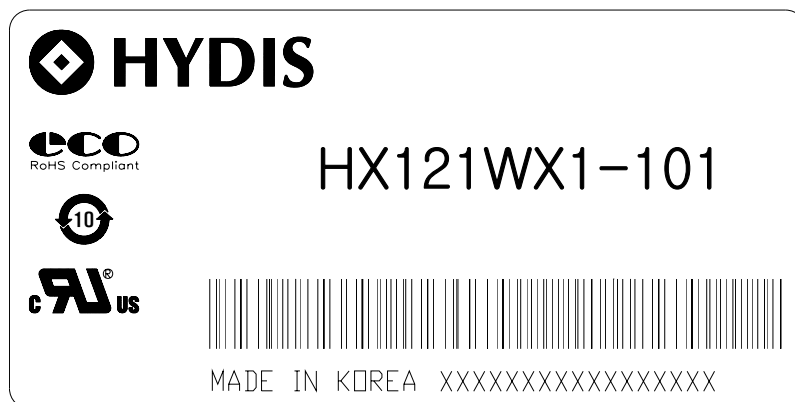

HYDIS Barcode

1	2	3	4	5	6	7
X X	X	X	X X	X	X X X X	X X X X X X

No 1. Control Number

No 5. Month (1, 2, 3, ..., 9, X, Y, Z)

No 2. Rank / Grade

No 6. FG Code

 No 3. Line Classification
(HYDIS : H)

No 7. Serial Number

No 4. Year (5 : 2005, 6 : 2006, ...)

14.2 Packing Label

Label Size: 108 mm (L) × 56 mm (W)

Contents

Model: HX121WX1-101

Q`ty: Module Q`ty in one box

Serial No.: Box Serial No. See next figure for detail description.

Date: Packing Date

FG Code: FG Code of Product

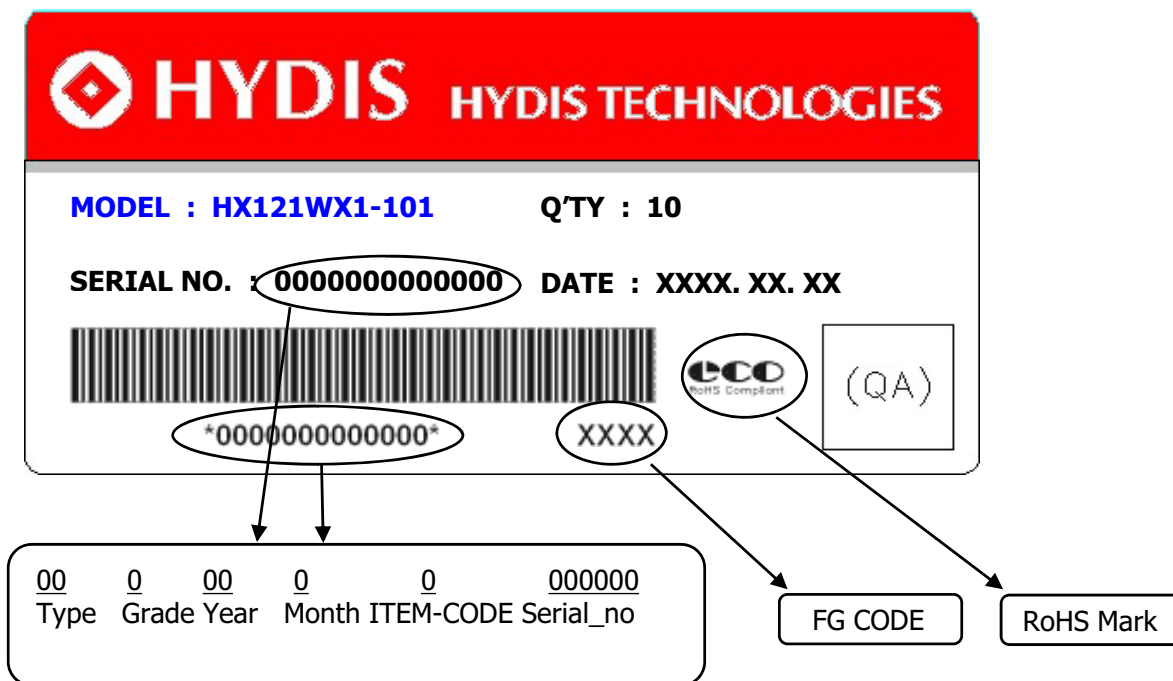

15.0 PACKING INFORMATION

15.1 Packing order

Put Pad into the box.

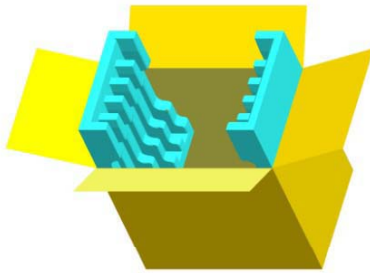

Put silica gels in the box.

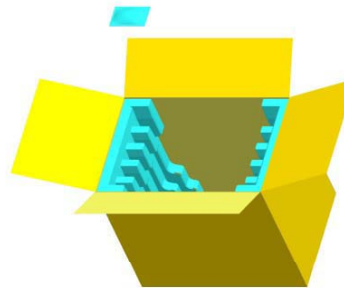

After sealing the box, attach Packing Label on the attach position sign area of the box.

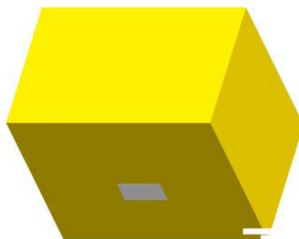

Place a cover on the top of the box.

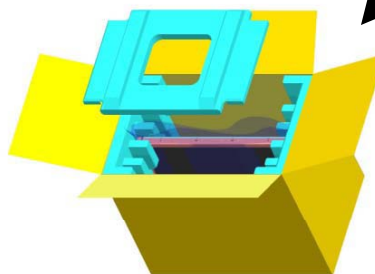

As shown in the figure, place the Modules bundled by shielding bag in the box.

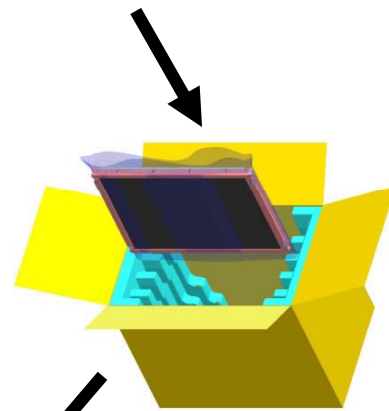

15.2 Notes

- Box Dimension : 349.0mm(W) X 261.0mm(D) X 311.0mm(H)
- Package Quantity in one Box : 10pcs

16.0 EDID Table

EDID chip is 24LC024 (Microchip) or equivalent .

Address (HEX)	Function	Hex	Dec	values.	Notes
00	Header	00	0		EDID Header
01		FF	255		
02		FF	255		
03		FF	255		
04		FF	255		
05		FF	255		
06		FF	255		
07		00	0		
08	ID Manufacturer Name	09	9		
09		E5	229		
0A	ID Product Code	9D	157	2205	CODE = 2205
0B		08	8		
0C	32-bit serial No.	00	0		
0D		00	0		
0E		00	0		
0F		00	0		
10	Week of manufacture	00	0		
11	Year of Manufacture	12	18	2008	Manufactured in 2008
12	EDID Structure Ver.	01	1	1	EDID Ver 1.0
13	EDID revision #	03	3	3	EDID Rev. 0.3
14	Video input definition	80	128		
15	Max H image size	1A	26	26	26 cm (Approx)
16	Max V image size	10	16	16	16 cm (Approx)
17	Display Gamma	78	120	2.2	Gamma curve = 2.2
18	Feature support	0A	10		RGB display, Preferred Timming mode
19	Red/Green low bits	E7	231		Red / Green Low Bits
1A	Blue/White low bits	95	149		Blue / White Low Bits
1B	Red x high bits	95	149	0.585	Rx
1C	Red y high bits	5F	95	0.373	Ry
1D	Green x high bits	58	88	0.345	Gx
1E	Green y high bits	90	144	0.565	Gy
1F	Blue x high bits	26	38	0.150	Bx
20	Blue y high bits	23	35	0.138	By
21	White x high bits	50	80	0.313	Wx
22	White y high bits	54	84	0.329	Wy

Address (HEX)	Function	Hex	Dec	values.	Notes
23	Established timing 1	00	0		
24	Established timing 2	00	0		
25	Established timing 3	00	0		
26	Standard timing #1	01	1		Not Used
27		01	1		
28	Standard timing #2	01	1		Not Used
29		01	1		
2A	Standard timing #3	01	1		Not Used
2B		01	1		
2C	Standard timing #4	01	1		Not Used
2D		01	1		
2E	Standard timing #5	01	1		Not Used
2F		01	1		
30	Standard timing #6	01	1		Not Used
31		01	1		
32	Standard timing #7	01	1		Not Used
33		01	1		
34	Standard timing #8	01	1		Not Used
35		01	1		
36	Detailed timing/monitor descriptor #1 (60Hz)	C7	199	71.11	71.11MHz Main clock
37		1B	27		
38		00	0	1280	Hor Active = 1280
39		A0	160	160	Hor Blanking = 160
3A		50	80		4 bits of Hor. Active + 4 bits of Hor. Blanking
3B		20	32	800	Ver Active = 800
3C		17	23	23	Ver Blanking = 23
3D		30	48		4 bits of Ver. Active + 4 bits of Ver. Blanking
3E		30	48	48	Hor Sync Offset = 48
3F		20	32	32	H Sync Pulse Width = 32
40		36	54	3	V sync Offset = 3 line
41		00	0	6	V Sync Pulse width : 6 line
42		05	5	261	Horizontal Image Size = 261 mm (Low 8 bits)
43		A3	163	163	Vertical Image Size = 163 mm (Low 8 bits)
44		10	16		4 bits of Hor Image Size + 4 bits of Ver Image Size
45		00	0		Hor Border (pixels)
46		00	0		Vertical Border (Lines)
47	19	25			

Address (HEX)	Function	Hex	Dec	values.	Notes
48	Detailed timing/monitor descriptor #2	00	0		
49		00	0		
4A		00	0		
4B		FE	254		
4C		00	0		
4D		0A	10		
4E		20	32		
4F		20	32		
50		20	32		
51		20	32		
52		20	32		
53		20	32		
54		20	32		
55		20	32		
56		20	32		
57		20	32		
58		20	32		
59		20	32		
5A	Detailed timing/monitor descriptor #3	00	0		
5B		00	0		
5C		00	0		
5D		FE	254		
5E		00	0		
5F		48	72	H	
60		59	89	Y	
61		44	68	D	
62		49	73	I	
63		53	83	S	
64		0A	10		
65		20	32		
66		20	32		
67		20	32		
68	20	32			
69	20	32			
6A	20	32			
6B	20	32			

Address (HEX)	Function	Hex	Dec	values.	Notes
6C	Detailed timing/monitor descriptor #4	00	0		Product Name Tag (ASCII)
6D		00	0		
6E		00	0		
6F		FE	254		
70		00	0		Model name : HX121WX1
71		48	72	H	
72		58	88	X	
73		31	49	1	
74		32	50	2	
75		31	49	1	
76		57	87	W	
77		58	88	X	
78		31	49	1	
79		0A	10		
7A		20	32		
7B		20	32		
7C	20	32			
7D	20	32			
7E	Extension flag	00	0		
7F	Checksum	BF			