

VI TELEFILTER**Filter Specification****TFS 211 A 1/4****Measurement condition**

Ambient temperature: 23 °C
 Input power level: 0 dBm
 Terminating Impedances:
 Source: 780 Ω || -5,9 pF
 Load: 580 Ω || -7,0 pF

Characteristics

Remark:

Reference level for the relative attenuation a_{rel} of the TFS 211 A is the minimum of the pass band attenuation a_{min} . The minimum of the pass band attenuation a_{min} is defined as the insertion loss a_e . The reference frequency f_c is the arithmetic mean value of the upper and lower frequencies at the 3 dB filter attenuation level relative to the insertion loss a_e . The peak to peak pass band ripple is the maximum attenuation level difference between adjacent local minima and local maxima of the pass band. This ripple is only measured if more than one local maxima or minima exist. The values below are guaranteed in the whole operating temperature range.

D a t a		typ. value	tolerance / limit
Insertion loss (reference level)	$a_e = a_{min}$	6 dB	8 dB
Reference frequency	f_c (3 dB-BW)	211 MHz	± 50 kHz
Peak to peak pass band ripple dB $f_c \pm 125$ kHz			max. 0.5
Relative attenuation	a_{rel}		
$f_c \pm 125$ kHz		-	≥ 1 dB
$f_c \pm 300$ kHz		-	≥ 3 dB
$f_c \pm 700$ kHz ... $f_c \pm 800$ kHz		-	≤ 20 dB
$f_c \pm 800$ kHz ... $f_c \pm 900$ kHz		-	≥ 30 dB
$f_c \pm 900$ kHz ... $f_c \pm 3$ MHz		-	≥ 40 dB
$f_c \pm 3$ MHz ... $f_c \pm 10$ MHz		-	≥ 50 dB
Group delay ripple $f_c \pm 300$ kHz			max. 600 ns
Triple transit echo attenuation			min. 30 dB
Temperature coefficient	TC 2nd order **)	- 0,035 ppm/K ²	-
Frequency inversion temperature	T_o	+ 10 °C	-
Operating temperature range		- 40 °C ... + 85 °C	
Storage temperature range		- 40 °C ... + 85 °C	
Input power level		-	max. + 10 dBm
Permissible DC voltage	V_{DC}	-	12 V

**) $\Delta f(\text{Hz}) = TC_f(\text{ppm/K}^2) \times (T - T_o)^2 \times f_{T_o}(\text{MHz})$

Generated: _____

Checked / approved: _____

VI TELEFILTER
 Potsdamer Straße 18
 D 14 513 TELTOW / Germany
 Tel: (+49) 3328 4784-52 / Fax: (+49) 3328 4784-30
 E-Mail: tft@telefilter.com

Vectron International, Inc.
 267 Lowell Road
 Hudson, NH 03051 / USA
 Tel: (603) 598-0070 Fax: (603) 598-0075
 E-Mail: vti@vtinh.com

VI TELEFILTER reserves the right to make changes to the product(s) and/or information contained herein without notice. No liability is assumed as a result of their use or application. No rights under any patent accompany the sale of any such product(s) or information.

VI TELEFILTER**Filter Specification****TFS 211 A 2/4****Construction, pin connection and 50 Ω test circuit**

(All dimensions in mm)

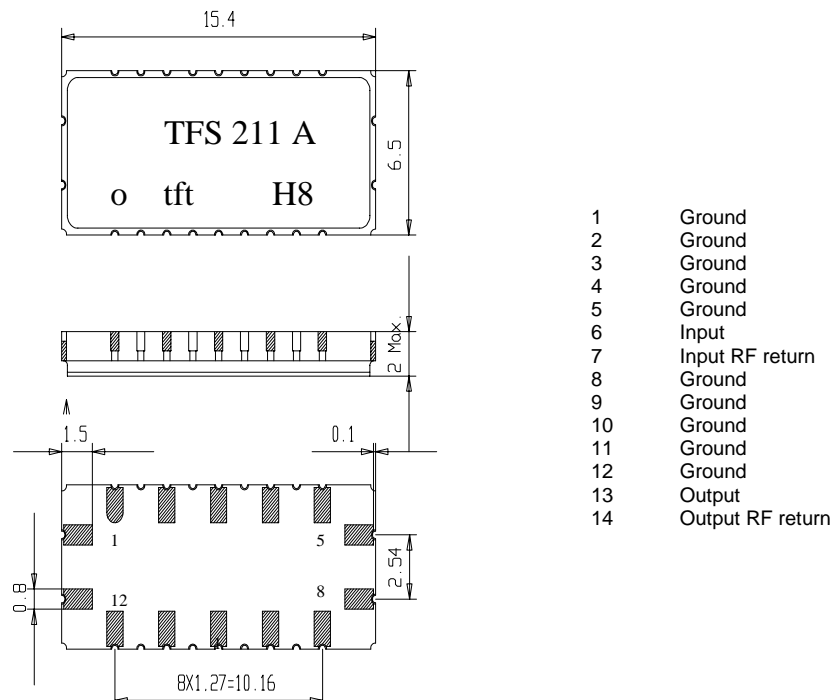

- | | |
|----|------------------|
| 1 | Ground |
| 2 | Ground |
| 3 | Ground |
| 4 | Ground |
| 5 | Ground |
| 6 | Input |
| 7 | Input RF return |
| 8 | Ground |
| 9 | Ground |
| 10 | Ground |
| 11 | Ground |
| 12 | Ground |
| 13 | Output |
| 14 | Output RF return |

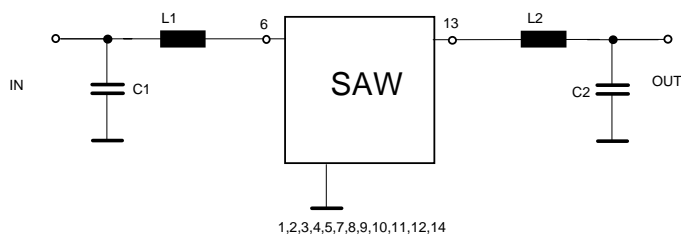
50 Ω test circuit

VI TELEFILTER
 Potsdamer Straße 18
 D 14 513 TELTOW / Germany
 Tel: (+49) 3328 4784-52 / Fax: (+49) 3328 4784-30
 E-Mail: tft@telefilter.com

Vectron International, Inc.
 267 Lowell Road
 Hudson, NH 03051 / USA
 Tel: (603) 598-0070 Fax: (603) 598-0075
 E-Mail: vti@vtinh.com

VI TELEFILTER reserves the right to make changes to the product(s) and/or information contained herein without notice. No liability is assumed as a result of their use or application. No rights under any patent accompany the sale of any such product(s) or information.

VI TELEFILTER**Filter Specification****TFS 211 A 3/4****Stability characteristics**

After the following tests the filter shall meet the whole specification:

1. Shock: 30g, 18 ms, half sine wave, 3 shocks each plane;
DIN IEC 68 T2 - 27
2. Vibration: 10 Hz to 150 Hz, 0.35 mm amplitude, 5g; 2 hours for 3 planes;
DIN IEC 68 T2 - 6
3. Damp heat: 90 % to 95 % rel. humidity, 40 °C, 10 days;
(steady state) DIN IEC 68 - 2 - 3
4. Resistance to solder heat (reflow): max. 2 times reflow process;
for temperature conditions refer to the attached "Air reflow temperature conditions" on sheet 4;

Packing

Tape & Reel: DIN IEC 286 - 3, with exception of value for N and minimum bending radius;
tape type II, embossed carrier tape with top cover tape on the upper side;

max. pieces of filters per reel: 1700

Tape (all dimensions in mm)

W	: 24 ± 0,3
Po	: 4 ± 0,1
Do	: 1,5 + 0,5
D1	: 1,5 + 0,5
E	: 1,75 ± 0,1
F	: 11,5 ± 0,1
G (min)	: 0,75
P2	: 2 ± 0,1
P1	: 12 ± 0,1
D1(min)	: 1,5
Ao	: 7,1 ± 0,1
Bo	: 15,9 ± 0,1
Ko	: 2,1 ± 0,1
t	: 0,3 ± 0,05

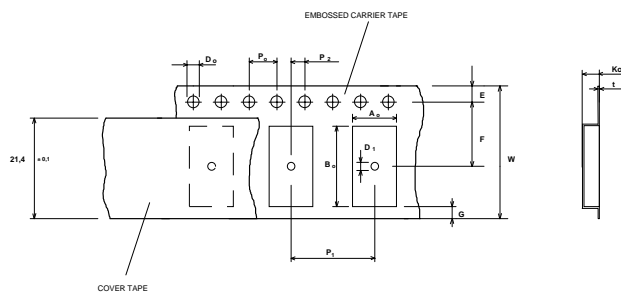
**Reel (all dimensions in mm):**

A	:	330
W1	:	24,4 +2
W2 (max)	:	30,4
N (min)	:	>= 90
C	:	13 ± 0,25

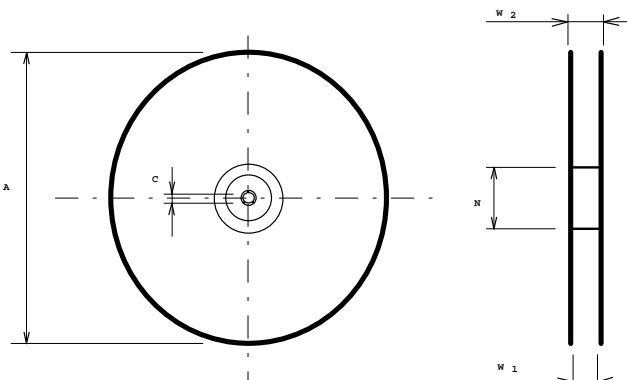

The minimum bending radius is 45 mm. The mounting surface of the filters faces the bottom side of the embossed carrier tape. The marking of the filters is able to read if the view is directed on the upper side of the carrier tape with the sprocket holes on the right side of the tape.

VI TELEFILTER

Potsdamer Straße 18
D 14 513 TELTOW / Germany
Tel: (+49) 3328 4784-52 / Fax: (+49) 3328 4784-30
E-Mail: tft@telefilter.com

Vectron International, Inc.

267 Lowell Road
Hudson, NH 03051 / USA
Tel: (603) 598-0070 Fax: (603) 598-0075
E-Mail: vti@vtinh.com

VI TELEFILTER reserves the right to make changes to the product(s) and/or information contained herein without notice. No liability is assumed as a result of their use or application. No rights under any patent accompany the sale of any such product(s) or information.

VI TELEFILTER**Filter Specification****TFS 211 A 4/4****Air reflow temperature conditions**

1st and 2nd air reflow profile

Name:	pre-heating periods	main-heating periods	peak temperature
Temperature:	150 °C - 170 °C	over 200 °C	230 °C ± 5 °C
Time:	60 sec. - 90 sec.	20 sec. - 25 sec.	

Chip-mount air reflow profile

Table for temperature vs. time during the air reflow process

Tolerance of temperatures: ± 5 °C

time / sec.	temperature / °C	time / sec.	temperature / °C
0	23	140	160
10	34	150	161
20	46	160	164
30	60	170	170
40	80	180	180
50	103	190	200
60	121	195	220
70	134	200	230
80	143	205	220
90	150	210	200
100	154	215	180
110	156	220	165
120	158	230	140
130	159	240	120

VI TELEFILTER
 Potsdamer Straße 18
 D 14 513 TELTOW / Germany
 Tel: (+49) 3328 4784-52 / Fax: (+49) 3328 4784-30
 E-Mail: tft@telefilter.com

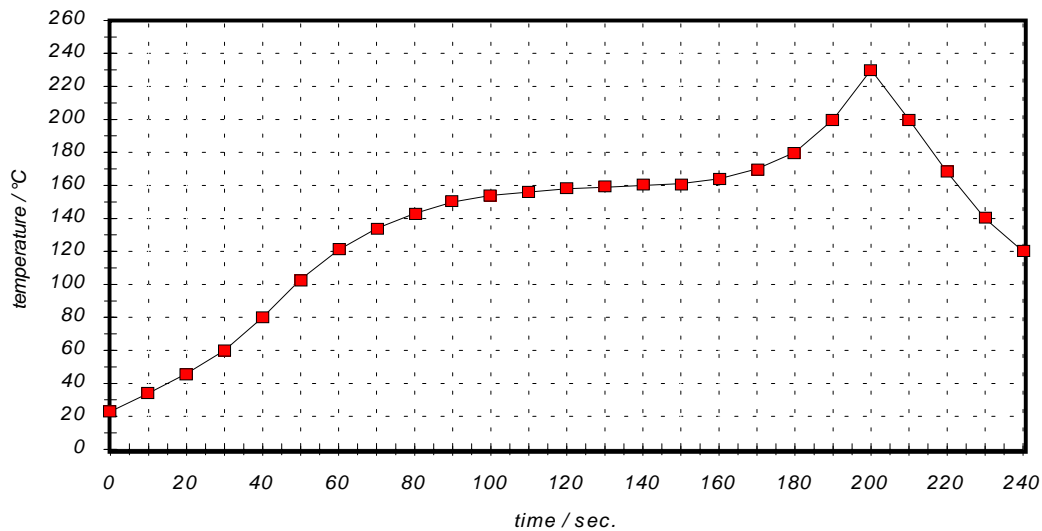
Vectron International, Inc.
 267 Lowell Road
 Hudson, NH 03051 / USA
 Tel: (603) 598-0070 Fax: (603) 598-0075
 E-Mail: vti@vtinh.com

VI TELEFILTER reserves the right to make changes to the product(s) and/or information contained herein without notice. No liability is assumed as a result of their use or application. No rights under any patent accompany the sale of any such product(s) or information.