

VI TELEFILTER**Filter specification****TFS 244 A 1/4****Measurement condition**

Ambient temperature: 23 °C
 Input power level: 0 dBm
 Source impedance: 340 Ω || -5 pF
 Load impedance: 340 Ω || -5 pF
 Ext.coil: 116 nH

Construction and pin connection

see page 2

Characteristics**Remark:**

Reference level for the relative attenuation a_{rel} of the TFS 244,0 is the minimum of the pass band attenuation a_{min} . The minimum of the pass band attenuation a_{min} is defined as the insertion loss a_e . The centre frequency f_0 is the arithmetic mean value of the upper and lower frequencies at the 3 dB filter attenuation level relative to the insertion loss a_e . The nominal frequency f_N is fixed on 244,0 MHz without tolerance. The given values for the relative attenuation a_{rel} and for the group delay ripple have to be reached at the frequencies given below also if the centre frequency f_0 is shifted due to the temperature coefficient of frequency TC_f in the operating temperature range and due to a production tolerance for the centre frequency f_0 .

Preliminary Data		typ. value	tolerance / limit
Insertion loss (Reference level)	$a_e = a_{min}$	3,2 dB	max 5 dB
Normal frequency	f_N		244,0 MHz
Relative attenuation	a_{rel}		
244,0 MHz ± 90 kHz		-	max 3 dB
244,0 MHz ± 400 kHz ... 244,0 MHz ± 600 kHz		-	min 25 dB
244,0 MHz ± 600 kHz ... 244,0 MHz ± 800 kHz		-	min 36 dB
244,0 MHz ± 800 kHz ... 244,0 MHz ± 1,6 MHz		-	min 45 dB
244,0 MHz - 1,6 MHz ... 244,0 MHz - 10 MHz		-	min 50 dB
244,0 MHz + 1,6 MHz ... 244,0 MHz + 15 Mhz		-	min 45 dB
244,0 MHz + 15 MHz ... 244,0 MHz + 25 Mhz		-	min 50 dB
Group delay distortion	GD	2,6 μs	-
244,0 MHz ± 70 kHz		1 μs	max 2 μs
Operating temperature range		- 40 °C ... + 85 °C	
Storage temperature range		- 30 °C ... + 85 °C	
Temperature coefficient of frequency	TC	ca. - 0,036 ppm/K ²	
Frequency inversion temperature		+ 25°C	

Generated:**Checked / approved:**

VI TELEFILTER
 Potsdamer Straße 18
 D 14 513 TELTOW / Germany
 Tel: (+49) 3328 4784-52 / Fax: (+49) 3328 4784-30
 E-Mail: tft@telefilter.com

Vectron International, Inc.
 267 Lowell Road
 Hudson, NH 03051 / USA
 Tel: (603) 598-0070 Fax: (603) 598-0075
 E-Mail: vti@vtinh.com

VI TELEFILTER reserves the right to make changes to the product(s) and/or information contained herein without notice. No liability is assumed as a result of their use or application. No rights under any patent accompany the sale of any such product(s) or information.

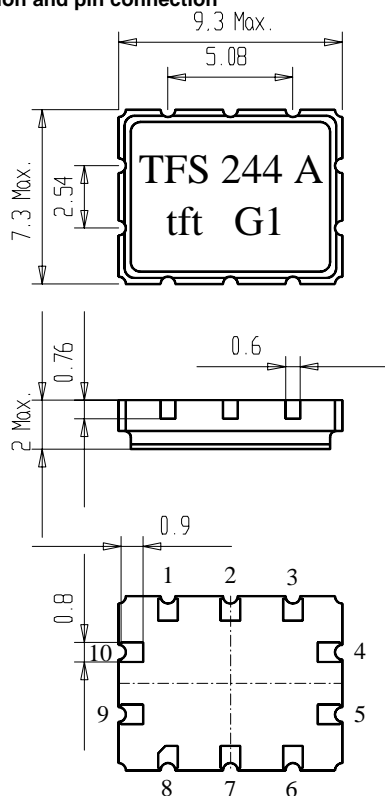
VI TELEFILTER**Filter specification****TFS 244 A 2/4****Construction and pin connection**

- | | |
|------------|-----------|
| 1 Output | 6 Input |
| 2 Ground | 7 Ground |
| 3 Ext.coil | 8 Ground |
| 4 Ground | 9 Ground |
| 5 Ground | 10 Ground |

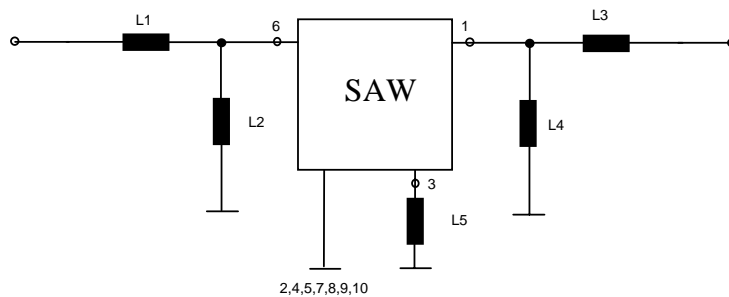
50 Ω test circuit

VI TELEFILTER
 Potsdamer Straße 18
 D 14 513 TELTOW / Germany
 Tel: (+49) 3328 4784-52 / Fax: (+49) 3328 4784-30
 E-Mail: tft@telefilter.com

Vectron International, Inc.
 267 Lowell Road
 Hudson, NH 03051 / USA
 Tel: (603) 598-0070 Fax: (603) 598-0075
 E-Mail: vti@vtinh.com

VI TELEFILTER reserves the right to make changes to the product(s) and/or information contained herein without notice. No liability is assumed as a result of their use or application. No rights under any patent accompany the sale of any such product(s) or information.

VI TELEFILTER**Filter specification****TFS 244 A 3/4****Stability characteristics**

After the following tests the filter shall meet the whole specification:

1. Shock: 30g, 18 ms, half sine wave, 3 shocks each plane;
DIN IEC 68 T2 - 27
2. Vibration: 10 Hz to 150 Hz, 0.35 mm amplitude, 5g; 2 hours for 3 planes;
DIN IEC 68 T2 - 6
3. Damp heat: 90 % to 95 % rel. humidity, 40 °C, 10 days;
IEC Pub. 68 - 2 - 3
4. Resistance to solder heat (Reflow): 260 °C for 10 sec;

Packing

Tape & Reel: DIN IEC 286 - 3, with exception of value for N and minimum bending radius;
tape type II, embossed carrier tape with top cover tape on the upper side;

max. pieces of filters per reel: 2300

Tape (all dimensions in mm)

W	: 16 ± 0,3
Po	: 4 ± 0,1
Do	: 1,5 + 0,5
D1	: 1,5 + 0,5
E	: 1,75 ± 0,1
F	: 7,5 ± 0,1
G (min)	: 0,75
P2	: 2 ± 0,1
P1	: 12 ± 0,1
D1(min)	: 1,5
Ao	: 7,6 ± 0,1
Bo	: 9,6 ± 0,1

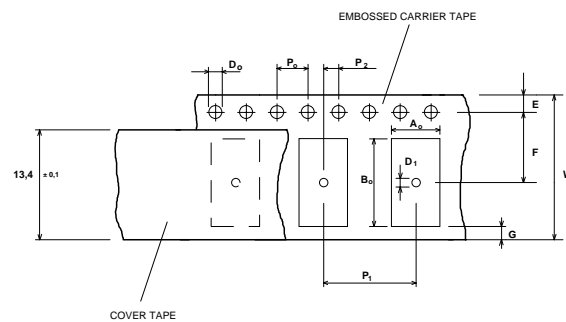
**Reel (all dimensions in mm):**

A	:	330
W1	:	16,4 +2
W2 (max)	:	22,4
N (min)	:	>= 90
C	:	13 ± 0,25

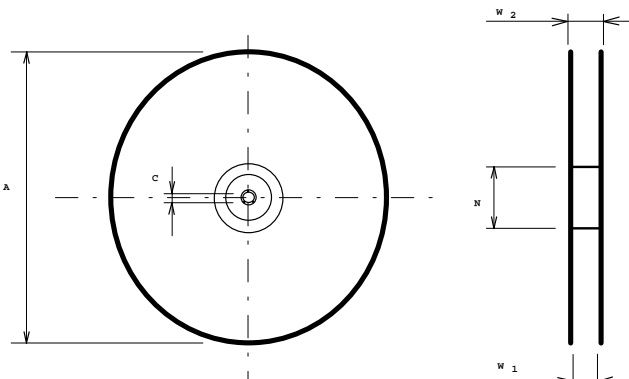

The minimum bending radius is 45 mm. The mounting surface of the filters faces the bottom side of the embossed carrier tape. The marking of the filters is able to read if the view is directed on the upper side of the carrier tape with the sprocket holes on the right side of the tape.

VI TELEFILTER
Potsdamer Straße 18
D 14 513 TELTOW / Germany
Tel: (+49) 3328 4784-52 / Fax: (+49) 3328 4784-30
E-Mail: tft@telefilter.com

Vectron International, Inc.
267 Lowell Road
Hudson, NH 03051 / USA
Tel: (603) 598-0070 Fax: (603) 598-0075
E-Mail: vti@vtinh.com

VI TELEFILTER reserves the right to make changes to the product(s) and/or information contained herein without notice. No liability is assumed as a result of their use or application. No rights under any patent accompany the sale of any such product(s) or information.

Air reflow temperature conditions

1st and 2nd air reflow profile

Name:	pre-heating periods	main-heating periods	peak temperature
Temperature:	150 °C - 170 °C	over 200 °C	255 °C ± 5 °C
Time:	60 sec. - 90 sec.	20 sec. - 25 sec.	

Chip-mount air reflow profile

Table for temperature vs. time during the air reflow process

Tolerance of temperatures: ± 5 °C

time / sec.	temperature / °C	time / sec.	temperature / °C
0	23	140	160
10	34	150	161
20	46	160	164
30	60	170	170
40	80	180	180
50	103	190	205
60	121	195	230
70	134	200	255
80	143	205	230
90	150	210	205
100	154	215	180
110	156	220	165
120	158	230	140
130	159	240	120

VI TELEFILTER
 Potsdamer Straße 18
 D 14 513 TELTOW / Germany
 Tel: (+49) 3328 4784-52 / Fax: (+49) 3328 4784-30
 E-Mail: tft@telefilter.com

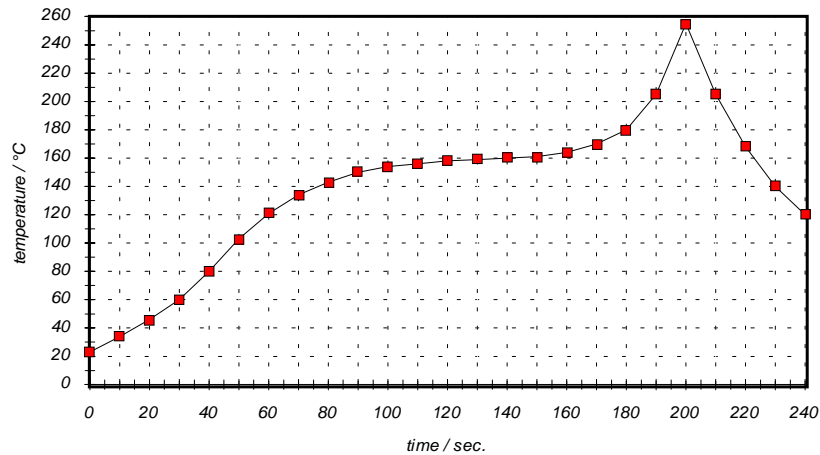
Vectron International, Inc.
 267 Lowell Road
 Hudson, NH 03051 / USA
 Tel: (603) 598-0070 Fax: (603) 598-0075
 E-Mail: vti@vtinh.com

VI TELEFILTER reserves the right to make changes to the product(s) and/or information contained herein without notice. No liability is assumed as a result of their use or application. No rights under any patent accompany the sale of any such product(s) or information.