

## Low EMI Spread Spectrum Multiplier IC (in Die or Package)

### FEATURES

- Spread Spectrum Clock Generator/Multiplier with output selectable from 1x to 8x.
- 10MHz to 240MHz output with output enable.
- 10MHz to 30 MHz reference input frequency accepted from crystal or external clock signal.
- Reduced EMI from Spread Spectrum Modulation, with selectable modulation amplitude for Center Spread, Down Spread or Asymmetric Spread.
- TTL/CMOS compatible outputs.
- 3.3V Operating Voltage.
- 100 ps maximum cycle-to-cycle jitter.
- Available in 16-Pin 150mil SSOP or DIE.

### DESCRIPTIONS

The PLL701-10 is a low EMI Clock Generator and Multiplier for high-speed digital systems. It uses Spread Spectrum Technology (SST) and permits different levels of EMI reduction by selecting the amplitude of the applied SST. The SST feature can be turned off. An output enable input is also used. The chip operates with input frequencies ranging from 10 to 30 MHz and provides 1x to 8x at its output.

### OUTPUT CLOCK (FOUT) SELECTION

M2	M1	M0	FIN/XIN (MHz)	Multiplier	FOUT (MHz)
0	0	0	10 ~ 30	X1	10 ~ 30
0	0	1		X2	20 ~ 60
0	1	0		X3	30 ~ 90
0	1	1		X4	40 ~ 120
1	0	0		X5	50 ~ 150
1	0	1		X6	60 ~ 180
1	1	0		X7	70 ~ 210
1	1	1		X8	80 ~ 240

### BLOCK DIAGRAM

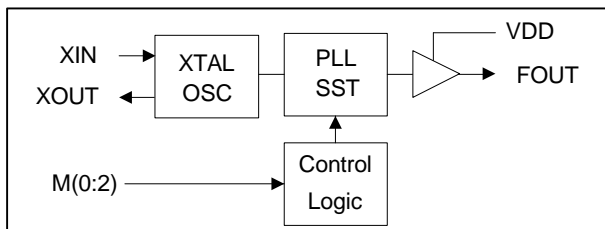

### PACKAGE PIN CONFIGURATION

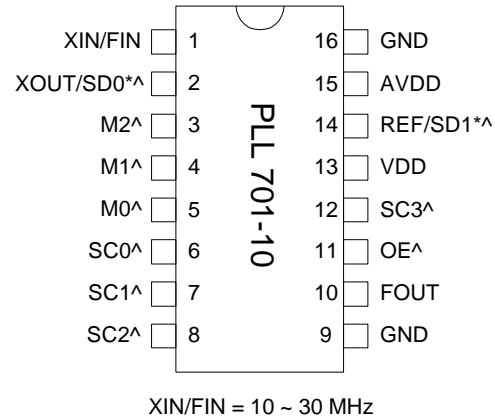

### DIE PAD CONFIGURATION

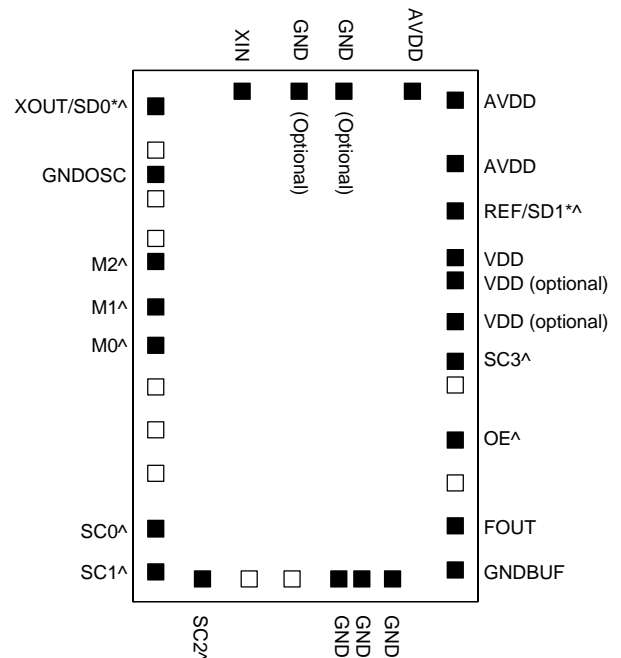

**Note:** ^: Internal pull-up resistor (120kΩ for SD0, 30 kΩ for SC0-SC2, SD1, M0-M2 and OE). The internal pull-up resistor results in a default high value when no pull-down resistor is connected to this pin.

\*: SD0 and SD1 are latched upon power-up.

**Low EMI Spread Spectrum Multiplier IC (in Die or Package)**
**SPREAD SPECTRUM SELECTION TABLE**

SD1	SD0	SC3	SC2	SC1	SC0	Modulation Magnitude	Modulation Frequency	Modulation Type
1	1	0	0	0	0	0.250%	Fin / 512	C ± 0.125%
1	1	0	0	0	1	0.500%		C ± 0.25%
1	1	0	0	1	0	0.750%		C ± 0.375%
1	1	0	0	1	1	1.000%		C ± 0.50%
1	0	0	0	1	1			D -1.00%
1	1	0	1	0	0	1.250%		C ± 0.625%
1	0	0	1	0	0			A +0.125 ~ -1.125%
1	1	0	1	0	1	1.500%		C ± 0.75%
1	0	0	1	0	1			A +0.25 ~ -1.25%
1	1	0	1	1	0	1.750%		C ± 0.875%
1	0	0	1	1	0			A +0.375 ~ -1.375%
1	1	0	1	1	1	2.000%		C ± 1.00%
1	0	0	1	1	1			A +0.50 ~ -1.5%
0	1	0	1	1	1			D -2.00%
1	1	1	0	0	0	2.250%		C ± 1.125%
1	0	1	0	0	0			A +0.625 ~ -1.625%
0	1	1	0	0	0			A +0.125 ~ -2.125%
1	1	1	0	0	1	2.500%		C ± 1.25%
0	1	1	0	0	1			A +0.25 ~ -2.25%
1	0	1	0	0	1			A +0.75 ~ -1.75%
1	1	1	0	1	0	2.750%	C ± 1.375%	
1	0	1	0	1	0		A +0.875 ~ -1.875%	
0	1	1	0	1	0		A +0.375 ~ -2.375%	
1	1	1	0	1	1	3.000%	C ± 1.50%	
0	0	1	0	1	1		D -3.00%	
1	0	1	0	1	1		A +1.00 ~ -2.00%	
0	1	1	0	1	1		A +0.50 ~ -2.50%	
1	1	1	1	0	0	3.250%	C ± 1.625%	
1	0	1	1	0	0		A +1.125 ~ -2.125%	
0	1	1	1	0	0		A +0.625 ~ -2.625%	
0	0	1	1	0	0		A +0.125 ~ -3.125%	
1	1	1	1	0	1	3.500%	C ± 1.75%	
1	0	1	1	0	1		A +1.25 ~ -2.25%	
0	1	1	1	0	1		A +0.75 ~ -2.75%	
0	0	1	1	0	1		A +0.25 ~ -3.25%	
1	1	1	1	1	0	3.750%	C ± 1.875%	
1	0	1	1	1	0		A +1.37 ~ -2.375%	
0	1	1	1	1	0		A +0.875 ~ -2.875%	
0	0	1	1	1	0		A +0.375 ~ -3.375%	
1	1	1	1	1	1	0.00 %	SST turned off	
1	0	1	1	1	1		SST turned off	
0	1	1	1	1	1		SST turned off	
0	0	1	1	1	1		SST turned off	

Notes: C: Center Spread. A: Asymmetric Spread. D: Down Spread.

**Low EMI Spread Spectrum Multiplier IC (in Die or Package)**
**PIN/PAD DESCRIPTIONS**

Name	Pin #	Pad #	Type	Description
XIN/FIN	1	22	I	Crystal input to be connected to fundamental parallel mode crystal. ( $C_L=20\text{pF}$ ) or clock input.
XOUT/SD0	2	23	B	At power-up, this pin is acts as input pin to select the modulation rate and is latched in. After the input sampling, it is used as crystal output connector. $120\text{k}\Omega$ internal pull up resistor.
M2	3	28	I	Digital control input to select output frequency. $30\text{k}\Omega$ internal pull-up.
M1	4	29	I	Digital control input to select output frequency. $30\text{k}\Omega$ internal pull-up.
M0	5	30	I	Digital control input to select output frequency. $30\text{k}\Omega$ internal pull-up.
SC0	6	34	I	Digital control input to select spread spectrum modulation. $30\text{k}\Omega$ internal pull-up.
SC1	7	35	I	Digital control input to select spread spectrum modulation. $30\text{k}\Omega$ internal pull-up.
SC2	8	1	I	Digital control input to select spread spectrum modulation. $30\text{k}\Omega$ internal pull-up.
SC3	12	12	I	Digital control input to select spread spectrum modulation. $30\text{k}\Omega$ internal pull-up.
FOUT	10	8	O	Modulated Clock Frequency Output. The frequency before modulation is synthesized by multiplying the input frequency by 1X to 8X, depending on SD(0:1) and SC(0:3).
OE	11	10	I	Output Enable. When low, Tri-states all outputs. $30\text{k}\Omega$ internal pull-up.
VDD	13	13,14,15	P	3.3V Power Supply.
REF/SD1	14	16	B	At power-up, this pin acts as input pin to select the modulation rate and is latched in. After the input sampling, this pin provides a buffered Reference Clock Output of the same frequency as the crystal or clock input. $30\text{k}\Omega$ internal pull-up.
AVDD	15	17,18,19	P	3.3V Analog power supply.
GNDOSC	N/A	25	P	Ground for Oscillator circuitry.
GNDBUF	N/A	7	P	Ground for output buffer circuitry.
GND	9 and 16	4,5,6,20,21	P	Ground.

Notes: B – bi-directional pin; I – input pin; P – power supply/ground pin.

## Low EMI Spread Spectrum Multiplier IC (in Die or Package)

### FUNCTIONAL DESCRIPTION

#### Selectable spread spectrum and modulation rates

The PLL701-10 provides selectable multiplier factors (1x to 8X), selectable spread spectrum modulation, as well as selectable modulation rate. Selection is made by connecting specific input pins to a logical "zero" or "one". Pins 6 (SC0), 7 (SC1), 8 (SC2) and 12 (SC3) are used as inputs to select the spread spectrum modulation as shown on the spread spectrum selection table (page 2). Pins 3 (M2), 4 (M1), 5 (M0) are used as inputs to select the output frequency as shown on the output clock selection table (page 1). Pin 11 is the output enable pin, that tri-states all outputs when low (logical "zero").

In order to reduce the number of pins on the chip, the PLL701-10 uses pin 2 and 14 (XOUT/SD0 and REF/SD1) as a bi-directional pin. The pins serve as modulation rate selector inputs (SD0 and SD1) upon power-up (see modulation rate table on page 1), and as XOUT crystal connection (pin 2), and REF output signal (pin 14) as soon as the inputs have been latched.

#### Connecting a selection pin to a logical "one"

All selection pins have an internal pull-up resistor (30kΩ for pins 3, 4, 5, 6, 7, 8, 11, 12, 14 and 120kΩ for pin 2). This internal pull-up resistor will pull the input value to a logical "one" (pull-up) by default, i.e. when no resistive load is connected between the pin and GND. No external pull-up resistor is therefore required for connecting a logical "one" upon power-up.

#### Connecting a selection pin to a logical "zero"

For an input only pin, i.e. all input pins except XOUT/SD0 (pin 2) and REF/SD1 (pin 14), the pin simply needs to be grounded to pull the input down to a logical "zero". Connecting the bi-directional pins (SD0 and SD1) to a logical "zero" will however require the use of an external loading resistor between the pin and GND that has to be sufficiently small (compared to the internal pull-up resistor) so that the pin voltage be pulled below 0.8V (logical "zero"). In order to avoid loading effects when the pin serves as output, the value of the external pull-down resistor should however be kept as large as possible. In general, it is recommended to use an external resistor of around  $R_{up}/4$  (e.g. 27kΩ for pin 2 and 4.7kΩ for pin 14, see Application Diagram).

### APPLICATION DIAGRAM FOR OUTPUT AND MODULATION SELECTION

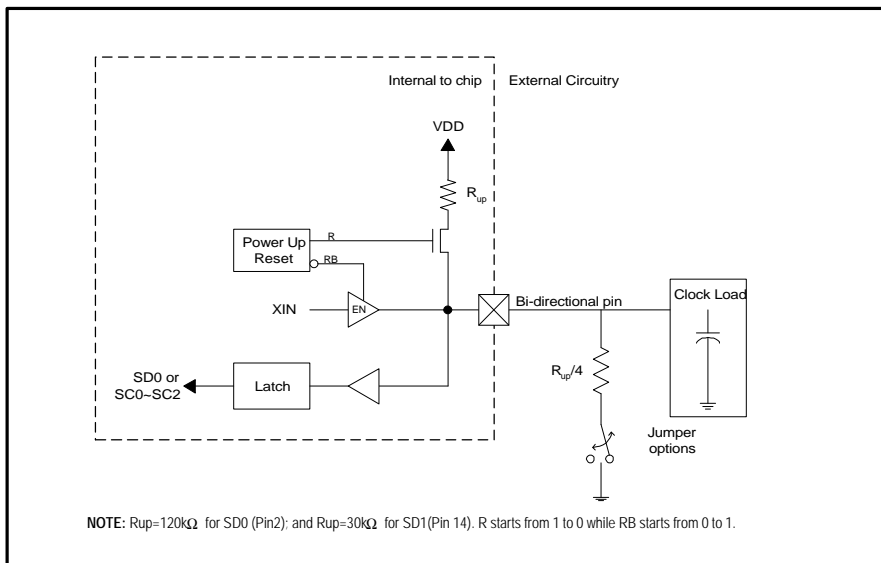

## Low EMI Spread Spectrum Multiplier IC (in Die or Package)

### ELECTRICAL SPECIFICATIONS

#### 1. Absolute Maximum Ratings

PARAMETERS	SYMBOL	MIN.	MAX.	UNITS
Supply Voltage	$V_{DD}$	$V_{SS}-0.5$	6	V
Input Voltage Range	$V_I$	$V_{SS}-0.5$	$V_{DD}+0.5$	V
Output Voltage Range	$V_O$	$V_{SS}-0.5$	$V_{DD}+0.5$	V
Soldering Temperature			260	°C
Storage Temperature	$T_S$	-65	150	°C
Ambient Operating Temperature*	$T_A$	-40	85	°C

Exposure of the device under conditions beyond the limits specified by Maximum Ratings for extended periods may cause permanent damage to the device and affect product reliability. These conditions represent a stress rating only, and functional operations of the device at these or any other conditions above the operational limits noted in this specification is not implied.

\* **Note:** Operating Temperature is guaranteed by design for all parts (COMMERCIAL and INDUSTRIAL), but tested for INDUSTRIAL grade only.

#### 2. DC/AC Specification

PARAMETERS	SYMBOL	CONDITIONS	MIN.	TYP.	MAX.	UNITS
Supply Voltage	$V_{DD}$		3.15		3.45	V
Input High Voltage	$V_{IH}$		$0.7 \cdot V_{DD}$			V
Input Low Voltage	$V_{IL}$				$0.3 \cdot V_{DD}$	V
Input High Current	$I_{IH}$				100	$\mu A$
Input Low Current	$I_{IL}$				100	$\mu A$
Output High Voltage	$V_{OH}$	$I_{OH}=5mA, V_{DD}=3.3V$	2.4			
Output Low Voltage	$V_{OL}$	$I_{OL}=6mA, V_{DD}=3.3V$			0.4	
Input Frequency	$F_{XIN}$	When using a crystal	15		30	MHz
	$F_{IN}$	When using reference clock	15		30	MHz
Maximum interruption of $F_{IN}$		When using reference clock			100	$\mu s$
Load Capacitance	$C_L$	Between Pin XIN and XOUT*		18		pF
Pull-up Resistor	$R_{up}$	PIN 2		120		$k\Omega$
Pull-up Resistor	$R_{up}$	PIN 3,4,5,6,7,8,11,12		30		$k\Omega$
Short Circuit Current	$I_{sc}$			25		mA
3.3V Dynamic Supply Current	$I_{CC}$	No Load		20		mA

\***Note:** Pin XIN and XOUT each has a 36pF capacitance. When used with a XTAL, the two capacitors combined load the crystal with 18pF. If driving XIN with a reference clock signal, the load capacitance will be 36pF (typical).

**Low EMI Spread Spectrum Multiplier IC (in Die or Package)**
**3. TIMING CHARACTERISTICS**

PARAMETERS	SYMBOL	CONDITIONS	MIN.	TYP.	MAX.	UNITS
Rise Time	$T_r$	Measured at 0.8V ~ 2.0V @ 3.3V	0.8	0.95	1.1	ns
Fall Time	$T_f$	Measured at 2.0V ~ 0.8V @ 3.3V	0.78	0.85	0.9	ns
Output Duty Cycle	$D_T$		45	50	55	%
Cycle to Cycle Jitter	$T_{cyc-cyc}$	FOUT=48MHz @ 3.3V			100	ps
Cycle to Cycle Jitter	$T_{cyc-cyc}$	FOUT=72MHz @ 3.3V			100	ps

**Low EMI Spread Spectrum Multiplier IC (in Die or Package)**
**PAD ASSIGNMENT** (LOWER LEFT CORNER: X = 0, Y = 0)

Pad #	Name	X ( $\mu\text{m}$ )	Y ( $\mu\text{m}$ )
1	SC2	338.9	104.7
2	N/C	569	104.7
3	N/C	780.5	104.7
4	GND	1027.6	104.7
5	GND	1127.3	104.7
6	GND	1284.5	104.7
7	GNDBUF	1595.1	139.7
8	FOUT	1595.1	381.7
9	N/C	1595.1	596.3
10	OE	1595.1	811.9
11	N/C	1595.1	970.3
12	SC3	1595.1	1069.3
13	VDD (Optional)	1595.1	1312.3
14	VDD (Optional)	1595.1	1555.6
15	VDD	1595.1	1656.8
16	REF/SD1	1595.1	1879.9
17	AVDD	1595.1	2093
18	AVDD	1595.1	2390.6
19	AVDD	1369.2	2435
20	GND (Optional)	1037.3	2435
21	GND (Optional)	824.7	2435
22	XIN	529.7	2435
23	XOUT/SD0	105.6	2343.5
24	N/C	105.6	2136.1
25	GNDOSC	105.6	2035.6
26	N/C	105.6	1934.9
27	N/C	105.6	1741.5
28	M2	105.6	1641.4
29	M1	105.6	1396.2
30	N/C	105.6	1180.3
31	N/C	105.6	993.5
32	N/C	105.6	836.7
33	N/C	105.6	680.1
34	SC0	105.6	354.9
35	SC1	105.6	110.7

**Low EMI Spread Spectrum Multiplier IC (in Die or Package)**

**PACKAGE INFORMATION (DIE INFORMATION TO BE ADDED)**

16 PIN SSOP

Symbol	mm		BSC	
	Min.	Max.	Min.	Max.
A	1.35	1.75	0.053	0.069
A1	0.10	0.25	0.004	0.010
B	0.20	0.30	0.008	0.012
C	0.18	0.25	0.007	0.010
D	4.80	5.00	0.189	0.197
E	3.81	3.99	0.150	0.157
H	5.79	6.20	0.228	0.244
L	0.41	1.27	0.016	0.050
e	0.635 BASIC		0.025 BASIC	

**ORDERING INFORMATION**

**For part ordering, please contact our Sales Department:**  
47745 Fremont Blvd., Fremont, CA 94538, USA  
Tel: (510) 492-0990 Fax: (510) 492-0991

**PART NUMBER**

The order number for this device is a combination of the following:  
Device number, Package type and Operating temperature range

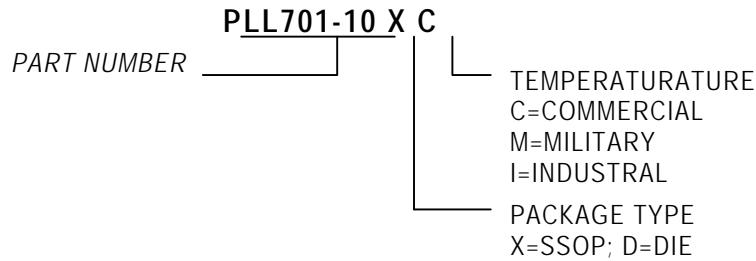

*PhaseLink Corporation, reserves the right to make changes in its products or specifications, or both at any time without notice. The information furnished by Phaselink is believed to be accurate and reliable. However, PhaseLink makes no guarantee or warranty concerning the accuracy of said information and shall not be responsible for any loss or damage of whatever nature resulting from the use of, or reliance upon this product.*

**LIFE SUPPORT POLICY:** PhaseLink's products are not authorized for use as critical components in life support devices or systems without the express written approval of the President of PhaseLink Corporation.