

8A, 60V, 0.300 Ohm, ESD Rated, Logic Level, P-Channel Power MOSFET

These products are P-Channel power MOSFETs manufactured using the MegaFET process. This process, which uses feature sizes approaching those of LSI circuits, gives optimum utilization of silicon, resulting in outstanding performance. They were designed for use in applications such as switching regulators, switching converters, motor drivers, and relay drivers. These transistors can be operated directly from integrated circuits.

Formerly developmental type TA49203.

Ordering Information

PART NUMBER	PACKAGE	BRAND
RFD8P06LE	TO-251AA	F8P6LE
RFD8P06LESM	TO-252AA	F8P6LE
RFP8P06LE	TO-220AB	FP8P06LE

NOTE: When ordering, use the entire part number. Add the suffix 9A to obtain the TO-252AA variant in the tape and reel, i.e., RFD8P06LESM9A.

Features

- 8A, 60V
- $r_{DS(ON)} = 0.300\Omega$
- 2kV ESD Protected
- Temperature Compensating PSPICE® Model
- PSPICE Thermal Model
- Peak Current vs Pulse Width Curve
- UIS Rating Curve
- 175°C Operating Temperature

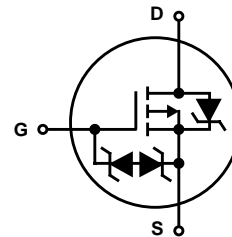
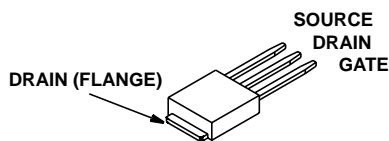
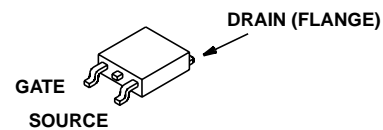
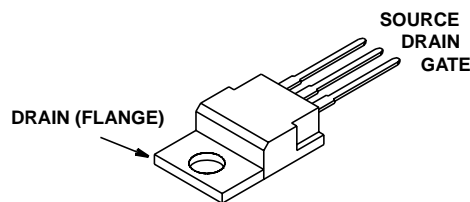
Symbol

Packaging
JEDEC TO-251AA

JEDEC TO-252AA

JEDEC TO-220AB

RFD8P06LE, RFD8P06LESM, RFP8P06LE

Absolute Maximum Ratings $T_C = 25^\circ\text{C}$ Unless Otherwise Specified

	RFD8P06LE, RFD8P06LESM, RFP8P06LE	UNITS
Drain to Source Voltage	-60	V
Drain to Gate Voltage ($R_{GS} = 20\text{k}\Omega$)	-60	V
Continuous Drain Current		
$T_C = 25^\circ\text{C}$	-8	A
$T_C = 100^\circ\text{C}$	-6.3	A
Pulsed Drain Current	See Figure 5	
Gate to Source Voltage	± 10	V
Maximum Power Dissipation	48	W
Dissipation Derating Factor	0.32	W/ $^\circ\text{C}$
Single Pulse Avalanche Energy Rating	See Figure 6	
Operating and Storage Temperature	-55 to 175	$^\circ\text{C}$
Maximum Lead Temperature for Soldering (0.063in (1.6mm) from case for 10s)	300	$^\circ\text{C}$

CAUTION: Stresses above those listed in "Absolute Maximum Ratings" may cause permanent damage to the device. This is a stress only rating and operation of the device at these or any other conditions above those indicated in the operational sections of this specification is not implied.

NOTE:

1. $T_J = 25^\circ\text{C}$ to 150°C .

Electrical Specifications $T_C = 25^\circ\text{C}$ Unless Otherwise Specified

PARAMETER	SYMBOL	TEST CONDITIONS	MIN	TYP	MAX	UNITS	
Drain to Source Breakdown Voltage	BV_{DSS}	$I_D = 250\mu\text{A}$, $V_{GS} = 0\text{V}$ (Figure 11)	-60	-	-	V	
Gate Threshold Voltage	$V_{GS(TH)}$	$V_{GS} = V_{DS}$, $I_D = 250\mu\text{A}$ (Figure 12)	-1	-	-2	V	
Zero Gate Voltage Drain Current	I_{DSS}	$V_{DS} = -60\text{V}$, $V_{GS} = 0\text{V}$	$T_J = 25^\circ\text{C}$	-	-	-1	μA
			$T_J = 150^\circ\text{C}$	-	-	-50	μA
Gate to Source Leakage Current	I_{GSS}	$V_{GS} = \pm 10\text{V}$	-	-	± 10	μA	
On Resistance (Note 1)	$r_{DS(ON)}$	$I_D = 8\text{A}$, $V_{GS} = -5\text{V}$ (Figure 9, 10)	-	-	0.300	Ω	
		$I_D = 8\text{A}$, $V_{GS} = -4.5\text{V}$ (Figure 9, 10)	-	-	0.330	Ω	
Turn-On Time	t_{ON}	$V_{DD} = -30\text{V}$, $I_D \cong 8\text{A}$, $R_{GS} = 9.1\Omega$, $R_L = 3.75\Omega$ (Figure 13)	-	-	90	ns	
Turn-On Delay Time	$t_{d(ON)}$		-	10	-	ns	
Rise Time	t_r		-	50	-	ns	
Turn-Off Delay Time	$t_{d(OFF)}$		-	30	-	ns	
Fall Time	t_f		-	20	-	ns	
Turn-Off Time	t_{OFF}		-	-	75	ns	
Total Gate Charge	$Q_g(TOT)$		$V_{GS} = 0$ to -10V	-	25	30	nC
Gate Charge at -5V	$Q_g(-5)$	$V_{GS} = 0$ to -5V	-	15	18	nC	
Threshold Gate Charge	$Q_g(TH)$	$V_{GS} = 0$ to -1V	-	1.2	1.5	nC	
Input Capacitance	C_{ISS}	$V_{DS} = -25\text{V}$, $V_{GS} = 0\text{V}$, $f = 1\text{MHz}$ (Figure 15)	-	675	-	pF	
Output Capacitance	C_{OSS}		-	175	-	pF	
Reverse Transfer Capacitance	C_{RSS}		-	50	-	pF	
Thermal Resistance Junction to Case	$R_{\theta JC}$		-	-	3.125	$^\circ\text{C/W}$	
Thermal Resistance Junction to Ambient	$R_{\theta JA}$	TO-251AA, TO-252AA	-	-	100	$^\circ\text{C/W}$	
		TO-220AB	-	-	80	$^\circ\text{C/W}$	

Source to Drain Diode Specifications $T_C = 25^\circ\text{C}$ Unless Otherwise Specified

PARAMETER	SYMBOL	TEST CONDITIONS	MIN	TYP	MAX	UNITS
Source to Drain Diode Voltage (Note 1)	V_{SD}	$T_J = 25^\circ\text{C}$, $I_{SD} = -8\text{A}$, $V_{GS} = 0\text{V}$	-	-	-1.5	V
Reverse Recovery Time	t_{rr}	$T_J = 25^\circ\text{C}$, $I_{SD} = -8\text{A}$, $di_{SD}/dt = 100\text{A}/\mu\text{s}$	-	-	125	ns

NOTE:

2. Pulse Test: Pulse width $\leq 300\mu\text{s}$, Duty Cycle $\leq 2\%$.

Typical Performance Curves Unless Otherwise Specified

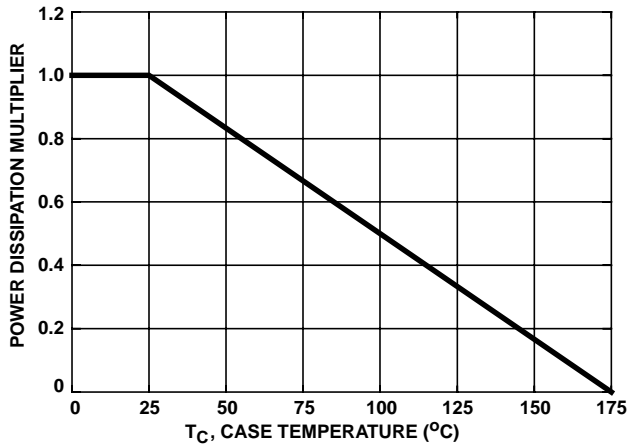

FIGURE 1. NORMALIZED POWER DISSIPATION vs CASE TEMPERATURE

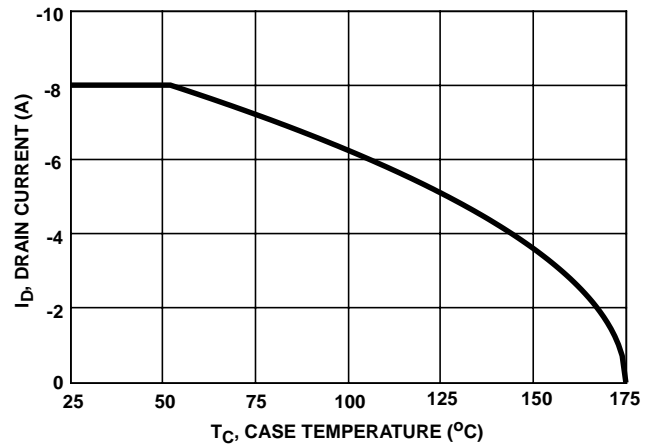

FIGURE 2. MAXIMUM CONTINUOUS DRAIN CURRENT vs CASE TEMPERATURE

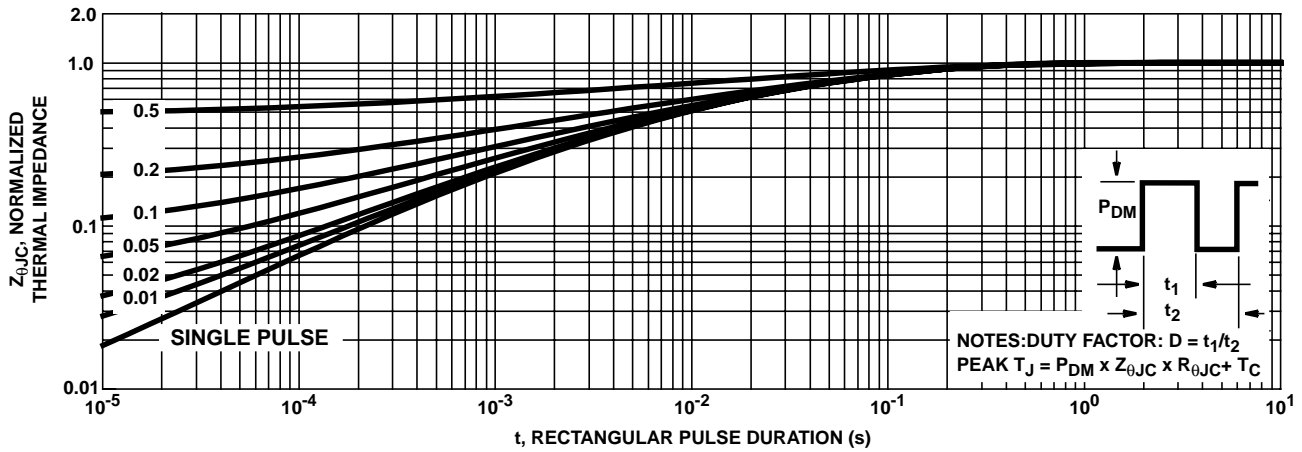

FIGURE 3. NORMALIZED MAXIMUM TRANSIENT THERMAL IMPEDANCE

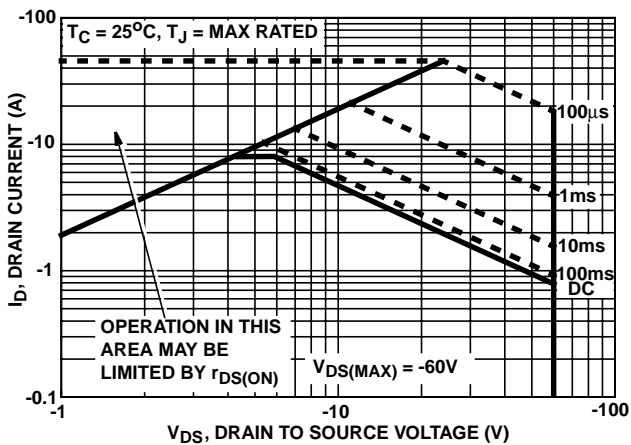

FIGURE 4. FORWARD BIAS SAFE OPERATING AREA

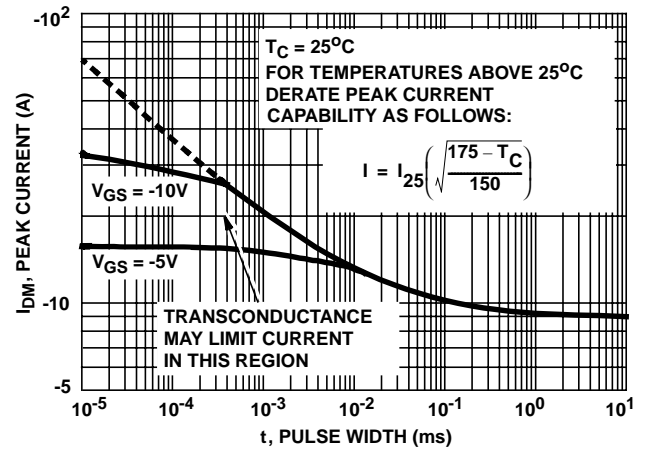
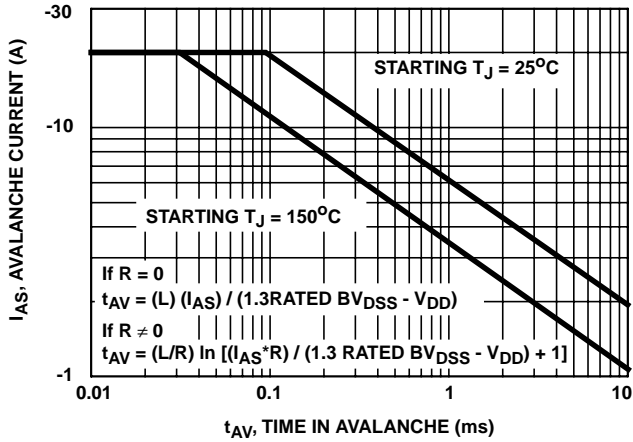

FIGURE 5. PEAK CURRENT CAPABILITY

Typical Performance Curves Unless Otherwise Specified



NOTE: Refer to Intersil Application Notes AN9321 and AN9322.
FIGURE 6. UNCLAMPED INDUCTIVE SWITCHING CAPABILITY

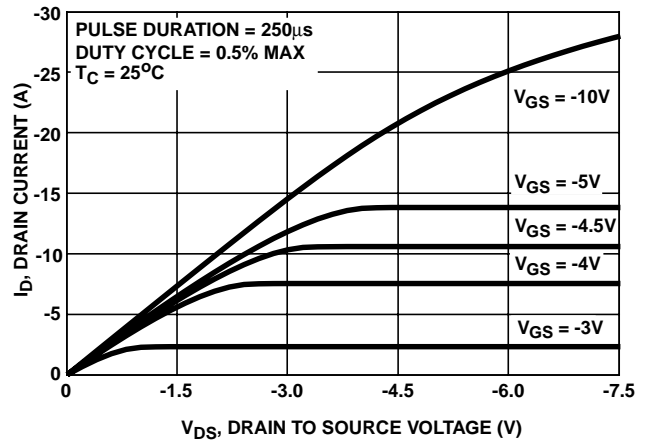

FIGURE 7. SATURATION CHARACTERISTICS

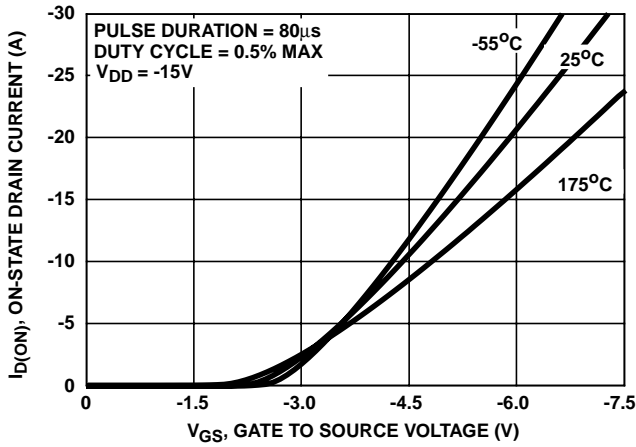

FIGURE 8. TRANSFER CHARACTERISTICS

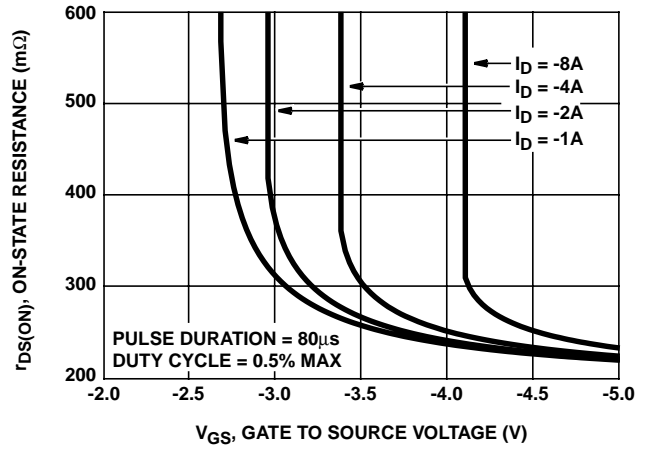

FIGURE 9. DRAIN TO SOURCE ON RESISTANCE vs GATE VOLTAGE AND DRAIN CURRENT

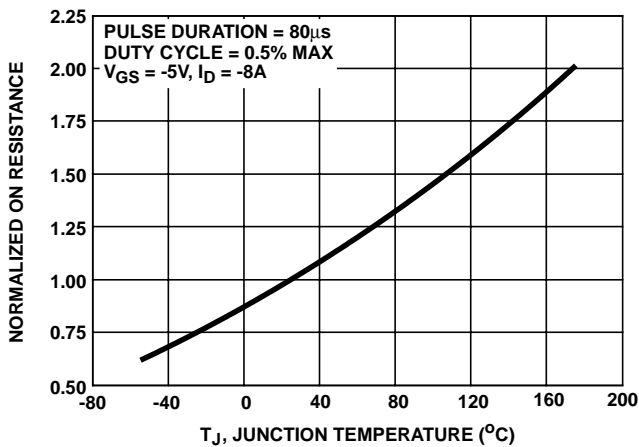

FIGURE 10. NORMALIZED DRAIN TO SOURCE ON RESISTANCE vs JUNCTION TEMPERATURE

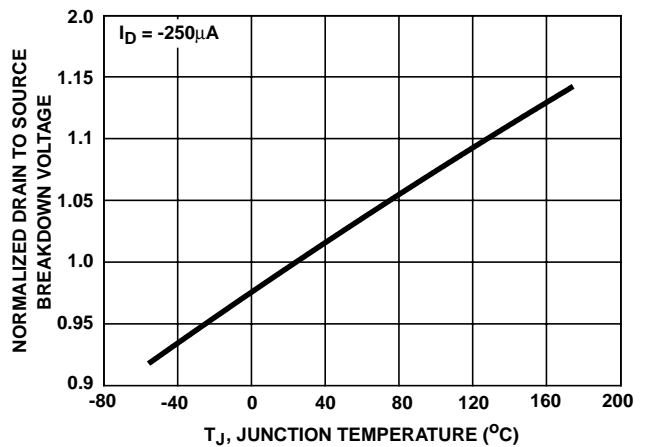

FIGURE 11. NORMALIZED DRAIN TO SOURCE BREAKDOWN VOLTAGE vs JUNCTION TEMPERATURE

Typical Performance Curves Unless Otherwise Specified

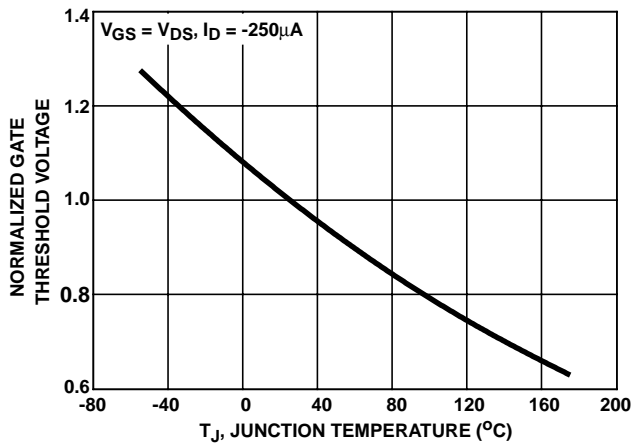

FIGURE 12. NORMALIZED GATE THRESHOLD VOLTAGE vs JUNCTION TEMPERATURE

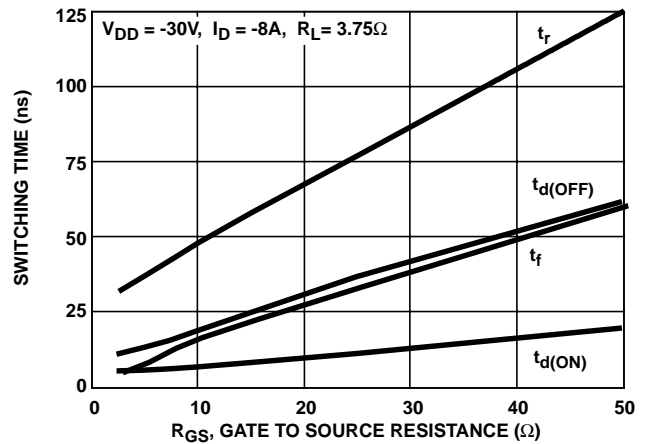
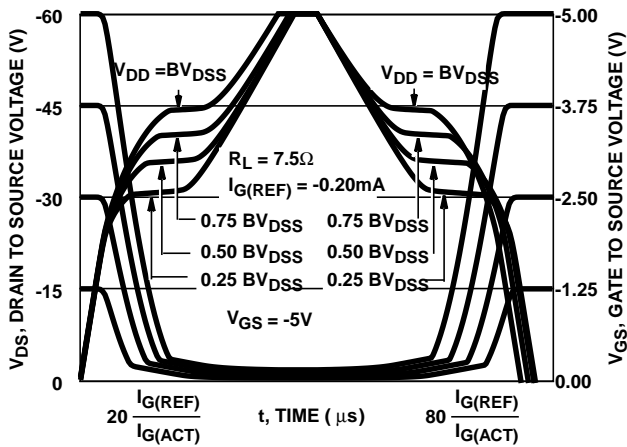

FIGURE 13. SWITCHING TIME AS A FUNCTION OF GATE RESISTANCE



NOTE: Refer to Intersil Application Notes AN7254 and AN7260.

FIGURE 14. NORMALIZED SWITCHING WAVEFORMS FOR CONSTANT GATE CURRENT

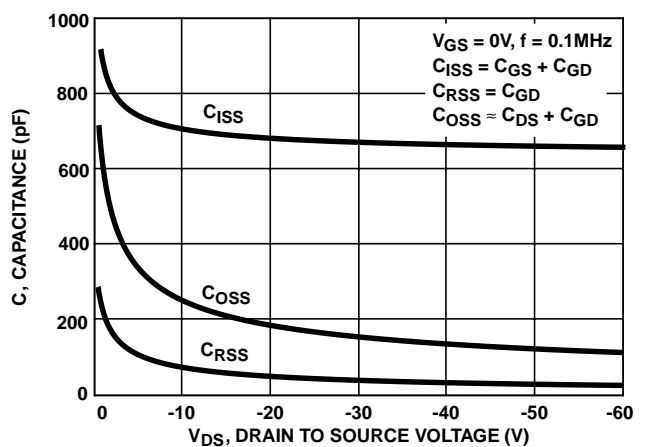

FIGURE 15. CAPACITANCE vs DRAIN TO SOURCE VOLTAGE

Test Circuits and Waveforms

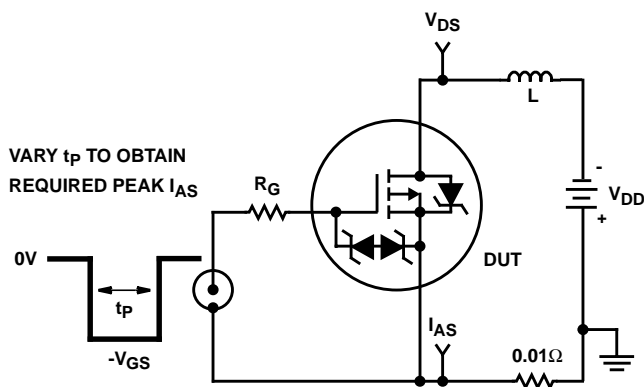

FIGURE 16. UNCLAMPED ENERGY TEST CIRCUIT

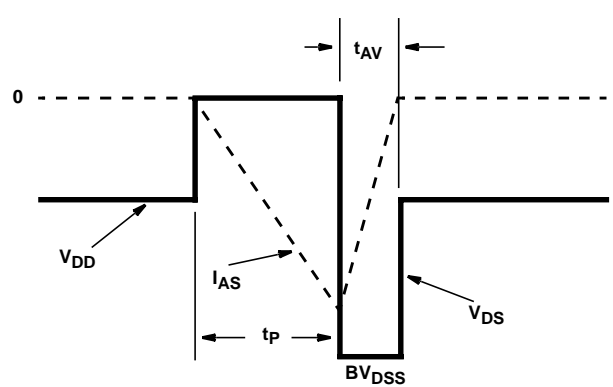

FIGURE 17. UNCLAMPED ENERGY WAVEFORMS

Test Circuits and Waveforms (Continued)

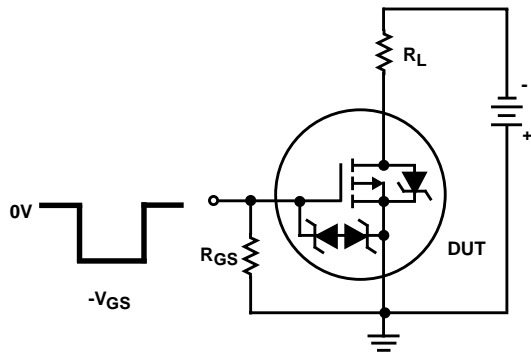

FIGURE 18. SWITCHING TIME TEST CIRCUIT

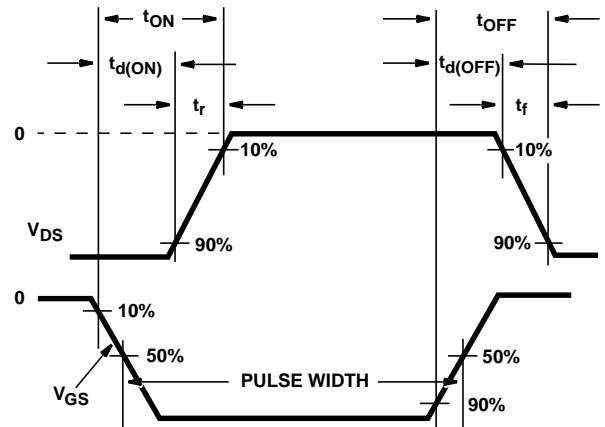

FIGURE 19. RESISTIVE SWITCHING WAVEFORMS

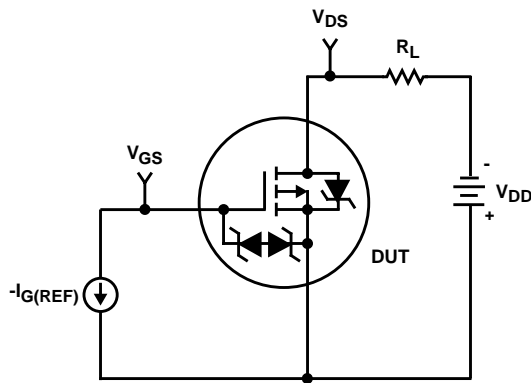

FIGURE 20. GATE CHARGE TEST CIRCUIT

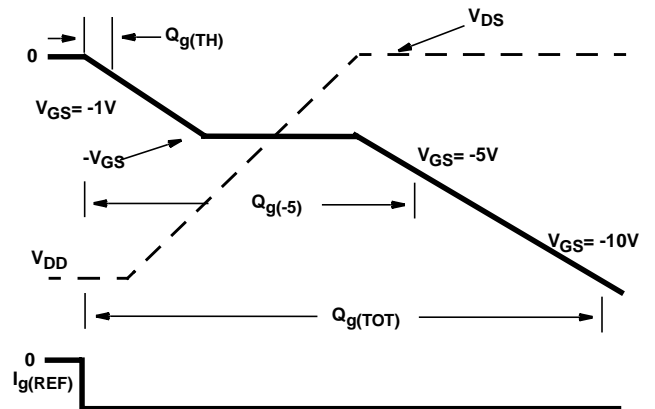

FIGURE 21. GATE CHARGE WAVEFORMS

PsPice Electrical Model

.SUBCKT RFD8P06LE 2 1 3 REV 7/29/96

CA 12 8 1.50e-9
 CB 15 14 1.50e-9
 CIN 6 8 6.30e-10

DBODY 5 7 DBDMOD
 DBREAK 7 11 DBKMOD
 DESD1 91 9 DESD1MOD
 DESD2 91 7 DESD2MOD
 DPLCAP 10 6 DPLCAPMOD

EBREAK 5 11 17 18 -67.9
 EDS 14 8 5 8 1
 EGS 13 8 6 8 1
 ESG 5 10 8 6 1
 EVTHRES 21 6 19 8 1
 EVTEMP 6 20 18 22 1

IT 8 17 1

LDRAIN 2 5 1e-10
 LGATE 1 9 2.92e-9
 LSOURCE 3 7 2.92e-9

MSTRONG 16 6 8 8 MstrongMOD
 MMED 16 6 8 8 MmedMOD
 MWEAK 16 21 8 8 MweakMOD

RBREAK 17 18 RBKMOD 1
 RDRAIN 50 16 RDSMOD 95e-3
 RGATE 9 20 2.89
 RIN 6 8 1e9
 RSCL1 5 51 RSCLMOD 1e-6
 RSCL2 5 50 1e3
 RSOURCE 8 7 RSourceMOD 97e-3
 RVTHRES 22 8 RVTHRESMOD 1
 RVTEMP 18 19 RVTEMPMOD 1

S1A 6 12 13 8 S1AMOD
 S1B 13 12 13 8 S1BMOD
 S2A 6 15 14 13 S2AMOD
 S2B 13 15 14 13 S2BMOD

VBAT 22 19 DC 1

ESCL 51 50 VALUE={{(V(5,51)/ABS(V(5,51)))*(PWR(V(5,51)*1e6/26,7))}}

.MODEL DBDMOD D (IS=2.5e-12 RS=4e-2 IKF=0.01 N=0.97 TIKF=0.012 TRS1=0.8e-4 TRS2=-5e-6 CJO=5.25e-10 VJ=0.75 M=0.41 TT=7.50e-8)
 .MODEL DBKMOD D (IKF=5 N=0.75 RS=0.245 TRS1=1e-3 TRS2=1.6e-4)
 .MODEL DESD1MOD D (BV=16.4 TBV1=-1.25e-3 TBV2=5.79e-7 RS=36 NBV=50 IBV=7e-6)
 .MODEL DESD2MOD D (BV=16.2 TBV1=-8.3e-4 TBV2=8.9e-7 NBV=50 IBV=7e-6)
 .MODEL DPLCAPMOD D (CJO=4.25e-10 IS=1e-30 N=10 VJ=0.499 M=0.561)
 .MODEL MSTRONGMOD PMOS (VTO=-1.91 KP=11.55 IS=1e-30 N=10 TOX=1 L=1u W=1u)
 .MODEL MMEDMOD PMOS (VTO=-1.51 KP=0.95 IS=1e-30 N=10 TOX=1 L=1u W=1u)
 .MODEL MWEAKMOD PMOS (VTO=-1.18 KP=0.03 IS=1e-30 N=10 TOX=1 L=1u W=1u)
 .MODEL RBKMOD RES (TC1=1.045e-3 TC2=-3.5e-7)
 .MODEL RDSMOD RES (TC1=0.92e-2 TC2=1.55e-5)
 .MODEL RSourceMOD RES (TC1=2e-3 TC2=0.5e-6)
 .MODEL RSCLMOD RES (TC1=2e-3 TC2=0)
 .MODEL RVTHRESMOD RES (TC1=-2.5e-3 TC2=0)
 .MODEL RVTEMPMOD RES (TC1=-1.55e-3 TC2=7.5e-6)
 .MODEL S1AMOD VSWITCH (RON=1e-5 ROFF=0.1 VON=5.25 VOFF=1.75)
 .MODEL S1BMOD VSWITCH (RON=1e-5 ROFF=0.1 VON=1.75 VOFF=5.25)
 .MODEL S2AMOD VSWITCH (RON=1e-5 ROFF=0.1 VON=0.5 VOFF=-0.5)
 .MODEL S2BMOD VSWITCH (RON=1e-5 ROFF=0.1 VON=-0.5 VOFF=0.5)
 .ENDS

NOTE: For further discussion of the PSPICE model consult A New PSPICE Sub-circuit for the Power MOSFET Featuring Global Temperature Options; authored by William J. Hepp and C. Frank Wheatley.

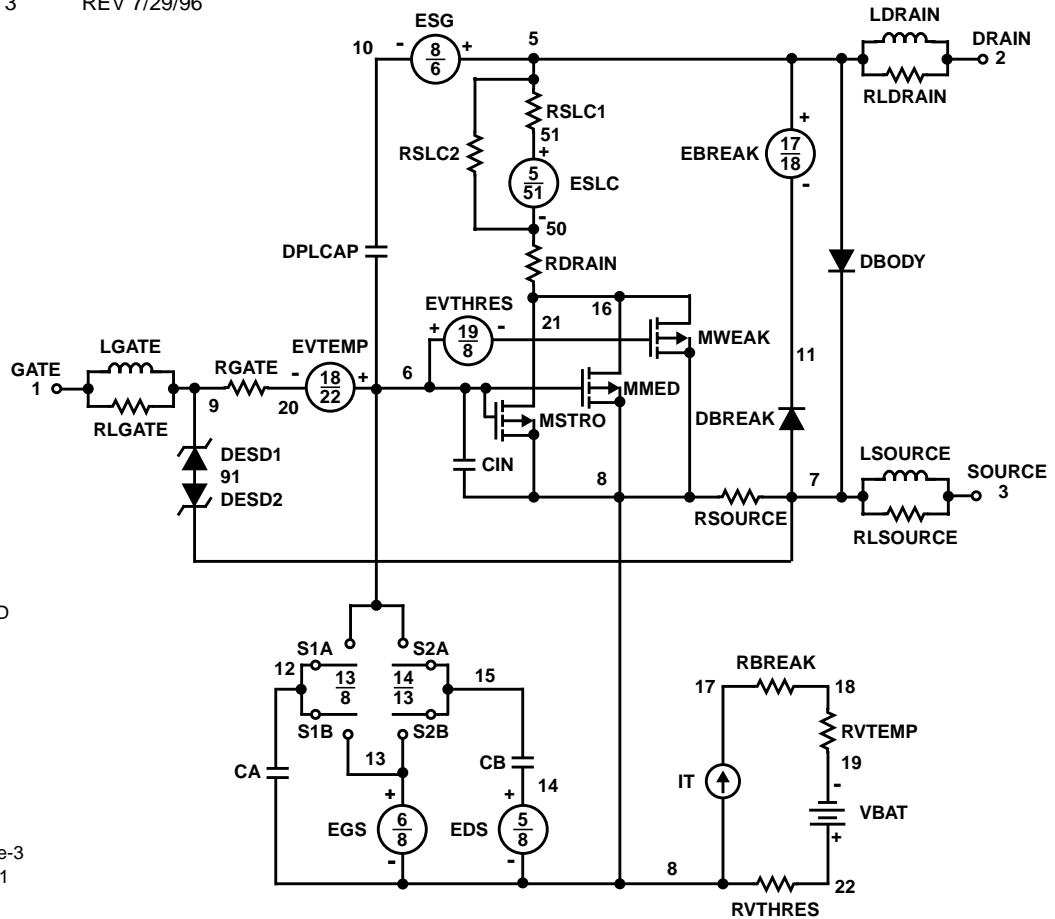

PSpice Thermal Model

REV 7/29/96

RFP8P06LE

CTHERM1 7 6 1.3e-4
 CTHERM2 6 5 4.5e-4
 CTHERM3 5 4 1e-3
 CTHERM4 4 3 2e-3
 CTHERM5 3 2 1.5e-2
 CTHERM6 2 1 0.55

RTHERM1 7 6 3.0e-2
 RTHERM2 6 5 5.0e-2
 RTHERM3 5 4 0.1
 RTHERM4 4 3 1.15
 RTHERM5 3 2 1.20
 RTHERM6 2 1 0.55

RFD8P06LE, RFD8P06LESM

CTHERM1 7 6 1.3e-4
 CTHERM2 6 5 4.5e-4
 CTHERM3 5 4 1e-3
 CTHERM4 4 3 2e-3
 CTHERM5 3 2 1.5e-2
 CTHERM6 2 1 0.12

RTHERM1 7 6 3.0e-2
 RTHERM2 6 5 5.0e-2
 RTHERM3 5 4 0.1
 RTHERM4 4 3 1.15
 RTHERM5 3 2 1.20
 RTHERM6 2 1 0.55

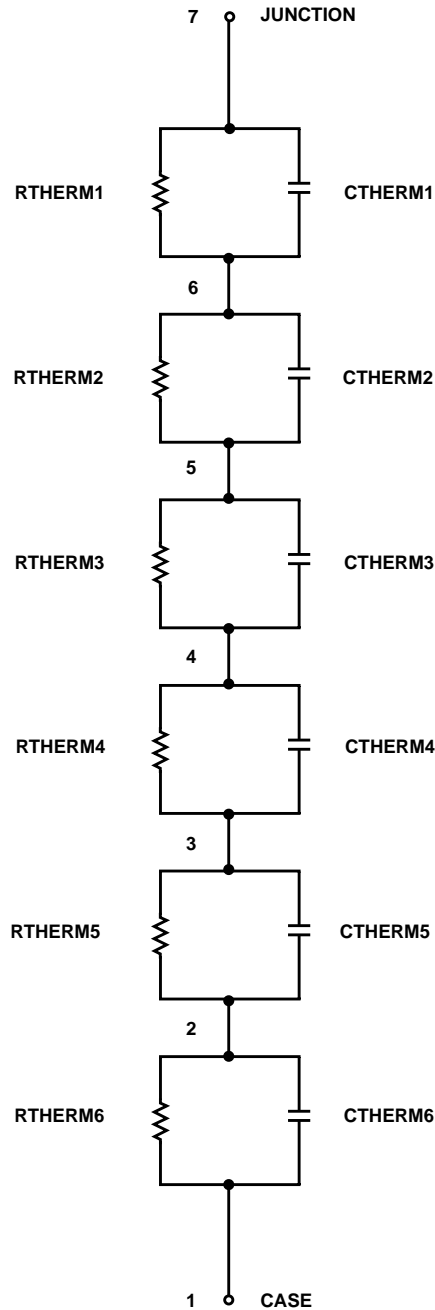

All Intersil semiconductor products are manufactured, assembled and tested under **ISO9000** quality systems certification.

Intersil semiconductor products are sold by description only. Intersil Corporation reserves the right to make changes in circuit design and/or specifications at any time without notice. Accordingly, the reader is cautioned to verify that data sheets are current before placing orders. Information furnished by Intersil is believed to be accurate and reliable. However, no responsibility is assumed by Intersil or its subsidiaries for its use; nor for any infringements of patents or other rights of third parties which may result from its use. No license is granted by implication or otherwise under any patent or patent rights of Intersil or its subsidiaries.

For information regarding Intersil Corporation and its products, see web site <http://www.intersil.com>

Sales Office Headquarters

NORTH AMERICA

Intersil Corporation
 P. O. Box 883, Mail Stop 53-204
 Melbourne, FL 32902
 TEL: (407) 724-7000
 FAX: (407) 724-7240

EUROPE

Intersil SA
 Mercure Center
 100, Rue de la Fusee
 1130 Brussels, Belgium
 TEL: (32) 2.724.2111
 FAX: (32) 2.724.22.05

ASIA

Intersil (Taiwan) Ltd.
 7F-6, No. 101 Fu Hsing North Road
 Taipei, Taiwan
 Republic of China
 TEL: (886) 2 2716 9310
 FAX: (886) 2 2715 3029