

MTD1121F

Unipolar PWM Stepper Motor Driver

Features

- Unipolar stepper motor driver
- Constant current control function (Fixed OFF Time)
- Logic supply voltage 3.3V
- TTL, CMOS compatible input
- 4-Phase input (Simultaneous ON prevention function)
- Built-in flywheel diodes
- Surface mount package with heat sink(HSOP28)

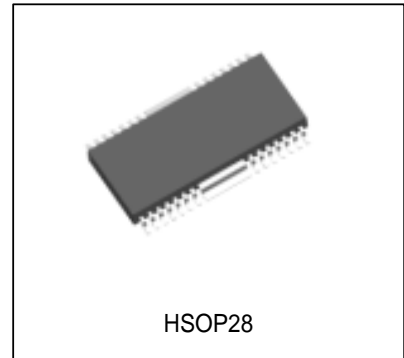

Absolute maximum ratings / Ta=25

Parameter	Symbol	Rating	Unit
Output voltage	$V_{CEO(SUS)}$	80	V
Output current	I_{OUT}	1.2	A
Logic supply	V_{CC}	0 ~ 3.6	V
Logic input	V_{LOGIC}	0 ~ V_{CC}	V
Power dissipation *	P_D	3	W
Storage temperature	Tstg	-40 ~ 150	
Maximum Junction temperature	T_J	150	

*50.8 × 50.8 × 1mm³ Glass Epoxy Board(FR4),250mm² Copper Pattern

Pin Assignment

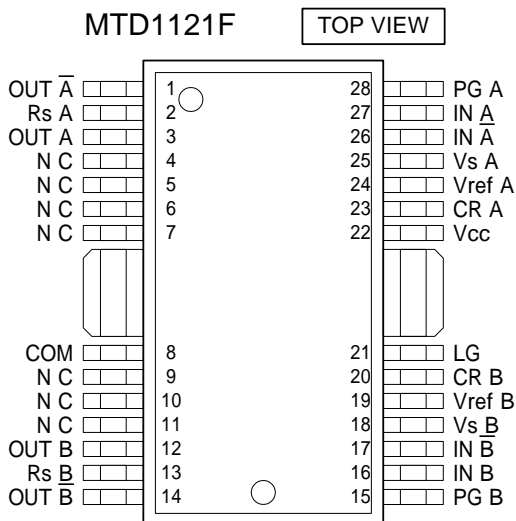

Truth table

IN A or B	IN \bar{A} or \bar{B}	OUT A or B	OUT \bar{A} or \bar{B}
L	L	OFF	OFF
L	H	OFF	ON
H	L	ON	OFF
H	H	OFF	OFF

Electrical Characteristics

Ta=25 , Vcc=3.3V unless otherwise specified

Parameter	Symbol	Condition	MIN	TYP	MAX	Unit
Output transistor saturation voltage	$V_{CE(SAT)}$	Ic=0.9A	-	1.1	1.5	V
Output transistor leak current	I_{CER}	$V_{CER}=80V$	-	-	10	μA
Flywheel diode forward drop	V_{FFW}	$I_{FFW}=0.9A$	-	1.2	1.5	V
Flywheel diode leak current	I_{RFB}	$V_{RFB}=80V$	-	-	10	μA
Flyback diode forward drop	V_{FFB}	$I_{FFB}=0.9A$	-	1.3	2	V
Flyback diode leak current	I_{RFB}	$V_{RFB}=80V$	-	-	10	μA
Logic supply current	Icc		-	30	100	mA
IN"H" input voltage	V_{INH}		2.0	-	Vcc	V
IN"L" input voltage	V_{INL}		GND	-	0.6	V
IN"H" input current	I_{INH}	$V_{IN}=3.3V$	-	-	10	μA
IN"L" input current	I_{INL}	$V_{IN}=0V$	-	-10	-50	μA
Vref input current	Iref	Vref=0V	-	-1	-50	μA
Vs input current	Isence	Vs=0V	-	-	-50	μA
Chopping frequency	f_{CHOP}		-	20	-	kHz
Oneshot off time	t_{OFF}	Rt=15k , Ct=2200pF	12	20	27	μs
Vs maximum voltage	Vs(max)		-	-	0.7	V

Recommended operation conditions

Parameter	Symbol	Recommendation	Unit
Junction temperature	Tj	-25 ~ 120	
Logic supply	Vcc	3.13 ~ 3.46	V
Load supply	Vmm	~ 27.5	V
Chopping frequency	f_{CHOP}	~ 27	kHz

Thermal resistance

Symbol	Rating	Unit
ja *	41	/W

* 50.8 × 50.8 × 1mm³ Glass Epoxy Board(FR4),250mm² Copper Pattern

Block diagram / Typical application

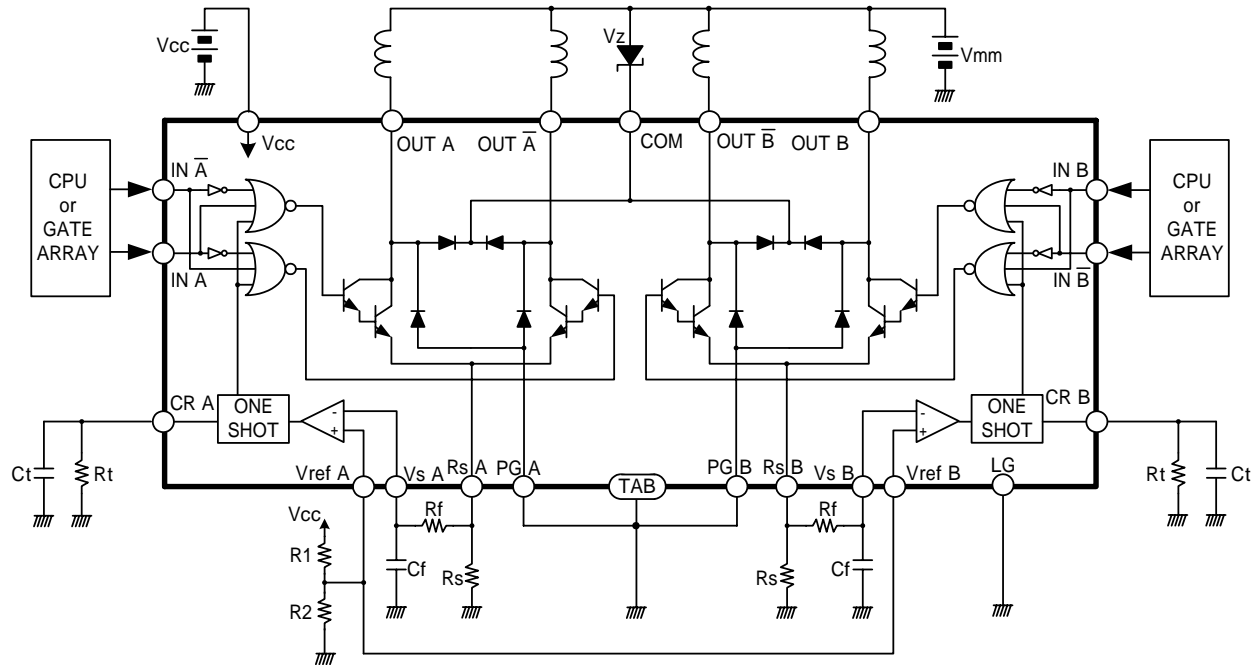

Constant chopping current level

$$I_{chop} = \frac{V_{ref}}{R_s}$$

One shot off time

$$t_{off} = 0.69 \times C_t \times R_t$$

Recommended component values

Symbol	Recommended value	Unit
R_s	0.68	
C_f	3300	pF
R_f	1.0	k
C_t	3300	pF
R_t	8.2	k
V_z	$V_{mm} \times 1.2 \sim 1.5$	V
R_1+R_2	< 10	k

Outline Drawing

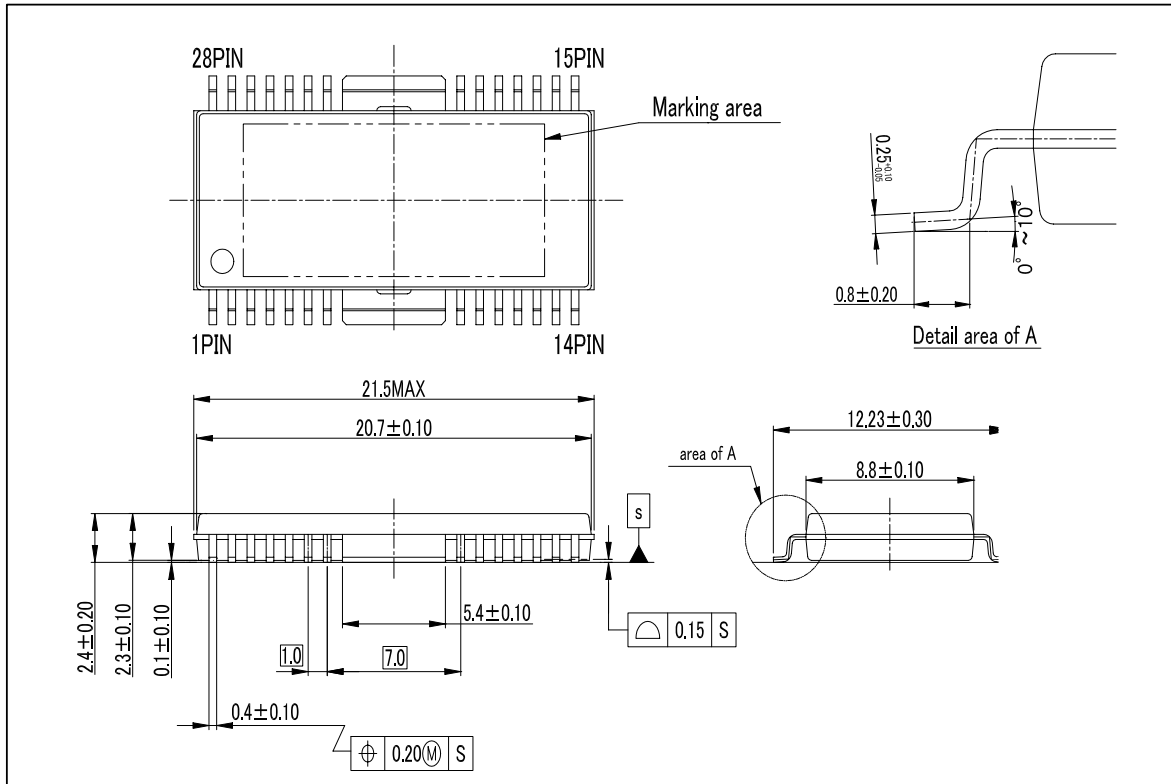

(Unit : mm)

⚠ Although we are constantly making every effort to improve the quality and reliability of our products, there nevertheless remains a certain probability that the semiconductor products may occasionally fail or malfunction. Please take careful precautions against product failures or malfunctions to avoid any injuries, fire accidents or social loss by implementing safety designs such as redundancy designs, designs for fire spread prevention, and designs for preventing malfunctions.

⚠ Our semiconductor products listed in this document are not designed or manufactured to be used in devices or systems requiring extremely high levels of quality and reliability, or the failure or malfunction of which may directly threaten human lives or cause injury. In the cases where the products are to be used in devices or systems for special applications or devices or systems for specialized applications shown below, always make sure to consult us in advance.

Special Applications

Transportation devices (automotive, marine, etc.), communication devices for core network, traffic signal devices, fire prevention/anticrime devices, various safety devices, medical devices, etc.

Specialized Applications

Nuclear power control systems, aircraft and aerospace devices, submarine relay devices, and systems for preserving life, etc.

Even if it is not for a special or specialized application, when IC products are to be used for devices or systems that are desired to last for a long period under continuous operation, please make sure to consult our sales representative in advance.

We reserve the right to make any changes to the contents of this manual without prior notice in accordance with modifications to IC products. Details of specifications should be exchanged at the adoption of the IC products.

All information included in this manual is believed to be accurate and reliable. However, our company takes no responsibility for any injury or damage incurred when using the IC products as described in this manual. Neither do we take any responsibility for issues arising from infringement of patent or other rights caused by using this manual.

The provision of this manual does not guarantee the right to use any third party's patent or other rights, or grant permission to use the patent or other rights of our company.

No part of this manual may be reproduced or copied without the specific written consent of Shindengen Electric Mfg. Co., Ltd.