

Low Phase Noise CMOS XO (96MHz to 200MHz)

FEATURES

- Low phase noise XO for the 96MHz to 200MHz range (-125 dBc at 10kHz offset).
- CMOS output.
- 12 to 25MHz crystal input.
- Integrated crystal load capacitor: no external load capacitor required.
- Low jitter (RMS): 9-12ps period jitter (1 sigma).
- 3.3V operation.
- Available in 8-Pin TSSOP or SOIC.

PIN CONFIGURATION

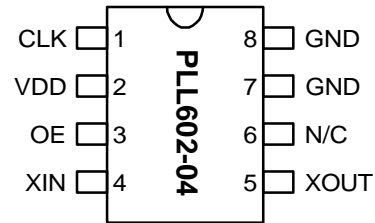

DESCRIPTIONS

The PLL602-04 is a low cost, high performance and low phase noise XO, providing less than -125 dBc at 10kHz offset in the 96MHz to 200MHz operating range. The very low jitter (9 to 12 ps RMS period jitter) makes this chip ideal for 155.52MHz SONET and SDH applications, and for 125MHz and 106.25MHz applications. Input crystal can range from 12 to 25MHz (fundamental resonant mode).

OUTPUT RANGE

MULTIPLIERS	FREQUENCY RANGE	OUTPUT BUFFER
x8	96 - 200MHz	CMOS

BLOCK DIAGRAM

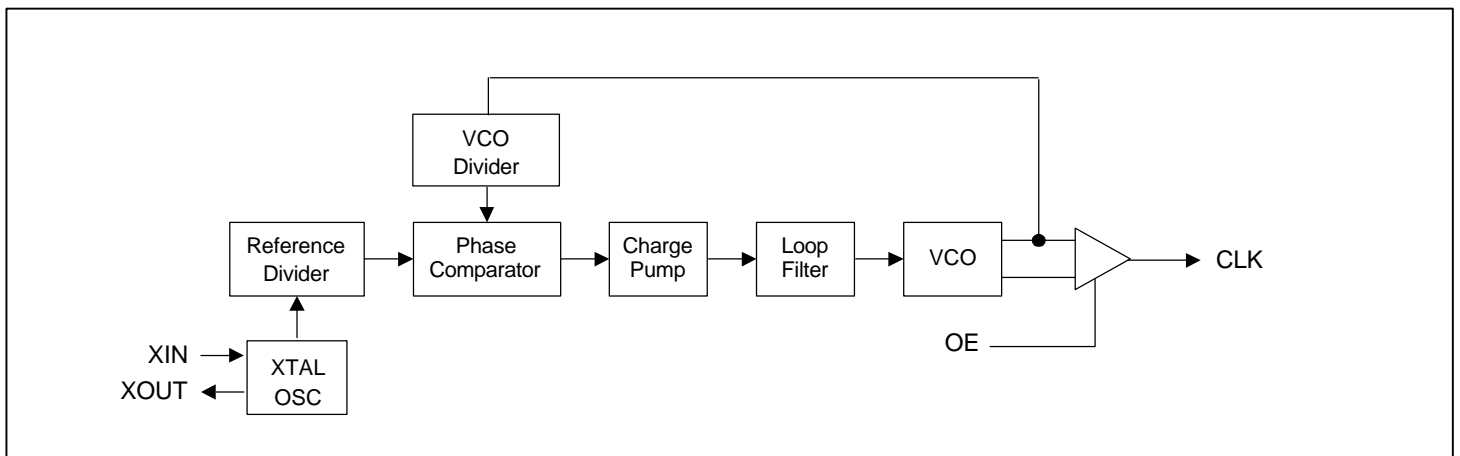

Low Phase Noise CMOS XO (96MHz to 200MHz)

PIN DESCRIPTIONS

Name	Number	Type	Description
CLK	1	O	Output clock pin.
VDD	2	P	+3.3V VDD power supply pin.
OE	3	I	Output enable input pin. Disables (tri-state) output when low. Internal pull-up enables output by default if pin is not connected to low.
XIN	4	I	Crystal input pin.
XOUT	5	I	Crystal output pin.
N/C	6	-	Not connected.
GND	7, 8	P	Ground pin.

ELECTRICAL SPECIFICATIONS

1. Absolute Maximum Ratings

PARAMETERS	SYMBOL	MIN.	MAX.	UNITS
Supply Voltage Range	V _{CC}	-0.5	7	V
Input Voltage Range	V _I	-0.5	V _{CC} +0.5	V
Output Voltage Range	V _O	-0.5	V _{CC} +0.5	V
Soldering Temperature			260	°C
Storage Temperature	T _S	-65	150	°C
Ambient Operating Temperature		-10	85	°C

Exposure of the device under conditions beyond the limits specified by Maximum Ratings for extended periods may cause permanent damage to the device and affect product reliability. These conditions represent a stress rating only, and functional operations of the device at these or any other conditions above the operational limits noted in this specification is not implied.

2. AC Specification

PARAMETERS	CONDITIONS	MIN.	TYP.	MAX.	UNITS
Input Frequency		12		25	MHz
Output Frequency		96		200	MHz
Output Rise Time	0.8V to 2.0V with 10pF load			1.5	ns
Output Fall Time	2.0V to 0.8V with 10pF load			1.5	ns
Duty Cycle	At VDD/2	45	50	55	%

Low Phase Noise CMOS XO (96MHz to 200MHz)

3. Jitter and Phase Noise specification

PARAMETERS	CONDITIONS	MIN.	TYP.	MAX.	UNITS
RMS Period Jitter (1 sigma – 1000 samples)	at 155MHz, with capacitive decoupling between VDD and GND.		12		ps
Phase Noise relative to carrier	155MHz @100Hz offset		-80		dBc/Hz
Phase Noise relative to carrier	155MHz @1kHz offset		-110		dBc/Hz
Phase Noise relative to carrier	155MHz @10kHz offset		-125		dBc/Hz
Phase Noise relative to carrier	155MHz @100kHz offset		-120		dBc/Hz
Phase Noise relative to carrier	155MHz @1MHz offset		-125		dBc/Hz

4. DC Specification

PARAMETERS	SYMBOL	CONDITIONS	MIN.	TYP.	MAX.	UNITS
Supply Current, Dynamic, with Loaded Outputs	I_{DD}	$F_{XIN} = 12 - 25\text{MHz}$ Output load of 10pF		10		mA
Operating Voltage	V_{DD}		3.13		3.47	V
Output High Voltage	V_{OH}	$I_{OH} = -12\text{mA}$	2.4			V
Output Low Voltage	V_{OL}	$I_{LO} = 12\text{mA}$			0.4	V
Output High Voltage at CMOS level	V_{OHC}	$I_{OH} = -4\text{mA}$	$V_{DD} - 0.4$			V
Output drive current		At TTL level (High drive)	36	51		mA
		At TTL level (Low drive)	12	17		mA
Short Circuit Current				± 50		mA
ESD Protection		Human Body Model, all pads except XT and XTB	3000			V
		Human Body Model, XT and XTB pads	2000			

5. Crystal Specifications

PARAMETERS	SYMBOL	MIN.	TYP.	MAX.	UNITS
Crystal Resonator Frequency	F_{XIN}	12		25	MHz
Crystal Loading Capacitance Rating	C_L (xtal)		20		pF
Driving power			1		mW
ESR	R_s			30	Ω

Low Phase Noise CMOS XO (96MHz to 200MHz)

PACKAGE INFORMATION

8 PIN (dimensions in mm)

Symbol	Narrow SOIC		TSSOP	
	Min.	Max.	Min.	Max.
A	1.47	1.73	-	1.20
A1	0.10	0.25	0.05	0.15
B	0.33	0.51	0.19	0.30
C	0.19	0.25	0.09	0.20
D	4.80	4.95	2.90	3.10
E	3.80	4.00	4.30	4.50
H	5.80	6.20	6.20	6.60
L	0.38	1.27	0.45	0.75
e	1.27 BSC		0.65 BSC	

ORDERING INFORMATION

For part ordering, please contact our Sales Department:
 47745 Fremont Blvd., Fremont, CA 94538, USA
 Tel: (510) 492-0990 Fax: (510) 492-0991

PART NUMBER

The order number for this device is a combination of the following:
 Device number, Package type and Operating temperature range

PLL602-04 X C

PART NUMBER _____

TEMPERATURE
 C=COMMERCIAL
 M=MILITARY
 I=INDUSTRIAL

PACKAGE TYPE
 S=SOIC, O=TSSOP

PhaseLink Corporation, reserves the right to make changes in its products or specifications, or both at any time without notice. The information furnished by PhaseLink is believed to be accurate and reliable. However, PhaseLink makes no guarantee or warranty concerning the accuracy of said information and shall not be responsible for any loss or damage of whatever nature resulting from the use of, or reliance upon this product.

LIFE SUPPORT POLICY: PhaseLink's products are not authorized for use as critical components in life support devices or systems without the express written approval of the President of PhaseLink Corporation.