

THIS COPY IS PROVIDED ON A RESTRICTED BASIS AND IS NOT TO BE USED IN ANY WAY DETRIMENTAL TO THE INTERESTS OF PANDUIT CORP.

PANDUIT PART NUMBER	WIRE SIZE	DIMENSIONS in.			
		A $\pm .03$	B DIA. $\pm .01$	C $\pm .003$	D DIA. $\pm .01$
BS22	26-22	.47 (11.9)	.08 (2.0)	.02 (0.5)	.04 (1.0)

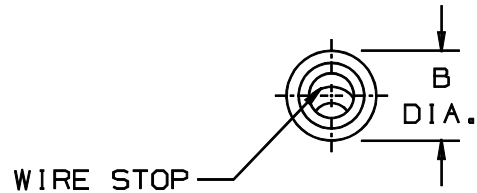

NOTES:

- UL LISTED AND CSA CERTIFIED FOR:
 - #26-22 AWG SOLID OR STRANDED COPPER WIRE
 - 302° F (150° C) MAX. TEMP. RATING
- MATERIAL:
 - .02 (0.5) THK COPPER, TIN PLATED
- PACKAGE QTY: STD. PKG.-C=100
BULK PKG.-M=1000
- DIMENSIONS IN BRACKETS ARE IN MILLIMETERS
- INSTALLATION TOOLS:
CT-100 POCKET B
- WIRE STRIP LENGTH: $9/32 \pm 1/32$ (7.1 $\pm .8$)

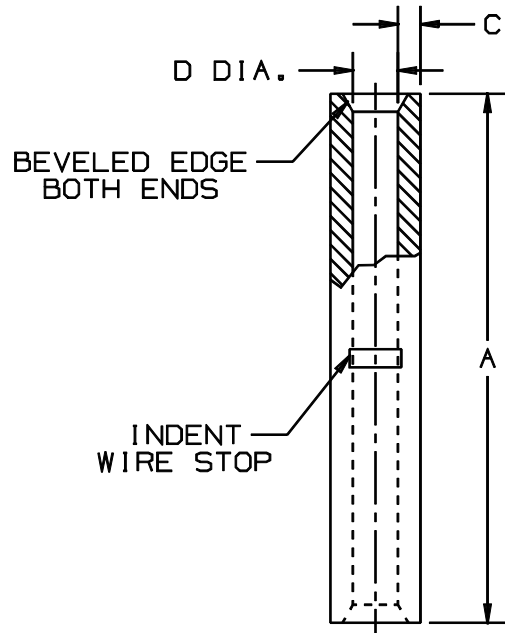

A41336_03

REV	DATE	BY	CHK	DESCRIPTION	ECN #	CUST	PM	DRAWN BY	CHK'D	SCALE	DRAWING NO.
03	1/01	RM		FILESPEC WAS N41336_PCD_02				DAW		NONE	A41336
02	12/94	TH		UPDATED NOTES AND DIMENSIONS	02709						
1	9-88	DW		REDRAWN WITH REVISIONS							

PANDUIT

CORP.

TINLEY PARK, ILLINOIS

#26-22 BARREL NON-INSULATED BUTT SPLICE