

Low Phase Noise VCXO with multipliers (for 65-130MHz Fund Xtal)

Universal Low Phase Noise IC's

FEATURES

- 65MHz to 130MHz Fundamental Mode Crystal.
- Output range: 65MHz – 800MHz (selectable 1x, 2x, 4x and 8x multipliers).
- Low Injection Power for crystal 50uW.
- Available outputs: PECL, LVDS or CMOS.
- Integrated variable capacitors.
- Supports 3.3V-Power Supply.
- Available in 16 pin (TSSOP or SOIC)

DESCRIPTIONS

PLL520-17/-18/-19 are VCXO IC specifically designed to pull high frequency fundamental crystals. Their design was optimized to tolerate higher limits of interelectrodes capacitance and bonding capacitance to improve yield. It achieves very low current into the crystal resulting in better overall stability. Its internal varicaps allow an on chip frequency pulling, controlled by the VCON input.

BLOCK DIAGRAM

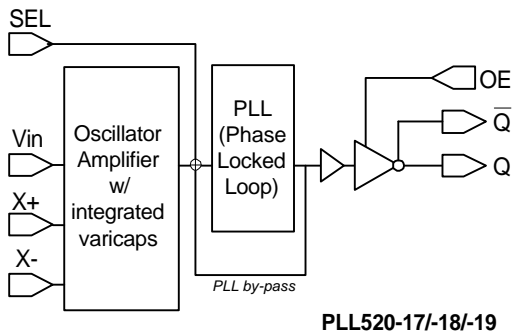

PIN CONFIGURATION

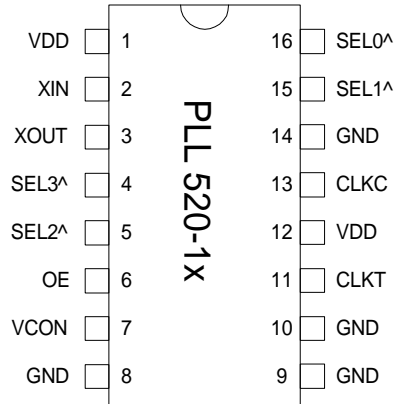

^: Internal pull-up

OUTPUT ENABLE LOGICAL LEVELS

Part #	OE	State
PLL520-18	0 (Default)	Output enabled
	1	Tri-state
PLL520-17 PLL520-19	0	Tri-state
	1 (Default)	Output enabled

OE input: Logical states defined by PECL levels for PLL520-18
Logical states defined by CMOS levels for PLL520-17/-19

Low Phase Noise VCXO with multipliers (for 65-130MHz Fund Xtal)

Universal Low Phase Noise IC's

PIN DESCRIPTIONS

Name	Number	Type	Description
XIN	2	I	Crystal in connector.
XOUT	3	I	Crystal out connector.
OE	6	I	Output enable pin.
VCON	7	I	Frequency control input (0.3V to 3.0V)
GND	8,9, 10, 14	P	GND.
CLKT	11	O	True output PECL (PLL520-18) or LVDS (PLL520-19) (N/C for PLL520-17)
CLKC	13	O	Complementary output PECL (PLL520-18) or LVDS (PLL520-19) (CMOS out for PLL520-17).
SEL	4,5,15,16	I	Multiplier selector pins. These pins have an internal pull-up that will default SEL to '1' when not connected to GND.
VDD	1, 12	P	+3.3V VDD.

FREQUENCY SELECTION TABLE

Pin #4 SEL3	Pin #5 SEL2	Pin #15 SEL1	Pin #16 SELO	Selected Multiplier
0	0	1	1	Fin x 8
1	0	1	1	Fin x 4
1	1	1	0	Fin x 2
1	1	1	1	No multiplication

All pins have internal pull-ups (default value is 1). Connect to GND to set to 0.

Low Phase Noise VCXO with multipliers (for 65-130MHz Fund Xtal)

Universal Low Phase Noise IC's

ELECTRICAL SPECIFICATIONS
1. Absolute Maximum Ratings

PARAMETERS	SYMBOL	MIN.	MAX.	UNITS
Supply Voltage	V_{DD}		7	V
Input Voltage, dc	V_I	$V_{SS}-0.5$	$V_{DD}+0.5$	V
Output Voltage, dc	V_O	$V_{SS}-0.5$	$V_{DD}+0.5$	V
Storage Temperature	T_S	-65	150	°C
Ambient Operating Temperature*	T_A	-40	85	°C
Junction Temperature	T_J		125	°C
Lead Temperature (soldering, 10s)			260	°C
Input Static Discharge Voltage Protection			2	kV

Exposure of the device under conditions beyond the limits specified by Maximum Ratings for extended periods may cause permanent damage to the device and affect product reliability. These conditions represent a stress rating only, and functional operations of the device at these or any other conditions above the operational limits noted in this specification is not implied.

* **Note:** Operating Temperature is guaranteed by design for all parts (COMMERCIAL and INDUSTRIAL), but tested for INDUSTRIAL grade only.

2. Crystal Specifications

PARAMETERS	SYMBOL	CONDITIONS	MIN.	MAX.	UNITS
Built-in Capacitance	CX+	65MHz to 130MHz (VDD=3.3V)		2	pF
	CX-			2	
Inter-electrode capacitance	C_0			2	
C0/C1 ratio (gamma)	γ			300	-
Oscillation Frequency	OF	Fund.	120	200	MHz

3. Voltage Control Crystal Oscillator

PARAMETERS	SYMBOL	CONDITIONS	MIN.	TYP.	MAX.	UNITS
VCXO Stabilization Time *	$T_{VCXOSTB}$	From power valid		10		ms
VCXO Tuning Range		XTAL $C_0/C_1 < 300$	200*			ppm
CLK output pullability		$0V \leq VCON \leq 3.3V$, at room temp.		$\pm 100^*$		ppm
On-chip Varicaps control range		$VCON = 0$ to 3.3V		4 – 18*		pF
Linearity				5*	10*	%
VCXO Tuning Characteristic				65		ppm/V
VCON input impedance				60		k Ω
VCON modulation BW		$0V \leq VCON \leq 3.3V$, -3dB	25			kHz

Note: Parameters denoted with an asterisk (*) represent nominal characterization data and are not production tested to any specific limits.

Low Phase Noise VCXO with multipliers (for 65-130MHz Fund Xtal)

Universal Low Phase Noise IC's

4. General Electrical Specifications

PARAMETERS	SYMBOL	CONDITIONS	MIN.	TYP.	MAX.	UNITS
Supply Current (Loaded Outputs)	I _{DD}	PECL/LVDS/CMOS			100/80/40	mA
Operating Voltage	V _{DD}		3.13		3.47	V
Output Clock Duty Cycle		@ 1.4V (CMOS) @ 1.25V (LVDS) @ V _{dd} - 1.3V (PECL)	45 45 45	50 50 50	55 55 55	%
Short Circuit Current				±50		mA

5. Jitter specifications

PARAMETERS	CONDITIONS	MIN.	TYP.	MAX.	UNITS
Period jitter RMS	77.76MHz		3.5*		ps
	155.52MHz		4*		
	622.08MHz		5*		
Period jitter peak-to-peak	77.76MHz		24*		ps
	155.52MHz		29*		
	622.08MHz		32*		
Integrated jitter RMS	Integrated 12 kHz to 20 MHz at 77.76MHz		0.5*		ps
	Integrated 12 kHz to 20 MHz at 155.52MHz		1.5*		
	Integrated 12 kHz to 20 MHz at 622.08MHz		1.5*		

*: To be measured

6. Phase noise specifications

PARAMETERS	FREQUENCY	@10Hz	@100Hz	@1kHz	@10kHz	@100kHz	UNITS
Phase Noise relative to carrier	77.76MHz	-75	-95	-125	-145	-155	dBc/Hz
	155.52MHz	-75	-95	-120	-125	-123	
	622.08MHz	-75	-95	-115	-118	-115	

Note: Phase Noise measured at VCON = 0V

Low Phase Noise VCXO with multipliers (for 65-130MHz Fund Xtal)

Universal Low Phase Noise IC's

7. CMOS Output Electrical Specifications

PARAMETERS	SYMBOL	CONDITIONS	MIN.	TYP.	MAX.	UNITS
Output High Voltage	V_{OH}	$I_{OH} = -12\text{mA}$ (Standard drive)	2.4			V
Output Low Voltage	V_{OL}	$I_{LO} = 12\text{mA}$ (Standard drive)			0.4	V
Output High Voltage at CMOS level	V_{OHC}	$I_{OH} = -4\text{mA}$ (Standard drive)	$V_{DD} - 0.4$			V
Output drive current		At TTL level (Standard drive)	12	17		mA

8. CMOS Switching Characteristics

PARAMETERS	SYMBOL	CONDITIONS	MIN.	TYP.	MAX.	UNITS
Output Clock Rise/Fall Time (Standard Drive)		0.8V ~ 2.0V with 10 pF load		1.15		ns
		0.3V ~ 3.0V with 15 pF load		3.7		

Low Phase Noise VCXO with multipliers (for 65-130MHz Fund Xtal)

Universal Low Phase Noise IC's

9. LVDS Electrical Characteristics

PARAMETERS	SYMBOL	CONDITIONS	MIN.	TYP.	MAX.	UNITS
Output Differential Voltage	V_{OD}	$R_L = 100 \Omega$ (see figure)	247	355	454	mV
V_{DD} Magnitude Change	ΔV_{OD}		-50		50	mV
Output High Voltage	V_{OH}			1.4	1.6	V
Output Low Voltage	V_{OL}		0.9	1.1		V
Offset Voltage	V_{OS}		1.125	1.2	1.375	V
Offset Magnitude Change	ΔV_{OS}		0	3	25	mV
Power-off Leakage	I_{OXD}	$V_{out} = V_{DD}$ or GND $V_{DD} = 0V$		± 1	± 10	μA
Output Short Circuit Current	I_{OSD}			-5.7	-8	mA

10. LVDS Switching Characteristics

PARAMETERS	SYMBOL	CONDITIONS	MIN.	TYP.	MAX.	UNITS
Differential Clock Rise Time	t_r	$R_L = 100 \Omega$ $C_L = 10 \text{ pF}$ (see figure)	0.2	0.7	1.0	ns
Differential Clock Fall Time	t_f		0.2	0.7	1.0	ns

LVDS Levels Test Circuit

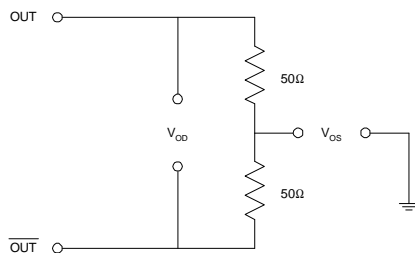

LVDS Switching Test Circuit

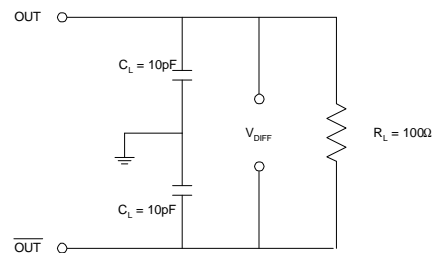

LVDS Transition Time Waveform

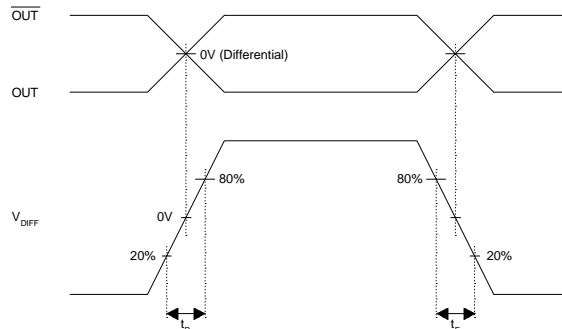

Low Phase Noise VCXO with multipliers (for 65-130MHz Fund Xtal)

Universal Low Phase Noise IC's

11. PECL Electrical Characteristics

PARAMETERS	SYMBOL	CONDITIONS	MIN.	MAX.	UNITS
Output High Voltage	V_{OH}	$R_L = 50 \Omega$ to $(V_{DD} - 2V)$ (see figure)	$V_{DD} - 1.025$		V
Output Low Voltage	V_{OL}			$V_{DD} - 1.620$	V

12. PECL Switching Characteristics

PARAMETERS	SYMBOL	CONDITIONS	MIN.	TYP.	MAX.	UNITS
Clock Rise Time	t_r	@20/80% - PECL		0.6	1.5	ns
Clock Fall Time	t_f	@80/20% - PECL		0.5	1.5	ns

PECL Levels Test Circuit

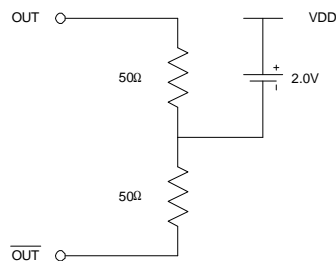

PECL Output Skew

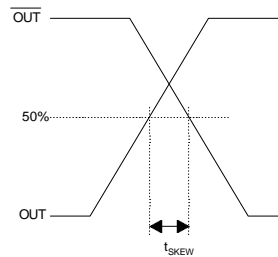

PECL Transition Time Waveform

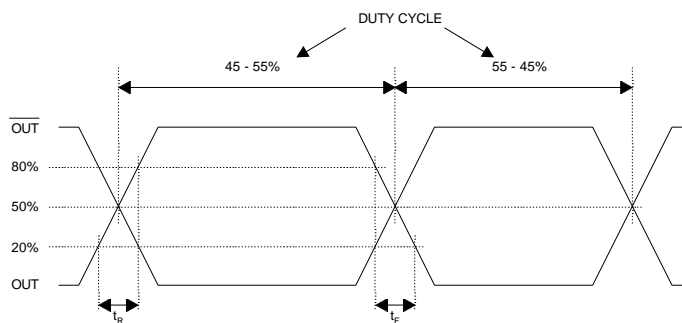

Low Phase Noise VCXO with multipliers (for 65-130MHz Fund Xtal)

Universal Low Phase Noise IC's

PACKAGE INFORMATION

16 PIN Narrow SOIC, TSSOP (mm)

Symbol	SOIC		TSSOP	
	Min.	Max.	Min.	Max.
A	1.35	1.75	-	1.20
A1	0.10	0.25	0.05	0.15
B	0.33	0.51	0.19	0.30
C	0.19	0.25	0.09	0.20
D	9.80	10.00	4.90	5.10
E	3.80	4.00	4.30	4.50
H	5.80	6.20	6.40 BSC	
L	0.40	1.27	0.45	0.75
e	1.27 BSC		0.65 BSC	

ORDERING INFORMATION

For part ordering, please contact our Sales Department:
 47745 Fremont Blvd., Fremont, CA 94538, USA
 Tel: (510) 492-0990 Fax: (510) 492-0991

PART NUMBER

The order number for this device is a combination of the following:
 Device number, Package type and Operating temperature range

PLL520-1x O C

PART NUMBER ————

TEMPERATURE
 C=COMMERCIAL
 M=MILITARY
 I=INDUSTRIAL

PACKAGE TYPE
 O=TSSOP S=SOIC

PhaseLink Corporation, reserves the right to make changes in its products or specifications, or both at any time without notice. The information furnished by Phaselink is believed to be accurate and reliable. However, PhaseLink makes no guarantee or warranty concerning the accuracy of said information and shall not be responsible for any loss or damage of whatever nature resulting from the use of, or reliance upon this product.

LIFE SUPPORT POLICY: PhaseLink's products are not authorized for use as critical components in life support devices or systems without the express written approval of the President of PhaseLink Corporation.