

Low Phase Noise VCXO with multipliers (for 65-130MHz Fund Xtal)

FEATURES

- 65MHz to 130MHz Fundamental Mode Crystal.
- Output range: 65MHz – 800MHz (selectable 1x, 2x, 4x and 8x multipliers).
- Low Injection Power for crystal 50uW.
- Available outputs: PECL, LVDS or CMOS.
- Integrated variable capacitors.
- Supports 3.3V-Power Supply.
- Available in die form.
- Thickness 10 mil.

DESCRIPTIONS

PLL520-10 is a VCXO IC specifically designed to pull frequency fundamental crystals from 65MHz to 130MHz, with an integrated Phase Locked Loop for selectable 1x (no PLL), 2x, 4x or 8x multipliers. Its design was optimized to tolerate higher limits of interelectrodes capacitance and bonding capacitance to improve yield. It achieves very low current into the crystal resulting in better overall stability. Its internal varicaps allow an on chip frequency pulling, controlled by the VCON input.

BLOCK DIAGRAM

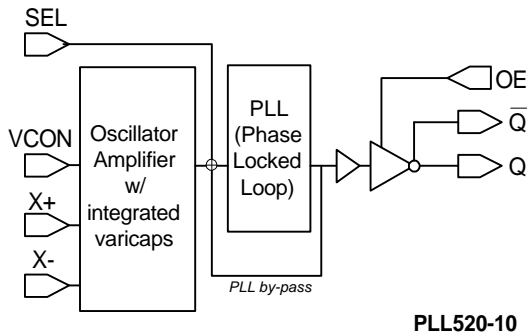

DIE CONFIGURATION

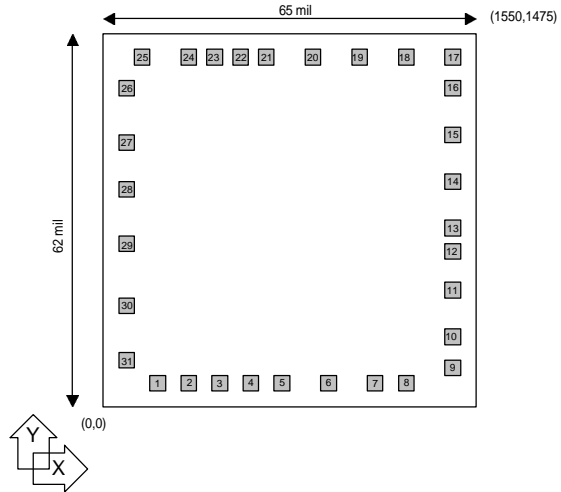

DIE SPECIFICATIONS

Name	Value
Size	62 x 65 mil
Reverse side	GND
Pad dimensions	80 micron x 80 micron
Thickness	10 mil

OUTPUT SELECTION AND ENABLE

Pad #18 OUTSEL1	Pad #25 OUTSEL0	Selected Output
0	0	High Drive CMOS
0	1	Standard CMOS
1	0	LVDS
1	1	PECL (default)

OE_SELECT (Pad #9)	OE_CTRL (Pad #30)	State
0	0	Tri-state
	1 (Default)	Output enabled
1 (Default)	0 (Default)	Output enabled
	1	Tri-state

Pad #9: Bond to GND to set to "0", bond to VDD to set to "1"
 Pad #30: Logical states defined by PECL levels if OE_SELECT (pad #9) is "1"
 Logical states defined by CMOS levels if OE_SELECT is "0"

Low Phase Noise VCXO with multipliers (for 65-130MHz Fund Xtal)
FREQUENCY SELECTION TABLE

Pad #28 SEL3	Pad #29 SEL2	Pad #19 SEL1	Pad #20 SEL0	Selected Multiplier
0	0	1	1	Fin x 8
1	0	1	1	Fin x 4
1	1	1	0	Fin x 2
1	1	1	1	No multiplication (no PLL)

All pads have internal pull-ups (default value is 1). Bond to GND to set to 0.

ELECTRICAL SPECIFICATIONS
1. Absolute Maximum Ratings

PARAMETERS	SYMBOL	MIN.	MAX.	UNITS
Supply Voltage	V_{DD}		7	V
Input Voltage, dc	V_I	$V_{SS}-0.5$	$V_{DD}+0.5$	V
Output Voltage, dc	V_O	$V_{SS}-0.5$	$V_{DD}+0.5$	V
Storage Temperature	T_S	-65	150	°C
Ambient Operating Temperature*	T_A	-40	85	°C
Junction Temperature	T_J		125	°C
Lead Temperature (soldering, 10s)			260	°C
Input Static Discharge Voltage Protection			2	kV

Exposure of the device under conditions beyond the limits specified by Maximum Ratings for extended periods may cause permanent damage to the device and affect product reliability. These conditions represent a stress rating only, and functional operations of the device at these or any other conditions above the operational limits noted in this specification is not implied.

* **Note:** Operating Temperature is guaranteed by design for all parts (COMMERCIAL and INDUSTRIAL), but tested for INDUSTRIAL grade only.

2. Crystal Specifications

PARAMETERS	SYMBOL	CONDITIONS	MIN.	TYP.	MAX.	UNITS
Built-in Capacitance	CX+	65MHz to 130 MHz (VDD=3.3V)			2	pF
	CX-				2	
Inter-electrode capacitance	C_0			2.6		
C0/C1 ratio (gamma)	γ				350	-
Oscillation Frequency	OF	Fund.	65		130	MHz

Low Phase Noise VCXO with multipliers (for 65-130MHz Fund Xtal)

3. Voltage Control Crystal Oscillator

PARAMETERS	SYMBOL	CONDITIONS	MIN.	TYP.	MAX.	UNITS
VCXO Stabilization Time *	$T_{VCXOSTB}$	From power valid		10		ms
VCXO Tuning Range		XTAL $C_0/C_1 < 350$	200*			ppm
CLK output pullability		$0V \leq VCON \leq 3.3V$, at room temp.		$\pm 100^*$		ppm
On-chip Varicaps control range		$VCON = 0$ to 3.3V		4 – 18*		pF
Linearity				5*	10*	%
VCXO Tuning Characteristic				65		ppm/V
VCON input impedance				60		k Ω
VCON modulation BW		$0V \leq VCON \leq 3.3V$, -3dB	25			kHz

Note: Parameters denoted with an asterisk (*) represent nominal characterization data and are not production tested to any specific limits.

4. General Electrical Specifications

PARAMETERS	SYMBOL	CONDITIONS	MIN.	TYP.	MAX.	UNITS
Supply Current (Loaded Outputs)	I_{DD}	PECL/LVDS/CMOS			100/80/40	mA
Operating Voltage	V_{DD}		3.13		3.47	V
Output Clock Duty Cycle		@ 1.4V (CMOS) @ 1.25V (LVDS) @ $V_{DD} - 1.3V$ (PECL)	45 45 45	50 50 50	55 55 55	%
Short Circuit Current				± 50		mA

Low Phase Noise VCXO with multipliers (for 65-130MHz Fund Xtal)

5. Jitter specifications

PARAMETERS	CONDITIONS	MIN.	TYP.	MAX.	UNITS
Period jitter RMS	77.76MHz		3.5*		ps
	155.52MHz		4*		
	622.08MHz		5*		
Period jitter peak-to-peak	77.76MHz		24*		ps
	155.52MHz		29*		
	622.08MHz		32*		
Integrated jitter RMS	Integrated 12 kHz to 20 MHz at 77.76MHz		0.5*		ps
	Integrated 12 kHz to 20 MHz at 155.52MHz		1.5*		
	Integrated 12 kHz to 20 MHz at 622.08MHz		1.5*		

*: To be measured

6. Phase noise specifications

PARAMETERS	FREQUENCY	@ 10Hz	@100Hz	@1kHz	@10kHz	@100kHz	UNITS
Phase Noise relative to carrier	77.76MHz	-75	-95	-125	-145	-155	dBc/Hz
	155.52MHz	-75	-95	-120	-125	-123	
	622.08MHz	-75	-95	-115	-118	-115	

Note: Phase Noise at VCON = 0V – to be measured

7. CMOS Output Electrical Specifications

PARAMETERS	SYMBOL	CONDITIONS	MIN.	TYP.	MAX.	UNITS
Output High Voltage	V_{OH}	$I_{OH} = -12mA$ (Standard drive)	2.4			V
Output Low Voltage	V_{OL}	$I_{LO} = 12mA$ (Standard drive)			0.4	V
Output High Voltage at CMOS level	V_{OHC}	$I_{OH} = -4mA$ (Standard drive)	$V_{DD} - 0.4$			V
Output drive current		At TTL level (High drive)	36	51		mA
		At TTL level (Standard drive)	12	17		mA

8. CMOS Switching Characteristics

PARAMETERS	SYMBOL	CONDITIONS	MIN.	TYP.	MAX.	UNITS
Output Clock Rise/Fall Time (Standard Drive)		0.8V ~ 2.0V with 10 pF load		1.15		ns
		0.3V ~ 3.0V with 15 pF load		3.7		
Output Clock Rise/Fall Time (High Drive)		0.8V ~ 2.0V with 10 pF load		0.5		
		0.3V ~ 3.0V with 15 pF load		1.5		

Low Phase Noise VCXO with multipliers (for 65-130MHz Fund Xtal)

9. LVDS Electrical Characteristics

PARAMETERS	SYMBOL	CONDITIONS	MIN.	TYP.	MAX.	UNITS
Output Differential Voltage	V_{OD}	$R_L = 100 \Omega$ (see figure)	247	355	454	mV
V_{DD} Magnitude Change	ΔV_{OD}		-50		50	mV
Output High Voltage	V_{OH}			1.4	1.6	V
Output Low Voltage	V_{OL}		0.9	1.1		V
Offset Voltage	V_{OS}		1.125	1.2	1.375	V
Offset Magnitude Change	ΔV_{OS}		0	3	25	mV
Power-off Leakage	I_{OXD}	$V_{out} = V_{DD}$ or GND $V_{DD} = 0V$		± 1	± 10	μA
Output Short Circuit Current	I_{OSD}			-5.7	-8	mA

10. LVDS Switching Characteristics

PARAMETERS	SYMBOL	CONDITIONS	MIN.	TYP.	MAX.	UNITS
Differential Clock Rise Time	t_r	$R_L = 100 \Omega$ $C_L = 10 \text{ pF}$ (see figure)	0.2	0.7	1.0	ns
Differential Clock Fall Time	t_f		0.2	0.7	1.0	ns

LVDS Levels Test Circuit

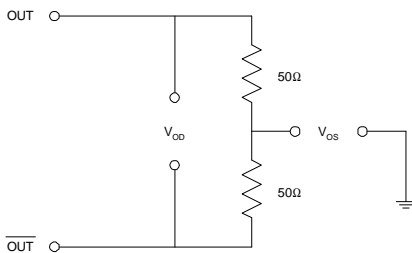

LVDS Switching Test Circuit

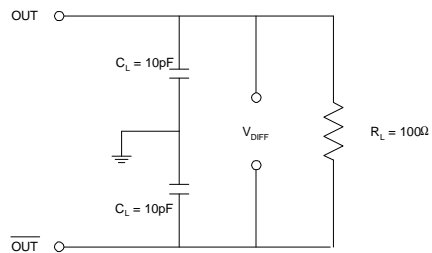

LVDS Transition Time Waveform

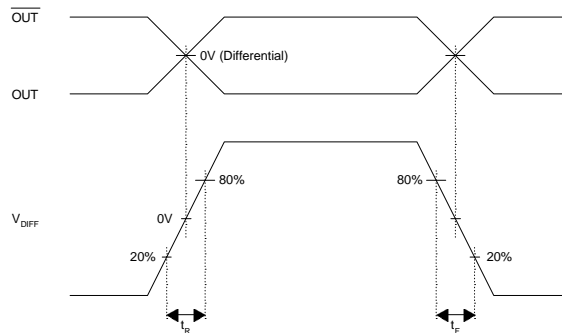

Low Phase Noise VCXO with multipliers (for 65-130MHz Fund Xtal)

11. PECL Electrical Characteristics

PARAMETERS	SYMBOL	CONDITIONS	MIN.	MAX.	UNITS
Output High Voltage	V_{OH}	$R_L = 50 \Omega$ to $(V_{DD} - 2V)$ (see figure)	$V_{DD} - 1.025$		V
Output Low Voltage	V_{OL}			$V_{DD} - 1.620$	V

12. PECL Switching Characteristics

PARAMETERS	SYMBOL	CONDITIONS	MIN.	TYP.	MAX.	UNITS
Clock Rise Time	t_r	@20/80% - PECL		0.6	1.5	ns
Clock Fall Time	t_f	@80/20% - PECL		0.5	1.5	ns

PECL Levels Test Circuit

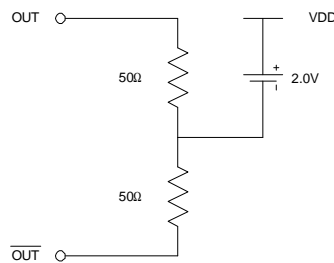

PECL Output Skew

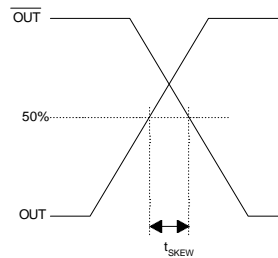

PECL Transition Time Waveform

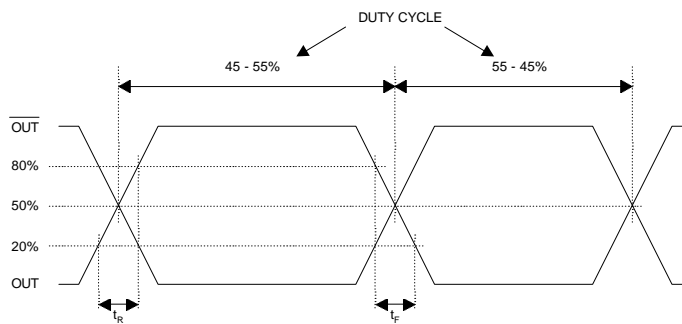

Low Phase Noise VCXO with multipliers (for 65-130MHz Fund Xtal)
PAD ASSIGNMENT

Pad #	Name	X (μm)	Y (μm)
1	GND	248	109
2	GND	361	109
3	GND	473	109
4	GND	587	109
5	GND	702	109
6	N/C	874	109
7	GND	1042	109
8	GNDBUF	1171	109
9	OE_SELECT	1400	125
10	LVDS	1400	259
11	PECL	1400	476
12	VDDBUF	1400	616
13	VDDBUF	1400	716
14	PECLB	1400	871
15	LVDSB	1400	1089
16	CMOS	1400	1227
17	GNDBUF	1389	1365
18	OUTSEL1	1232	1365
19	SEL1	1042	1365
20	SEL0	854	1365
21	VDD	659	1365
22	VDD	559	1365
23	VDD	459	1365
24	VDD	358	1365
25	OUTSEL0	194	1365
26	XIN	109	1223
27	XOUT	109	1017
28	SEL3	109	858
29	SEL2	109	646
30	OE_CTRL	109	397
31	VCON	109	181

Low Phase Noise VCXO with multipliers (for 65-130MHz Fund Xtal)

ORDERING INFORMATION

For part ordering, please contact our Sales Department:

47745 Fremont Blvd., Fremont, CA 94538, USA

Tel: (510) 492-0990 Fax: (510) 492-0991

PART NUMBER

The order number for this device is a combination of the following:

Device number, Package type and Operating temperature range

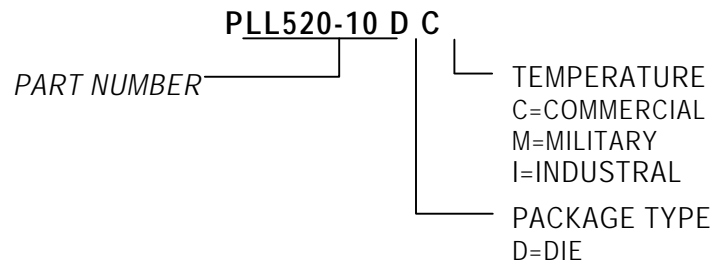

PhaseLink Corporation, reserves the right to make changes in its products or specifications, or both at any time without notice. The information furnished by Phaselink is believed to be accurate and reliable. However, PhaseLink makes no guarantee or warranty concerning the accuracy of said information and shall not be responsible for any loss or damage of whatever nature resulting from the use of, or reliance upon this product.

LIFE SUPPORT POLICY: *PhaseLink's products are not authorized for use as critical components in life support devices or systems without the express written approval of the President of PhaseLink Corporation.*