

SGM3003

Ultra Low ON-Resistance, Low Voltage, SPDT Analog Switch

GENERAL DESCRIPTION

The SGM3003 is a single, low ON-resistance, low voltage, bidirectional, single-pole/double-throw (SPDT) CMOS analog switches designed to operate from a single +1.8V to +5.5V supply. Targeted applications include battery powered equipment that benefit from low R_{ON} (0.5Ω) and fast switching speeds ($t_{ON} = 21\text{ ns}$, $t_{OFF} = 9\text{ ns}$).

The on resistance profile is very flat over the full analog signal range. This ensures excellent linearity and low distortion when switching audio signals.

SGM3003 has one normally open switch and one normally closed switch. Each switch conducts equally well in both directions when on.

SGM3003 is available in a MSOP-8 package.

APPLICATIONS

- Battery powered, Handheld, and Portable Equipments
 - Cellular/mobile Phones
 - Laptops, Notebooks, Palmtops
- Communication Systems
- Sample-and-Hold Circuits
- Audio Signal Routing
- Audio and Video Switching
- Portable Test and Measurement
- Medical Equipment

FEATURES

- Low Voltage Operation : 1.8 V to 5.5 V
- Low On-Resistance: 0.5Ω(TYP)
- Low On-Resistance Flatness
- -3 dB Bandwidth: 30 MHz
- Fast Switching Time($V_{+}=5V$)
 - t_{ON} 21 ns
 - t_{OFF} 9 ns
- Rail-to-Rail Operation
- Typical Power Consumption (<0.01 μW)
- TTL/CMOS Compatible
- Microsize Package

PIN CONFIGURATIONS (TOP VIEW)

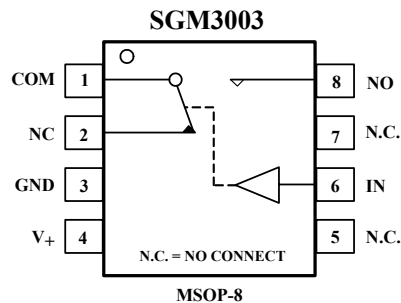

FUNCTION TABLE

LOGIC	NC	NO
0	ON	OFF
1	OFF	ON



Shengbang Microelectronics Co, Ltd
Tel: 86/451/84348461
www.sg-micro.com

REV. C

ORDERING INFORMATION

MODEL	PIN-PACKAGE	SPECIFIED TEMPERATURE RANGE	ORDERING NUMBER	PACKAGE MARKING	PACKAGE OPTION
SGM3003	MSOP-8	- 40°C to +125°C	SGM3003XMS/TR	SGM3003XMS	Tape and Reel, 3000

ABSOLUTE MAXIMUM RATINGS

V₊ to GND.....- 0.3V to +6V
 Analog, Digital voltage range(1)..... - 0.3V to V₊ + 0.3V
 Continuous Current NO, NC, or COM..... ±300mA
 Peak Current NO, NC, or COM ±500mA
 Operating Temperature Range.....- 40°C to +125°C
 Junction Temperature.....+150°C
 Storage Temperature.....- 65°C to +150°C

Package Thermal Resistance @ T_A = 25°C
 MSOP-8, θ_{JA}.....216°C/W
 Lead Temperature (soldering, 10s).....260°C
 ESD Susceptibility
 HBM.....2000V
 MM.....400V

Stresses beyond those listed under “Absolute Maximum Ratings” may cause permanent damage to the device. These are stress ratings only, and functional operation of the device at these or any other conditions beyond those indicated in the operational sections of the specifications is not implied. Exposure to absolute maximum rating conditions for extended periods may affect device reliability.

(1) Signals on NC, NO, or COM or IN exceeding V₊ will be clamped by internal diodes. Limit forward diode current to maximum current ratings.

PIN DESCRIPTION

NAME	PIN	FUNCTION
V ₊	4	Power supply
GND	3	ground
IN	6	Digital control pin to connect the COM terminal to the NO or NC terminals
COM	1	Common terminal
NO	8	Normally-open terminal
NC	2	Normally-closed terminal
N.C.	5, 7	No internal connection

Note: NO, NC and COM terminal may be an input or output.

ELECTRICAL CHARACTERISTICS

(V₊ = +5 V ± 10%, GND = 0 V, T_A = - 40°C to +125°C, unless otherwise noted. Typical values are at T_A = + 25°C.)

PARAMETER	SYMBOL	CONDITIONS	SGM3003			
			+25°C	- 40°C to +125°C	UNITS	MIN/ MAX
ANALOG SWITCH						
Analogue Signal Range	V _{NO} , V _{NC} , V _{COM}			0 V ₊	V V	MIN MAX
On-Resistance	R _{ON}	0 ≤ V _{NO} or V _{NC} ≤ V ₊ , I _{COM} = -10 mA, Test Circuit 1	0.5 0.9		Ω Ω	TYP MAX
On-Resistance Flatness	R _{FLAT(ON)}	0 ≤ V _{NO} or V _{NC} ≤ V ₊ , I _{COM} = -10 mA, Test Circuit 1	0.13 0.2		Ω Ω	TYP MAX
LEAKAGE CURRENTS						
Source OFF Leakage current	I _{NC(OFF)} , I _{NO(OFF)}	V _{NO} or V _{NC} = 4.5V/1V, V _{COM} = 1V/4.5V, V ₊ = +5.5V, Test Circuit 2	±4 ±10		nA nA	TYP MAX
Channel ON Leakage current	I _{NC(ON)} , I _{NO(ON)} , I _{COM(ON)}	V _{NO} or V _{NC} = V _{COM} = 1V or 4.5V, V ₊ = +5.5V, Test Circuit 3	±4 ±10		nA nA	TYP MAX
DIGITAL INPUTS						
Input High Voltage	V _{INH}			2.4	V	MIN
Input Low Voltage	V _{INL}			0.8	V	MAX
Input Current	I _{INL} or I _{INH}	V _{IN} = V _{INH} or V _{INL}	±0.01 ±0.1		μA μA	TYP MAX
DYNAMIC CHARACTERISTICS						
Turn-On Time	t _{ON}	V _{NO} or V _{NC} = 3V, R _L = 300Ω, C _L = 35pF, Test Circuit 4	21		ns	TYP
Turn-Off Time	t _{OFF}	V _{NO} or V _{NC} = 3V, R _L = 300Ω, C _L = 35pF, Test Circuit 4	9		ns	TYP
Charge Injection,	Q	C _L = 1.0nF, V _G = 0V, R _G = 0, Test Circuit 5	5		pC	TYP
Break-Before-Make Time Delay	t _d	V _{NO1} or V _{NC1} = V _{NO2} or V _{NC2} = 3V, R _L = 300Ω, C _L = 35pF, Test Circuit 6	10		ns	TYP
Off Isolation	O _{ISO}	R _L = 50Ω, C _L = 5pF, Test Circuit 7		f = 100KHz f = 10KHz	dB dB	TYP TYP
Total Harmonic Distortion	THD	f = 20Hz to 20KHz, V _{COM} = 3.5V _{PP} , R _L = 600Ω, C _L = 50pF	0.065		%	TYP
Bandwidth -3 dB	BW	R _L = 50Ω, C _L = 5pF, Test Circuit 8	30		MHz	TYP
Source OFF Capacitance	C _{NC(OFF)} , C _{NO(OFF)}		82		pF	TYP
Channel ON Capacitance	C _{NC(ON)} , C _{NO(ON)} , C _{COM(ON)}		380		pF	TYP
POWER REQUIREMENTS						
Power Supply Current	I ₊	V ₊ = +5.5V, V _{IN} = 0V or 5V	0.001		μA	TYP
				1	μA	MAX

Specifications subject to change without notice.

ELECTRICAL CHARACTERISTICS

(V₊ = +3 V ± 10%, GND = 0 V, T_A = - 40°C to +125°C, unless otherwise noted. Typical values are at T_A = + 25°C.)

PARAMETER	SYMBOL	CONDITIONS	SGM3003			
			+25°C	- 40°C to +125°C	UNITS	MIN/ MAX
ANALOG SWITCH						
Analogue Signal Range	V _{NO} , V _{NC} , V _{COM}			0 V ₊	V V	MIN MAX
On-Resistance	R _{ON}	0 ≤ V _{NO} or V _{NC} ≤ V ₊ , I _{COM} = -10 mA, Test Circuit 1	0.6 1.0		Ω Ω	TYP MAX
On-Resistance Flatness	R _{FLAT(ON)}	0 ≤ V _{NO} or V _{NC} ≤ V ₊ , I _{COM} = -10 mA, Test Circuit 1	0.18 0.3		Ω Ω	TYP MAX
LEAKAGE CURRENTS						
Source OFF Leakage current	I _{NC(OFF)} , I _{NO(OFF)}	V _{NO} or V _{NC} = 3V/1V, V _{COM} = 1V/3V, V ₊ = +3.3V, Test Circuit 2	±5 ±11		nA nA	TYP MAX
Channel ON Leakage current	I _{NC(ON)} , I _{NO(ON)} , I _{COM(ON)}	V _{NO} or V _{NC} = V _{COM} = 1V or 3V, V ₊ = +3.3V, Test Circuit 3	±5 ±11		nA nA	TYP MAX
DIGITAL INPUTS						
Input High Voltage	V _{INH}			2.0	V	MIN
Input Low Voltage	V _{INL}			0.4	V	MAX
Input Current	I _{INL} or I _{INH}	V _{IN} = V _{INH} or V _{INL}	±0.01 ±0.1		μA μA	TYP MAX
DYNAMIC CHARACTERISTICS						
Turn-On Time	t _{ON}	V _{NO} or V _{NC} = 2V, R _L = 300Ω, C _L = 35pF, Test Circuit 4	32		ns	TYP
Turn-Off Time	t _{OFF}	V _{NO} or V _{NC} = 2V, R _L = 300Ω, C _L = 35pF, Test Circuit 4	20		ns	TYP
Charge Injection,	Q	C _L = 1.0nF, V _G = 0V, R _G = 0, Test Circuit 5	10		pC	TYP
Break-Before-Make Time Delay	t _d	V _{NO1} or V _{NC1} = V _{NO2} or V _{NC2} = 2V, R _L = 300Ω, C _L = 35pF, Test Circuit 6	12		ns	TYP
Off Isolation	O _{ISO}	R _L = 50Ω, C _L = 5pF, Test Circuit 7		f = 100KHz f = 10KHz	dB dB	TYP TYP
Total Harmonic Distortion	THD	f = 20Hz to 20KHz, V _{COM} = 2V _{P-P} , R _L = 600Ω, C _L = 50pF	0.06		%	TYP
Bandwidth -3 dB	BW	R _L = 50Ω, C _L = 5pF, Test Circuit 8	30		MHz	TYP
Source OFF Capacitance	C _{NC(OFF)} , C _{NO(OFF)}		82		pF	TYP
Channel ON Capacitance	C _{NC(ON)} , C _{NO(ON)} , C _{COM(ON)}		380		pF	TYP
POWER REQUIREMENTS						
Power Supply Current	I ₊	V ₊ = +3.3V, V _{IN} = 0V or 3V	0.001		μA	TYP
				1	μA	MAX

Specifications subject to change without notice.

TYPICAL PERFORMANCE CHARACTERISTICS

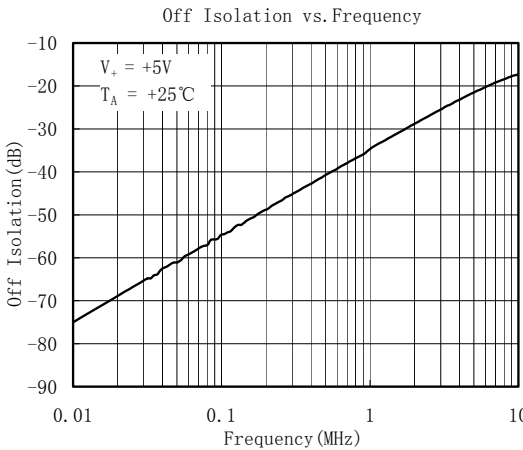
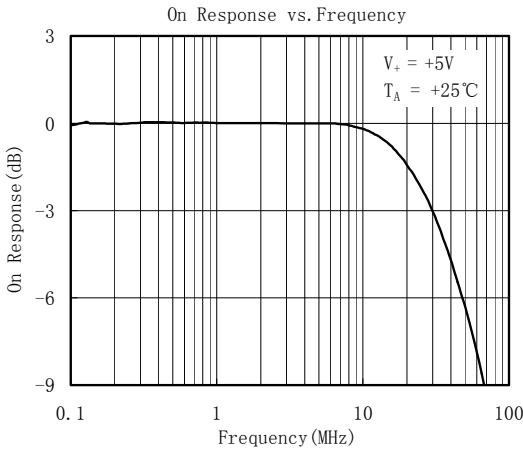

TEST CIRCUITS

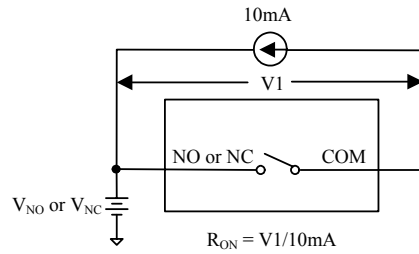

Test Circuit 1. On Resistance

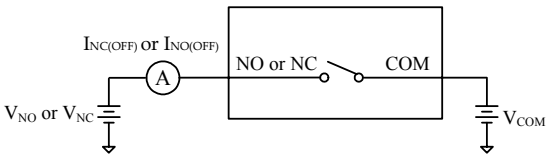

Test Circuit 2: Off Leakage

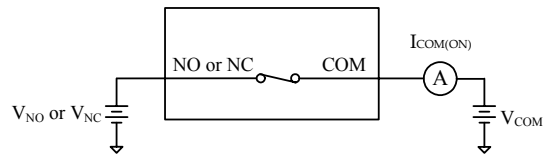

Test Circuit 3: On Leakage

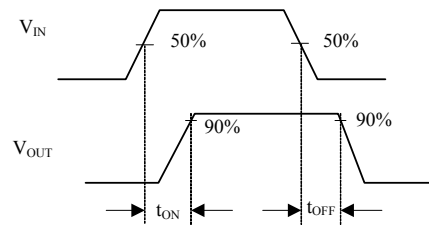
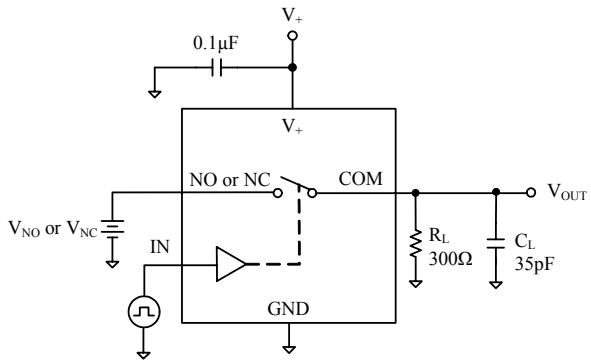

Test Circuit 4: Switching Times

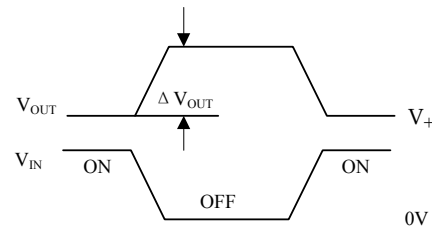
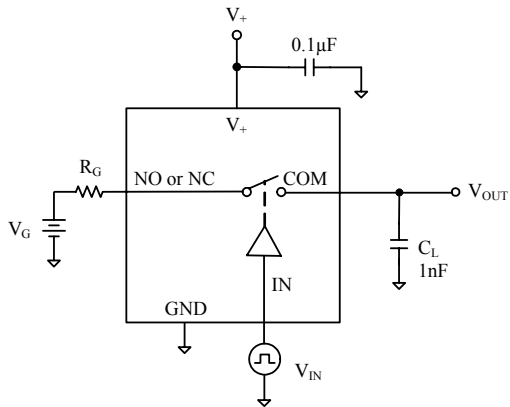

Test Circuit 5: Charge Injection

TEST CIRCUITS(Cont.)

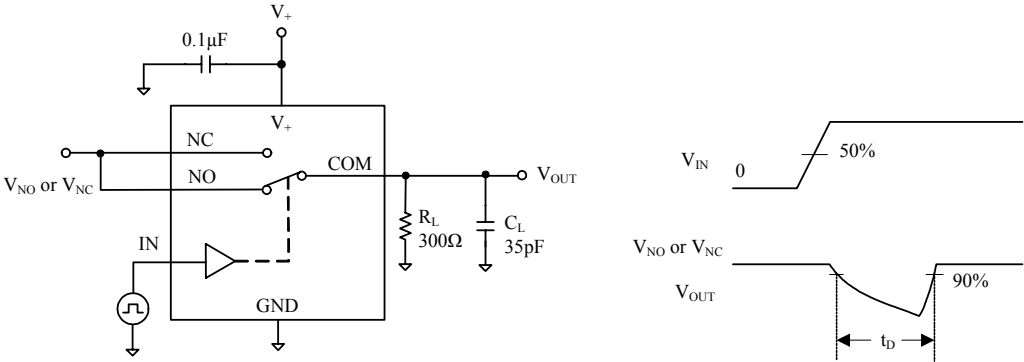

Test Circuit 6. Break-Before-Make Time Delay, t_D

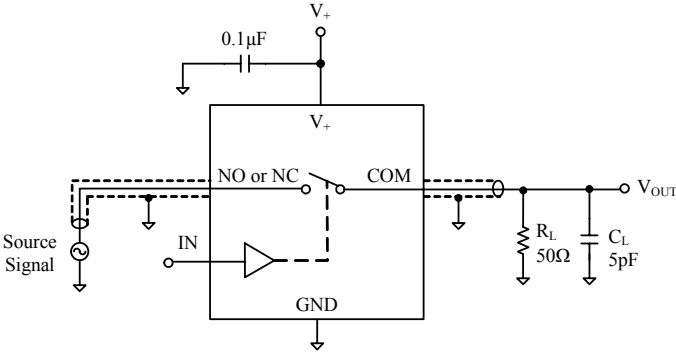

Test Circuit 7. Off Isolation

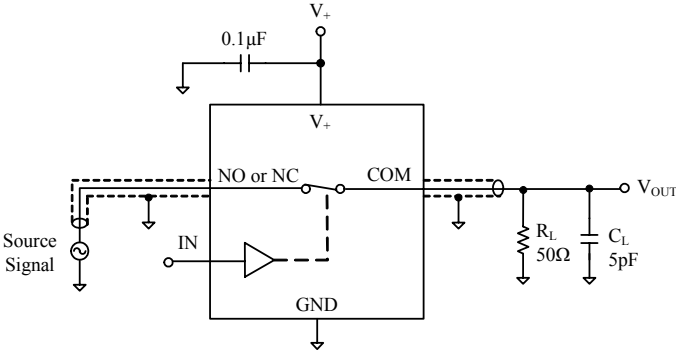

Test Circuit 8. Bandwidth

PACKAGE OUTLINE DIMENSIONS

MSOP-8

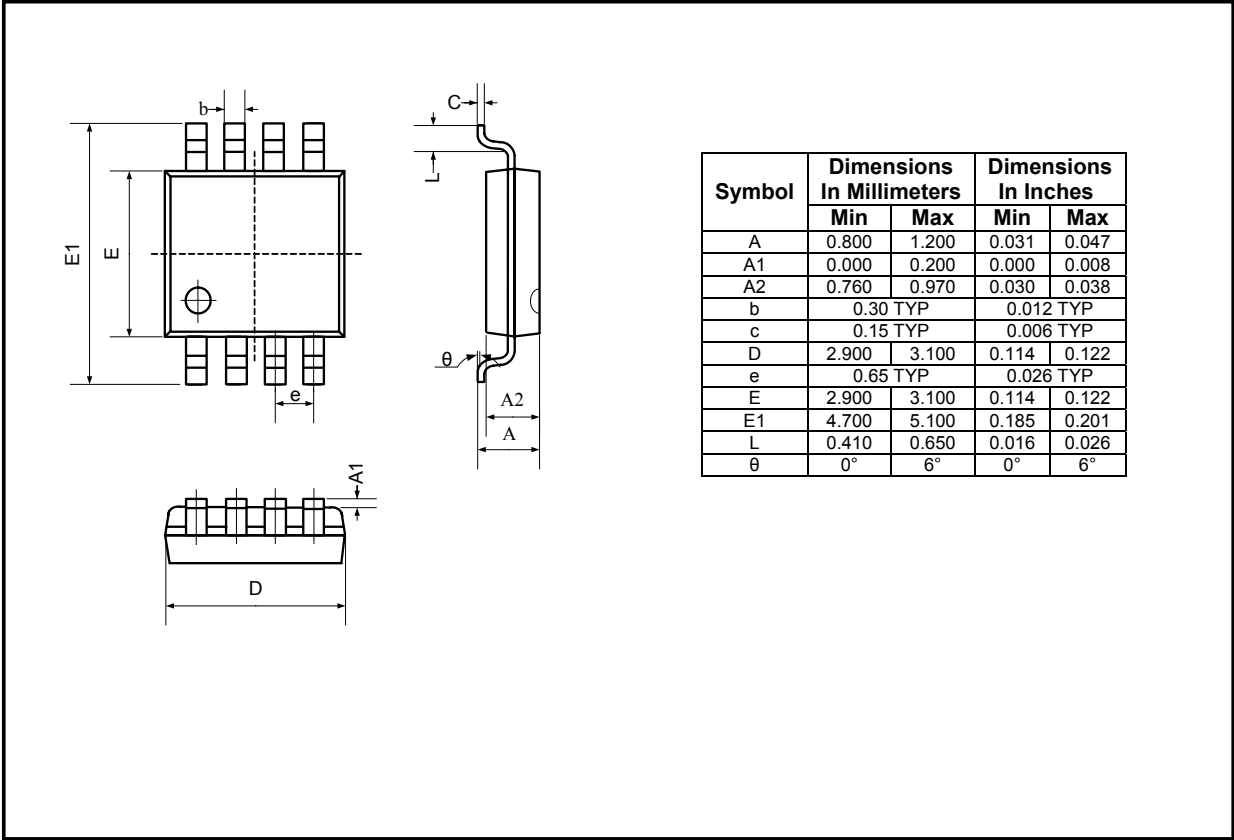

REVISION HISTORY

Location	Page
11/06— Data Sheet changed from REV.A to REV.B Changes to ABSOLUTE MAXIMUM RATINGS	2
10/07— Data Sheet changed from REV.B to REV.C Changes to TYPICAL PERFORMANCE CHARACTERISTICS	5

Shengbang Microelectronics Co, Ltd

Unit 3, ChuangYe Plaza
No.5, TaiHu Northern Street, YingBin Road Centralized Industrial Park
Harbin Development Zone
Harbin, HeiLongJiang 150078
P.R. China
Tel.: 86-451-84348461
Fax: 86-451-84308461
www.sg-micro.com