

SGM2358

1MHz, General Purpose CMOS Operational Amplifier

PRODUCT DESCRIPTION

The SGM2358 has dual rail-to-rail output voltage feedback amplifiers in one package. It takes the minimum operating supply voltage down to 3V and the maximum recommended supply voltage is 5.5 V. SGM2358 is specified over the extended -40°C to +85°C temperature range.

The amplifier in SGM2358 provides 1MHz bandwidth, Very low input bias currents of 10pA, these features enable SGM2358 to be used for integrators, photodiode amplifiers, and piezoelectric sensors. Rail-to-rail output feature is useful for designers to buffer ASIC in single-supply systems.

Applications of SGM2358 include safety monitoring, portable equipment, battery and power supply control, signal conditioning and interfacing for transducers in low power systems.

The SGM2358 comes in SO-8 package.

FEATURES

- Low Cost
- Rail-to-Rail Output
1.7mV Typical V_{os}
- Unity Gain Stable
- Gain Bandwidth Product: 1MHz
- Very Low Input Bias Currents: 10pA
- Input Common-Mode Voltage Range Includes Ground
- Operates from 3 V to 5.5 V
- Small Packaging: SO-8

APPLICATIONS

ASIC Input or Output Amplifier
Sensor Interface
Piezo Electric Transducer Amplifier
Medical Instrumentation
Mobile Communication
Portable Systems
Smoke Detectors
Notebook PC
PCMCIA cards
Battery -Powered equipment
DSP interface

PIN CONFIGURATION (Top View)

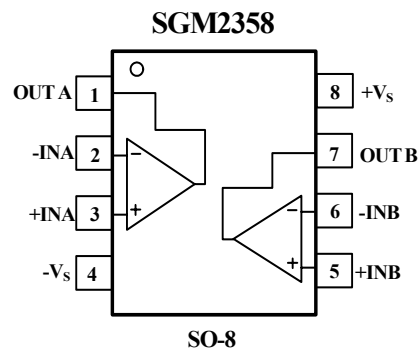

Shengbang Microelectronics Co, Ltd
Tel: 86/451/84348461
www.sg-micro.com

REV. B

ELECTRICAL CHARACTERISTICS : $V_S = +5V$

(At $R_L = 100k\Omega$ connected to $V_S/2$, and $V_{OUT} = V_S/2$, unless otherwise noted)

PARAMETER	CONDITION	SGM2358					
		TYP	MIN/MAX OVER TEMPERATURE			UNITS	MIN / MAX
		+25°C	+25°C	-40°C to +85°C			
INPUT CHARACTERISTICS							
Input Offset Voltage (V_{OS})		1.7	7	7.5	mV	MAX	
Input Bias Current (I_B)		10			pA	TYP	
Input Offset Current (I_{OS})		10			pA	TYP	
Common-Mode Rejection Ratio (CMRR)	$V_S = 5V, V_{CM} = -0.1V$ to 3.3 V	88	70	65	dB	MIN	
Open-Loop Voltage Gain (A_{OL})	$R_L = 2K\Omega, V_O = 0.1V$ to 4.9V	100	85	70	dB	MIN	
	$R_L = 10K\Omega, V_O = 0.035V$ to 4.965V	110	100	90	dB	MIN	
Input Offset Voltage Drift ($\Delta V_{OS}/\Delta T$)		3.5			$\mu V/^\circ C$	TYP	
OUTPUT CHARACTERISTICS							
Output Voltage Swing from Rail	$R_L = 2K\Omega$	0.8			V	TYP	
	$R_L = 10K\Omega$	0.008			V	TYP	
Output Current (I_{OUT})		43	35	30	mA	MIN	
POWER SUPPLY							
Operating Voltage Range			3.0	3.0	V	MIN	
			5.5	5.5	V	MAX	
Power Supply Rejection Ratio (PSRR)	$V_S = +3V$ to + 5.5 V						
	$V_{CM} = (-V_S) + 0.5V$	80	70	65	dB	MIN	
Quiescent Current / Amplifier (I_Q)	$I_{OUT} = 0$	0.4	0.95	1	mA	MAX	
DYNAMIC PERFORMANCE							
	$C_L = 100pF$						
Gain-Bandwidth Product (GBP)		1.0			MHz	TYP	
Slew Rate (SR)	$G = +1, 2V$ Output Step	0.65			V/ μs	TYP	
Settling Time to 0.1% (t_s)	$G = +1, 2V$ Output Step	9.0			μs	TYP	
Overload Recovery Time	$V_{IN} \cdot Gain = V_S$	4.0			μs	TYP	
Crosstalk	1KHz	-80			dB	TYP	
	1MHz	-65			dB	TYP	
NOISE PERFORMANCE							
Voltage Noise Density (e_n)	$f = 1kHz$	42			nV/\sqrt{Hz}	TYP	
	$f = 10kHz$	38			nV/\sqrt{Hz}	TYP	

Specifications subject to change without notice.

PACKAGE/ORDERING INFORMATION

MODEL	ORDER NUMBER	PACKAGE DESCRIPTION	SPECIFIED TEMPERATURE RANGE	PACKAGE OPTION	MARKING INFORMATION
SGM2358	SGM2358YS/TR	SO-8	-40°C to +85°C	Tape and Reel, 2500	SGM2358YS

ABSOLUTE MAXIMUM RATINGS

Supply Voltage, V+ to V-	6.0 V
Storage Temperature Range	-65°C to +150°C
Junction Temperature	160°C
Operating Temperature Range	-40°C to +85°C
Package Thermal Resistance @ T _A = 25°C	
SO-8, θ _{JA}	125°C/W
Lead Temperature Range (Soldering 10 sec)	
	260°C
ESD Susceptibility	
HBM	4000V
MM	300V

NOTES

1. Stresses above those listed under Absolute Maximum Ratings may cause permanent damage to the device. This is a stress rating only; functional operation of the device at these or any other conditions above those indicated in the operational section of this specification is not implied. Exposure to absolute maximum rating conditions for extended periods may affect device reliability.

CAUTION

This integrated circuit can be damaged by ESD. Shengbang Micro-electronics recommends that all integrated circuits be handled with appropriate precautions. Failure to observe proper handling and installation procedures can cause damage.

ESD damage can range from subtle performance degradation to complete device failure. Precision integrated circuits may be more susceptible to damage because very small parametric changes could cause the device not to meet its published specifications.

TYPICAL PERFORMANCE CHARACTERISTICS

At $T_A = +25^\circ\text{C}$, $V_S = +5\text{V}$, and $R_L = 100\text{k}\Omega$ connected to $V_S/2$, unless otherwise noted.

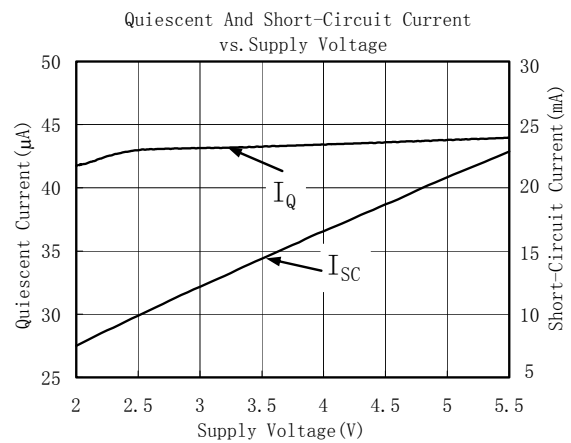
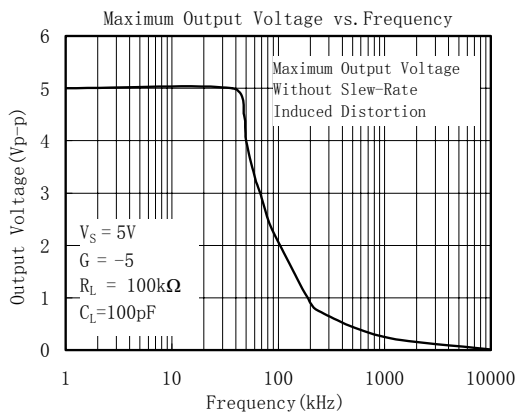
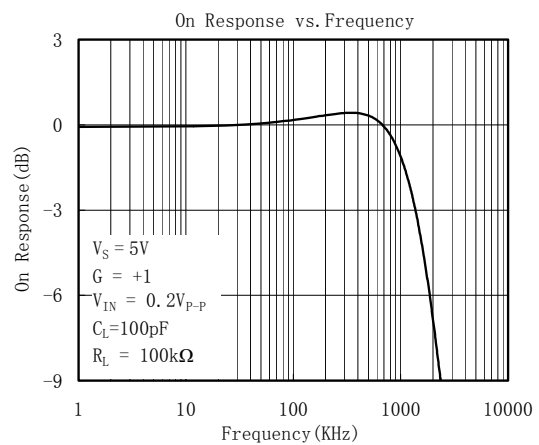
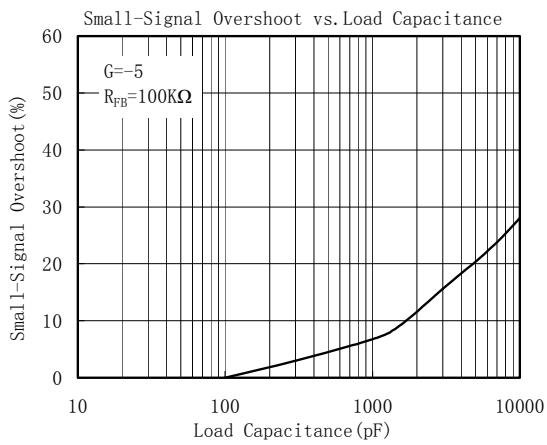
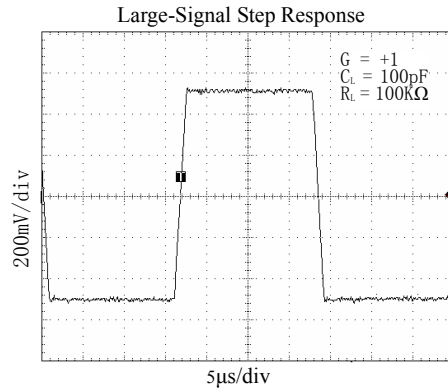
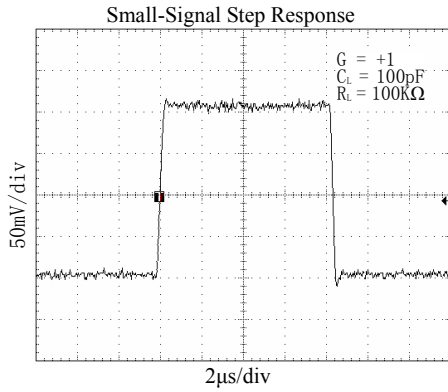

TYPICAL PERFORMANCE CHARACTERISTICS

At $T_A = +25^\circ\text{C}$, $V_S = +5\text{V}$, and $R_L = 100\text{k}\Omega$ connected to $V_S/2$, unless otherwise noted.

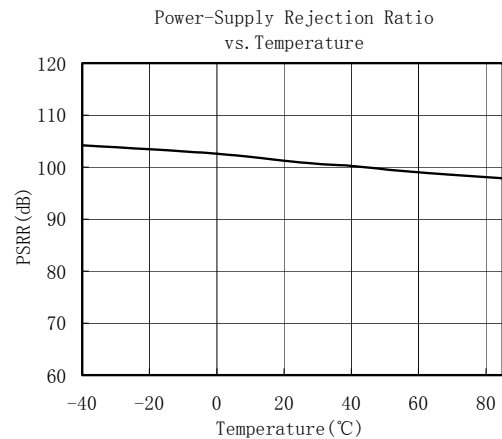
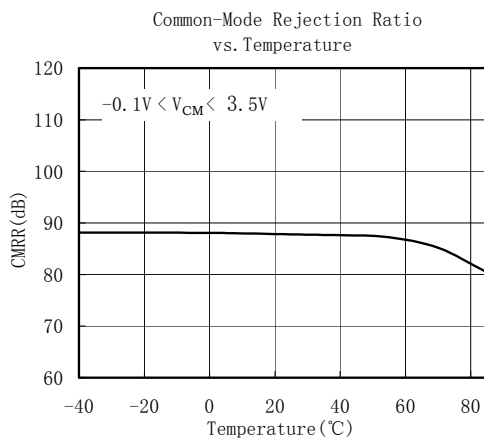
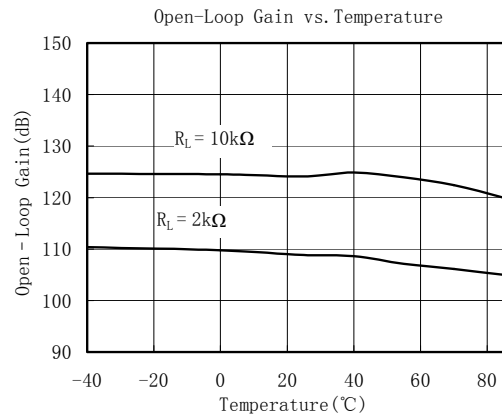
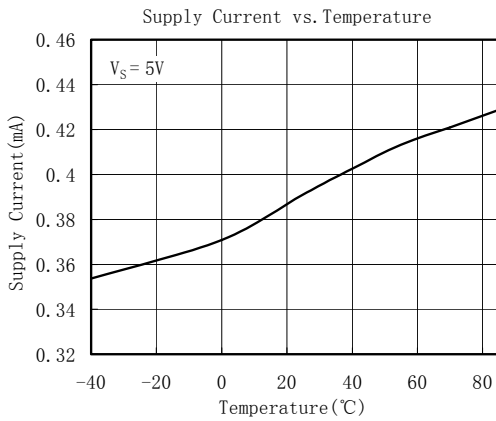
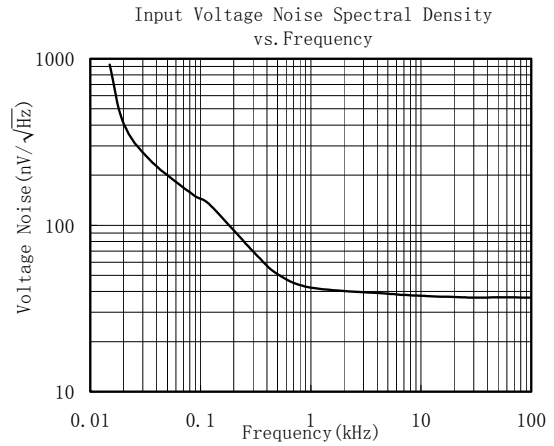
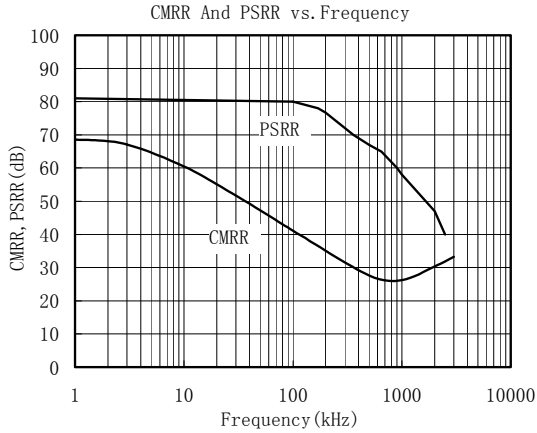

TYPICAL PERFORMANCE CHARACTERISTICS

At $T_A = +25^\circ\text{C}$, $V_S = +5\text{V}$, and $R_L = 100\text{k}\Omega$ connected to $V_S/2$, unless otherwise noted.

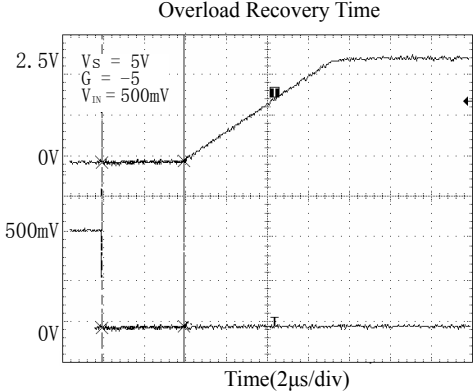

APPLICATION NOTES

Driving Capacitive Loads

The SGM2358 can directly drive 250pF in unity-gain without oscillation. The unity-gain follower (buffer) is the most sensitive configuration to capacitive loading. Direct capacitive loading reduces the phase margin of amplifiers and this results in ringing or even oscillation. Applications that require greater capacitive drive capability should use an isolation resistor between the output and the capacitive load like the circuit in Figure 1. The isolation resistor R_{ISO} and the load capacitor C_L form a zero to increase stability. The bigger the R_{ISO} resistor value, the more stable V_{OUT} will be. Note that this method results in a loss of gain accuracy because R_{ISO} forms a voltage divider with the R_{LOAD} .

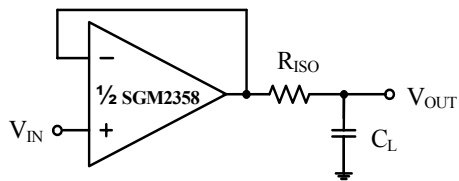

Figure 1. Indirectly Driving Heavy Capacitive Load

An improvement circuit is shown in Figure 2, It provides DC accuracy as well as AC stability. R_F provides the DC accuracy by connecting the inverting signal with the output, C_F and R_{ISO} serve to counteract the loss of phase margin by feeding the high frequency component of the output signal back to the amplifier's inverting input, thereby preserving phase margin in the overall feedback loop.

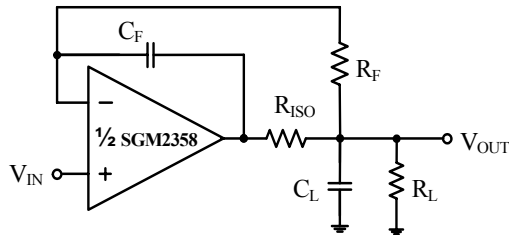

Figure 2. Indirectly Driving Heavy Capacitive Load with DC Accuracy

For no-buffer configuration, there are two others ways to increase the phase margin: (a) by increasing the amplifier's gain or (b) by placing a capacitor in parallel with the feedback resistor to counteract the parasitic capacitance associated with inverting node.

Power-Supply Bypassing and Layout

The SGM2358 operates from either a single +3V to +5.5V supply or dual $\pm 1.5V$ to $\pm 2.75V$ supplies. For single-supply operation, bypass the power supply V_{DD} with a $0.1\mu F$ ceramic capacitor which should be placed close to the V_{DD} pin. For dual-supply operation, both the V_{DD} and the V_{SS} supplies should be bypassed to ground with separate $0.1\mu F$ ceramic capacitors. $2.2\mu F$ tantalum capacitor can be added for better performance.

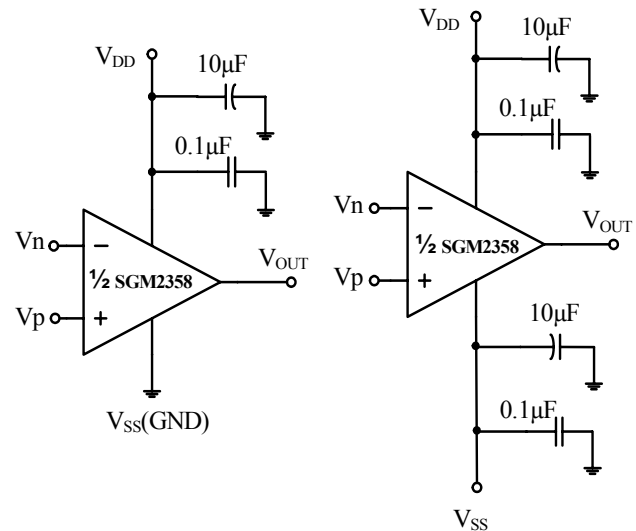

Figure 3. Amplifier with Bypass Capacitors

Typical Application Circuits

Differential Amplifier

The circuit shown in Figure 4 performs the difference function. If the resistors ratios are equal ($R4 / R3 = R2 / R1$), then $V_{OUT} = (Vp - Vn) \times R2 / R1 + Vref$.

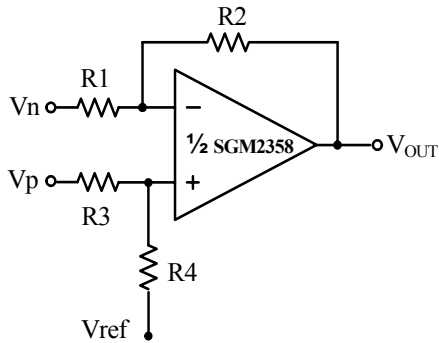

Figure 4. Differential Amplifier

Instrumentation Amplifier

The circuit in Figure 5 performs the same function as that in Figure 4 but with the high input impedance.

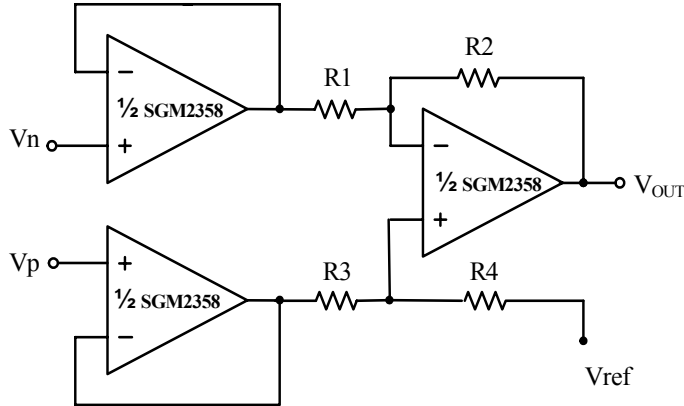

Figure 5. Instrumentation Amplifier

Low Pass Active Filter

The low pass filter shown in Figure 6 has a DC gain of ($- R2 / R1$) and the -3dB corner frequency is $1/2\pi R2C$. Make sure the filter is within the bandwidth of the amplifier. The Large values of feedback resistors can couple with parasitic capacitance and cause undesired effects such as ringing or oscillation in high-speed amplifiers. Keep resistors value as low as possible and consistent with output loading consideration.

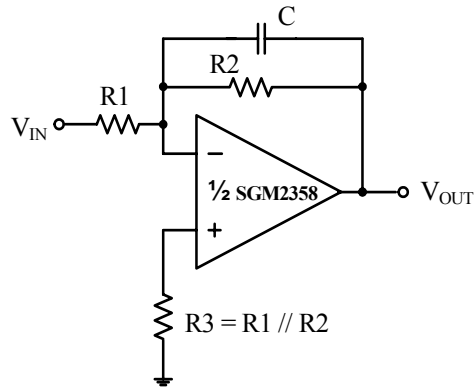
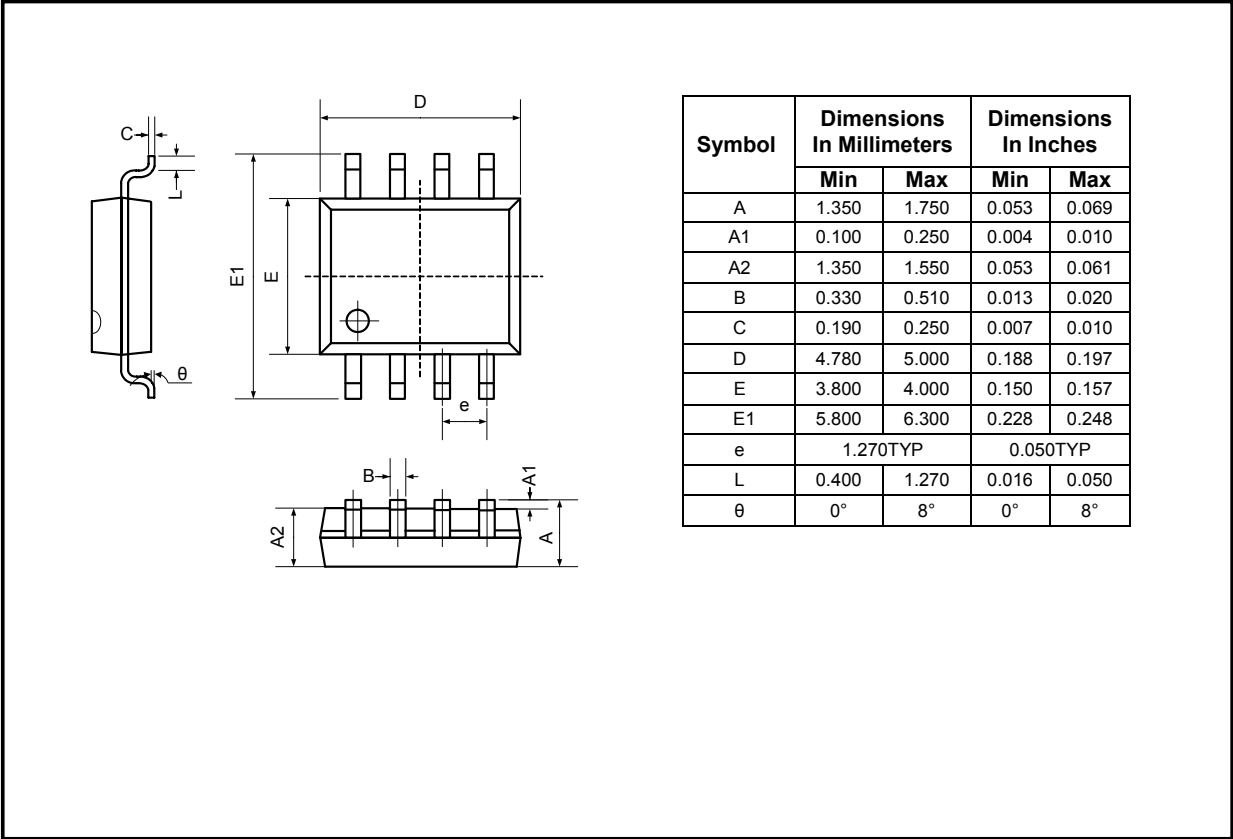

Figure 6. Low Pass Active Filter

PACKAGE OUTLINE DIMENSIONS

SO-8



REVISION HISTORY

Location	Page
09/07— Data Sheet REV. A	
10/07— Data Sheet changed from REV.A to REV.B	
Changes to ELECTRICAL CHARACTERISTICS about Noise.	2
Changes to TYPICAL PERFORMANCE CHARACTERISTICS about Noise.	5

Shengbang Microelectronics Co, Ltd

Unit 3, ChuangYe Plaza
No.5, TaiHu Northern Street, YingBin Road Centralized Industrial Park
Harbin Development Zone
Harbin, HeiLongJiang 150078
P.R. China
Tel.: 86-451-84348461
Fax: 86-451-84308461
www.sg-micro.com