

Low Phase Noise VCXO (20MHz to 52MHz)

FEATURES

- VCXO output for the 20MHz to 52MHz range
- Low phase noise (-130 dBc @ 10kHz offset at 52MHz).
- CMOS output with OE tri-state control.
- 20 to 52MHz fundamental crystal input.
- Integrated high linearity variable capacitors.
- 12mA drive capability at TTL output.
- +/- 150 ppm pull range, max 5% linearity.
- Low jitter (RMS): 4ps period jitter.
- 2.25V to 3.63V DC operation.
- Available in die.

PAD LAYOUT

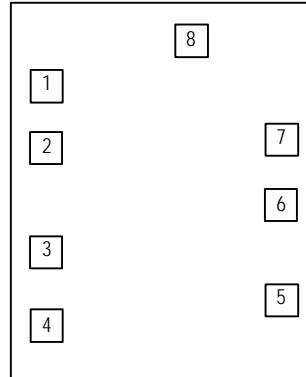

DESCRIPTION

The PLL500-20 is a low cost, high performance and low phase noise VCXO for the 20 to 52MHz range, providing less than -130dBc at 10kHz offset at 52MHz. The very low jitter (4 ps RMS period jitter) makes this chip ideal for applications requiring voltage controlled frequency sources. Input crystal can range from 20 to 52MHz (fundamental resonant mode).

FREQUENCY RANGE

MULTIPLIER	FREQUENCY	OUTPUT BUFFER
1x	20 – 52 MHz	CMOS

BLOCK DIAGRAM

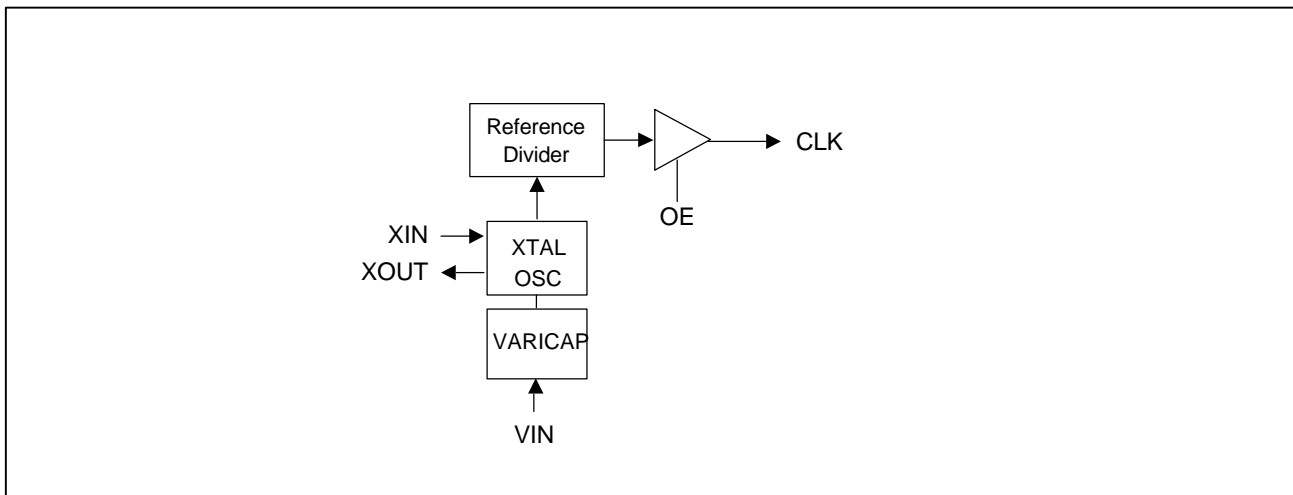

Low Phase Noise VCXO (20MHz to 52MHz)
PAD DESCRIPTION

Name	Number	Type	Description
XOUT	1	I	Crystal output pin.
OE	2	I	Output Enable input pin. Tri-states output if low. Enables output if high.
VIN	3	I	Frequency control voltage input pin.
GND	4	P	Ground pin.
CLK	5	O	Output clock pin.
VDD	6	P	+3.3V VDD power supply pin.
OE	7	I	Output Enable input pin. Tri-states output if low. Enables output if high.
XIN	8	I	Crystal input pin.

See also pad coordinates table at the end of this document.

ELECTRICAL SPECIFICATIONS
1. Absolute Maximum Ratings

PARAMETERS	SYMBOL	MIN.	MAX.	UNITS
Supply Voltage Range	V _{CC}	-0.5	7	V
Input Voltage Range	V _I	-0.5	V _{CC} +0.5	V
Output Voltage Range	V _O	-0.5	V _{CC} +0.5	V
Soldering Temperature			260	°C
Storage Temperature	T _S	-65	150	°C
Ambient Operating Temperature*		-40	85	°C

Exposure of the device under conditions beyond the limits specified by Maximum Ratings for extended periods may cause permanent damage to the device and affect product reliability. These conditions represent a stress rating only, and functional operations of the device at these or any other conditions above the operational limits noted in this specification is not implied.

* **Note:** Operating Temperature is guaranteed by design for all parts (COMMERCIAL and INDUSTRIAL), but tested for INDUSTRIAL grade only.

Low Phase Noise VCXO (20MHz to 52MHz)
2. AC Electrical Specifications

PARAMETERS	SYMBOL	CONDITIONS	MIN.	TYP.	MAX.	UNITS
Input Crystal Frequency			20		52	MHz
Output Clock Rise/Fall Time		0.8V ~ 2.0V with 10 pF load		1.15		ns
		0.3V ~ 3.0V with 15 pF load		3.7		
Output Clock Duty Cycle		Measured @ 1.4V	45	50	55	%
Short Circuit Current				±50		mA

3. Voltage Control Crystal Oscillator

PARAMETERS	SYMBOL	CONDITIONS	MIN.	TYP.	MAX.	UNITS
VCXO Stabilization Time *	T _{VCXOSTB}	From power valid		10		ms
VCXO Tuning Range		F _{XIN} = 20 – 52MHz; XTAL C ₀ /C ₁ < 250	300			ppm
CLK output pullability		0V ≤ V _{IN} ≤ 3.3V	±150			ppm
VCXO Tuning Characteristic				100		ppm/V
Pull range linearity					5	%
Power Supply Rejection	PWSRR	Frequency change with V _{dd} varied +/- 10%		tbd		ppm
VIN pin input impedance			1000			kΩ
VIN modulation BW		0V ≤ V _{IN} ≤ 3.3V, -3dB	45			kHz

Note: Preliminary Specifications still to be characterized. Parameters denoted with an asterisk (*) represent nominal characterization data and are not production tested to any specific limits.

4. Jitter and Phase Noise specification

PARAMETERS	CONDITIONS	MIN.	TYP.	MAX.	UNITS
RMS Period Jitter (1 sigma – 1000 samples)	with capacitive decoupling between VDD and GND.		4		ps
Phase Noise relative to carrier	52MHz @100Hz offset		-80		dBc/Hz
Phase Noise relative to carrier	52MHz @1kHz offset		-110		dBc/Hz
Phase Noise relative to carrier	52MHz @10kHz offset		-130		dBc/Hz
Phase Noise relative to carrier	52MHz @100kHz offset		-138		dBc/Hz
Phase Noise relative to carrier	52MHz @1MHz offset		-145		dBc/Hz

Note: Preliminary Specifications still to be characterized.

Low Phase Noise VCXO (20MHz to 52MHz)
5. DC Specification

PARAMETERS	SYMBOL	CONDITIONS	MIN.	TYP.	MAX.	UNITS
Supply Current, Dynamic, with Loaded Outputs	I_{DD}	$F_{XIN} = 52\text{MHz}$ Output load of 15pF		7	10	mA
Operating Voltage	V_{DD}		2.25		3.63	V
Output High Voltage	V_{OH}	$I_{OH} = -12\text{mA}$	2.4			V
Output Low Voltage	V_{OL}	$I_{LO} = 12\text{mA}$			0.4	V
Output High Voltage at CMOS level	V_{OHC}	$I_{OH} = -4\text{mA}$	$V_{DD} - 0.4$			V
Output drive current		At TTL level	12	17		mA
Short Circuit Current				± 50		mA
VCXO Control Voltage	V_{IN}		0		3.3	V
ESD Protection		Human Body Model	3000			

6. Crystal Specifications

PARAMETERS	SYMBOL	MIN.	TYP.	MAX.	UNITS
Crystal Resonator Frequency	F_{XIN}	20		52	MHz
Crystal Loading Rating ($V_{IN} = 1.65\text{V}$)	C_L (xtal)		14		pF
Drive Level			500		μW
C_0				5	pF
C_0/C_1				250	-
ESR	R_s			30	Ω

Note: The crystal must be such that it oscillates (parallel resonant) at nominal frequency when presented a C Load as specified above. If the crystal requires more load to be at nominal frequency, the additional load must be added externally. This however may reduce the pull range.

Low Phase Noise VCXO (20MHz to 52MHz)

PAD ASSIGNMENT

Pad #	Name	X (μm)	Y (μm)
1	XOUT	TBD	TBD
2	VIN	TBD	TBD
3	OE	TBD	TBD
4	GND	TBD	TBD
5	CLK	TBD	TBD
6	VDD	TBD	TBD
7	OE	TBD	TBD
8	XIN	TBD	TBD

Die dimensions and reference coordinates in μm excluding scribe lines:

Lower left: X=0, Y=0
Upper right: X=812, Y=986

ORDERING INFORMATION

For part ordering, please contact our Sales Department:

47745 Fremont Blvd., Fremont, CA 94538, USA
Tel: (510) 492-0990 Fax: (510) 492-0991

PART NUMBER

The order number for this device is a combination of the following:
Device number, Package type and Operating temperature range

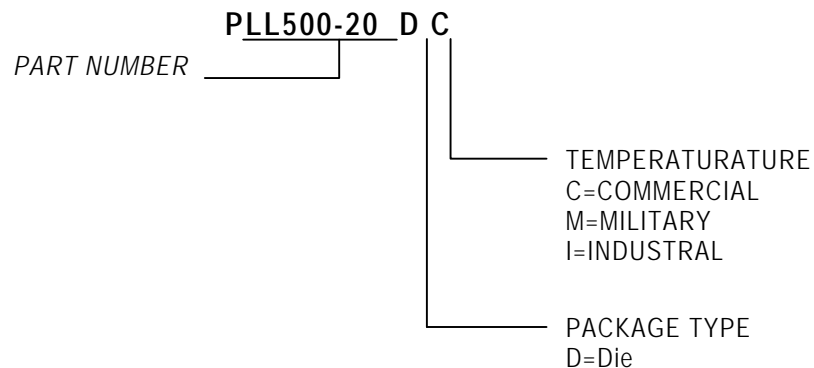

PhaseLink Corporation, reserves the right to make changes in its products or specifications, or both at any time without notice. The information furnished by Phaselink is believed to be accurate and reliable. However, PhaseLink makes no guarantee or warranty concerning the accuracy of said information and shall not be responsible for any loss or damage of whatever nature resulting from the use of, or reliance upon this product.

LIFE SUPPORT POLICY: PhaseLink's products are not authorized for use as critical components in life support devices or systems without the express written approval of the President of PhaseLink Corporation.