

# MA3X786

## Silicon epitaxial planar type

For super-high speed switching circuit

For small current rectification

### ■ Features

- Allowing to rectify under ( $I_{F(AV)} = 100$  mA) condition
- Optimum for high-frequency rectification because of its short reverse recovery time ( $t_{rr}$ )
- Low  $V_F$  (forward rise voltage), with high rectification efficiency

### ■ Absolute Maximum Ratings $T_a = 25^\circ\text{C}$

Parameter	Symbol	Rating	Unit
Reverse voltage (DC)	$V_R$	30	V
Repetitive peak reverse voltage	$V_{RRM}$	30	V
Peak forward current	$I_{FM}$	300	mA
Average forward current	$I_{F(AV)}$	100	mA
Non-repetitive peak forward surge current*	$I_{FSM}$	1	A
Junction temperature	$T_j$	125	$^\circ\text{C}$
Storage temperature	$T_{stg}$	-55 to +125	$^\circ\text{C}$

Note) \* : The peak-to-peak value in one cycle of 50 Hz sine-wave (non-repetitive)

### ■ Electrical Characteristics $T_a = 25^\circ\text{C}$

Parameter	Symbol	Conditions	Min	Typ	Max	Unit
Reverse current (DC)	$I_R$	$V_R = 30$ V			15	$\mu\text{A}$
Forward voltage (DC)	$V_F$	$I_F = 100$ mA			0.55	V
Terminal capacitance	$C_t$	$V_R = 0$ V, $f = 1$ MHz		20		pF
Reverse recovery time*	$t_{rr}$	$I_F = I_R = 100$ mA $I_{rr} = 10$ mA, $R_L = 100$ $\Omega$		2		ns

Note) 1. Schottky barrier diode is sensitive to electric shock (static electricity, etc.). Due attention must be paid on the charge of a human body and the leakage of current from the operating equipment.

2. Rated input/output frequency: 250 MHz
3. \* :  $t_{rr}$  measuring circuit

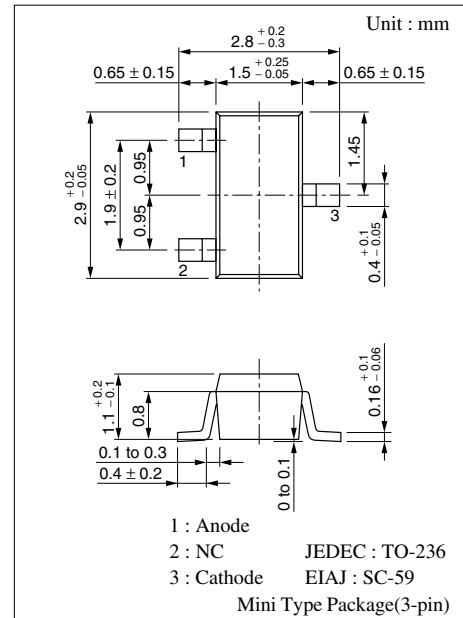
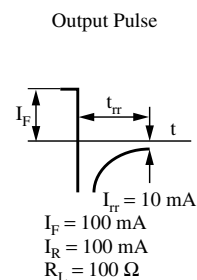
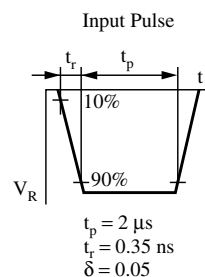
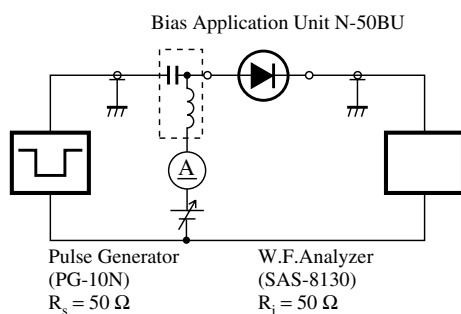

Marking Symbol: M3T

Internal Connection

