



# PL-2301 USB to USB Bridge Controller

## Product Datasheet

---

Document Revision: 1.7

Document Release: October 17, 2005

### **Prolific Technology Inc.**

7F, No. 48, Sec. 3, Nan Kang Rd.  
Nan Kang, Taipei 115, Taiwan, R.O.C.  
Telephone: +886-2-2654-6363  
Fax: +886-2-2654-6161  
E-mail: [sales@prolific.com.tw](mailto:sales@prolific.com.tw)  
Website: <http://www.prolific.com.tw>



## **Disclaimer**

All the information in this document is subject to change without prior notice. Prolific Technology Inc. does not make any representations or any warranties (implied or otherwise) regarding the accuracy and completeness of this document and shall in no event be liable for any loss of profit or any other commercial damage, including but not limited to special, incidental, consequential, or other damages.

## **Trademarks**

The Prolific logo is a registered trademark of Prolific Technology Inc. All brand names and product names used in this document are trademarks or registered trademarks of their respective holders.

## **Copyrights**

**Copyright © 2005 Prolific Technology Inc. All rights reserved.**

No part of this document may be reproduced or transmitted in any form by any means without the express written permission of Prolific Technology Inc.

---

## Revision History

Revision	Description	Date
1.7	➤ Revised PL-2301 Product Datasheet	October 17, 2005

---

## Table of Contents

<b>1.0 FEATURES.....</b>	<b>6</b>
<b>2.0 INTRODUCTION .....</b>	<b>6</b>
<b>3.0 FUNCTIONAL BLOCK DIAGRAM.....</b>	<b>7</b>
<b>4.0 PIN ASSIGNMENT OUTLINE .....</b>	<b>8</b>
<b>5.0 PIN ASSIGNMENT &amp; DESCRIPTION .....</b>	<b>9</b>
<b>6.0 USB STANDARD DESCRIPTORS .....</b>	<b>10</b>
6.1 String Descriptor .....	10
6.2 Device Descriptor .....	10
6.3 Configuration Descriptor .....	11
6.4 Interface Descriptor .....	11
6.5 Endpoint Descriptor: Control Endpoint Descriptor .....	12
6.6 Endpoint 1 Descriptor: Interrupt Endpoint Descriptor .....	12
6.7 Endpoint 2 Descriptor: Bulk-Out Endpoint Descriptor .....	12
6.8 Endpoint 3 Descriptor: Bulk-In Endpoint Descriptor.....	12
<b>7.0 ELECTRICAL, TEMPERATURE &amp; TIMING CHARACTERISTICS.....</b>	<b>13</b>
7.1 Absolute Maximum Ratings .....	13
7.2 DC Characteristics .....	13
7.3 Clock Characteristics .....	13
7.4 USB Transceiver Characteristics .....	14
<b>8.0 ORDERING INFORMATION .....</b>	<b>14</b>
<b>9.0 OUTLINE DIAGRAM.....</b>	<b>15</b>
9.1 SSOP28 Package.....	15

---

## List of Figures

Figure 3-1 Block Diagram of PL-2301 .....	7
Figure 4-1 Pin Assignment Outline of PL-2301 .....	8
Figure 9-1 Outline Diagram of PL-2301 SSOP28 .....	15

## List of Tables

Table 5-1 Pin Assignment & Description .....	9
Table 6-1 String Descriptor .....	10
Table 6-2 Device Descriptor .....	10
Table 6-3 Configuration Descriptor .....	11
Table 6-4 Interface Descriptor .....	11
Table 6-6 Endpoint 1 Descriptor .....	12
Table 6-7 Endpoint 2 Descriptor .....	12
Table 6-8 Endpoint 3 Descriptor .....	12
Table 7-1 Absolute Maximum Ratings .....	13
Table 7-2 DC Characteristics .....	13
Table 7-3 Clock Characteristics .....	13
Table 7-4 USB Transceiver Characteristics .....	14
Table 8-1 Ordering Information .....	14
Table 9-1 Package Dimension .....	15

---

## 1.0 Features

- Transfer files between two PCs thru USB port interface
- Full compliance with the Universal Serial Bus Specification Version 1.13
- USB Full-Speed Connection
- Dual data buffer supporting two-way data transfer
- Low power consumption
- Supports suspend and resume for power management
- Supports remote wake-up
- PnP driver running on Windows 98SE, Windows ME, Windows 2000, and Windows XP.
- Bus powered from either USB port
- Suitable for mobile PC environment
- On-chip USB transceiver
- On-chip oscillator using one 12MHz crystal
- No glue logic needed – can be embedded in small space
- Designed for Windows XP/2000 Certified Logo Drivers
- USB-IF Logo Compliant with [TID 41000098](#)
- 28-Pin SSOP package

## 2.0 Introduction

The PL-2301 operates as a bridge between two PCs (USB host) that are widely utilized in PC-to-PC communication nowadays. With a more advanced bus protocol and operation system, this USB bridge cable could offer much higher bandwidth and easier user interface.

This chip is embedded into a link cable. Either port is an upstream port that could join a USB network, i.e. a PC's USB connector or a USB hub's downstream port. By means of switching and protocol changing in the chip, any two PCs or USB hosts can communicate with each other. The bulk-type data format is adopted for maximum speed. In addition, data are followed to flow in both directions simultaneously without any performance compromising. The PCs can control the device using standard USB command, while the data flow is directed by a vendor-specific scheme.

As shown in the block diagram next page, this ASIC contains two USB units working independently. Together with the two FIFOs and control logics in between, they exchange data with no blocking. All the clock oscillator, PLL, voltage regulators, USB transceivers, and power-on reset circuits are integrated on chip. There is no glue logic needed. This chip is designed for handy cable utility.

### 3.0 Functional Block Diagram

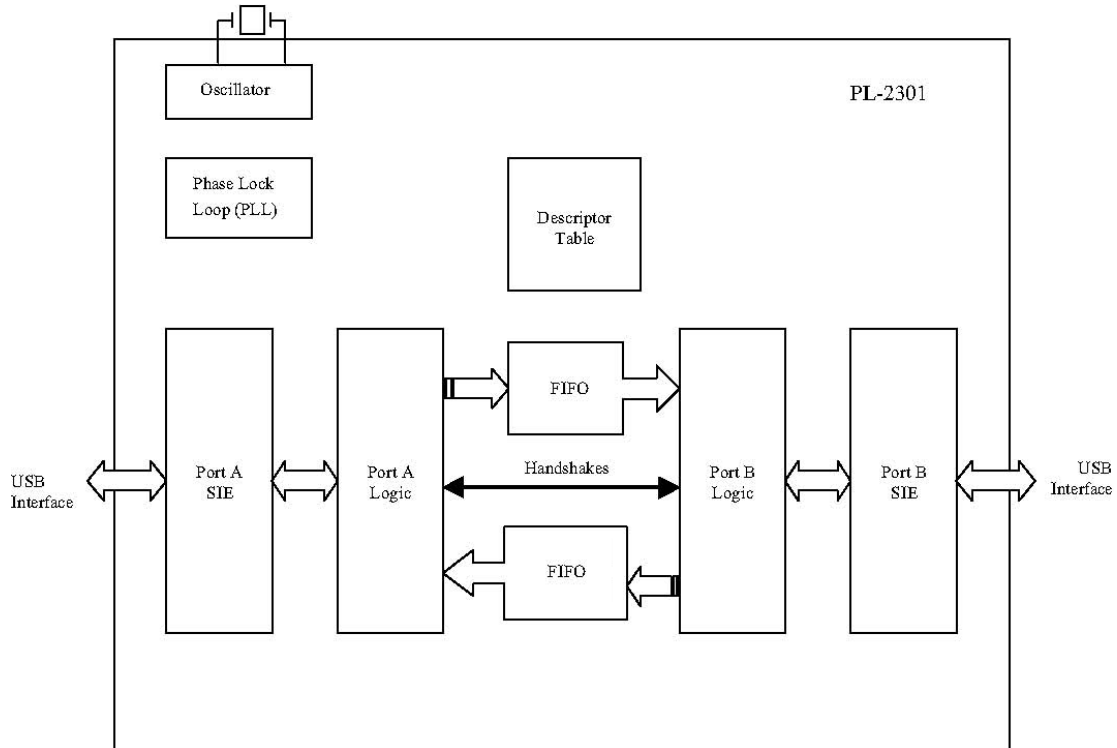
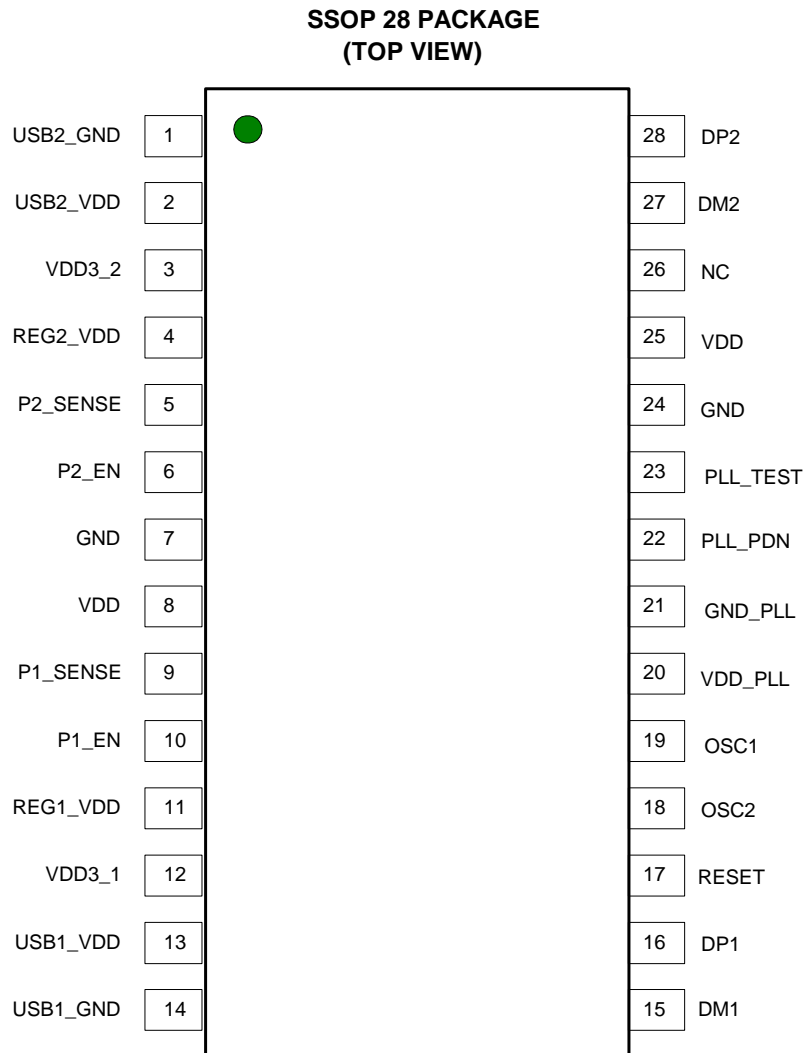

Figure 3-1 Block Diagram of PL-2301

## 4.0 Pin Assignment Outline



**Figure 4-1 Pin Assignment Outline of PL-2301**



## 5.0 Pin Assignment & Description

Table 5-1 Pin Assignment & Description

Pin No.	Name	Type	Description
1	USB2_GND	P	Port 2 USB Ground
2	USB2_VDD	P	Port 2 USB VDD
3	VDD3_2	P	Port 2 Transceiver Power
4	REG2_VDD	P	Regulator Power
5	P2_SENSE	I	Port 2 Sense
6	P2_EN	O	Port 2 Power Enable
7	GND	P	Ground
8	VDD	P	Power
9	P1_SENSE	I	Port 1 Sense
10	P1_EN	O	Port 1 Power Enable
11	REG1_VDD	P	Regulator Power
12	VDD3_1	P	Port 2 Transceiver Power
13	USB1_VDD	P	Port 1 USB VDD
14	USB1_GND	P	Port 1 USB Ground
15	DM1	I/O	Port 1 USB DMINUS Signal
16	DP1	I/O	Port 1 USB DPLUS Signal
17	RESET	I	System Reset
18	OSC2	O	Crystal Oscillator Output
19	OSC1	I	Crystal Oscillator Input
20	VDD_PLL	P	PLL Power
21	GND_PLL	P	PLL Ground
22	PLL_PDN	I	PLL Trigger
23	PLL_TEST	I	PLL Test Mode Control
24	GND	P	Ground
25	VDD	P	VDD
26	NC	N	No Connection
27	DM2	I/O	Port 2 USB DMINUS Signal
28	DP2	I/O	Port 2 USB DPLUS Signal

Type: I – Input signal    O – Output signal    I/O – Bi-directional signal    P – Power/Ground    N – No Connection

## 6.0 USB Standard Descriptors

### 6.1 String Descriptor

The String index 0, by USB Specification, is defined as Language ID. The PL-2301 supports only manufacturer ID accessed by String index 1.

**Table 6-1 String Descriptor**

Offset	Value	Description
0	04h	String Index 0
1	03h	
2:3	0409h	Language ID for English (United States)
4	32h	String Index 1
5	03h	
6:53	00h, 'P'; 00h, 'r'; 00h, 'o'; 00h, 'l'; 00h, 'i'; 00h, 'f'; 00h, 'i'; 00h, 'c'; 00h, ' '; 00h, 'T'; 00h, 'e'; 00h, 'c'; 00h, 'h'; 00h, 'n'; 00h, 'o'; 00h, 'l'; 00h, 'o'; 00h, 'g'; 00h, 'y'; 00h, ' '; 00h, 'l'; 00h, 'n'; 00h, 'c'; 00h, ' ';	"Prolific Technology Inc." 00h is padded for UNICODE.

### 6.2 Device Descriptor

**Table 6-2 Device Descriptor**

Offset	Field	Size	Value	Description
0	<i>bLength</i>	Byte	12h	Size of this descriptor (in bytes)
1	<i>bDescriptorType</i>	Byte	01h	DEVICE descriptor type
2	<i>bcdUSB</i>	Word	0100h	USB Specification Release Number
4	<i>bDeviceClass</i>	Byte	00h	
5	<i>bDeviceSubClass</i>	Byte	00h	
6	<i>bDeviceProtocol</i>	Byte	00h	
7	<i>bMaxPacketSize0</i>	Byte	08h	Maximum packet size for endpoint 0
8	<i>idVendor</i>	Word	067Bh	Vendor ID
10	<i>idProduct</i>	Word	0000h	Product ID
12	<i>bcdDevice</i>	Word	0000h	Release Number (BCD) 0.0
14	<i>iManufacturer</i>	Byte	01h	Manufacturer string descriptor index
15	<i>iProduct</i>	Byte	00h	Product name string descriptor index
16	<i>iSerialNumber</i>	Byte	00h	Serial number string descriptor index
17	<i>bNumConfigurations</i>	Byte	01h	One possible configuration.

### 6.3 Configuration Descriptor

The default configuration descriptor is used, which contains only one interface. When accessed, all the configuration descriptor, the interface descriptor, and all the endpoint descriptors are returned.

**Table 6-3 Configuration Descriptor**

Offset	Field	Size	Value	Description
0	<i>bLength</i>	Byte	09h	Size of this descriptor (in bytes)
1	<i>bDescriptorType</i>	Byte	02h	CONFIGURATION descriptor type
2	<i>wTotalLength</i>	Word	0027h	Total length of data returned for this configuration.
4	<i>bNumInterface</i>	Byte	01h	One interface for this device.
5	<i>bConfigurationValue</i>	Byte	01h	
6	<i>iConfiguration</i>	Byte	00h	
7	<i>bmAttributes</i>	Byte	A0h	Characteristic attributes
8	<i>MaxPower</i>	Byte	32h	Maximum power consumption is 100mA

### 6.4 Interface Descriptor

The interface descriptor contains all relevant definition fully describing the device. There is only one setting for the interface.

**Table 6-4 Interface Descriptor**

Offset	Field	Size	Value	Description
0	<i>BLength</i>	Byte	09h	Size of this descriptor (in bytes)
1	<i>BDescriptorType</i>	Byte	04h	INTERFACE descriptor type
2	<i>BInterfaceNumber</i>	Byte	00h	
3	<i>BAlternateSetting</i>	Byte	00h	
4	<i>BNumEndpoints</i>	Byte	03h	
5	<i>BInterfaceClass</i>	Byte	FFh	Vendor Specific Class
6	<i>BInterfaceSubClass</i>	Byte	00h	
7	<i>BInterfaceProtocol</i>	Byte	00h	
8	<i>IInterface</i>	Byte	00h	

## 6.5 Endpoint Descriptor: Control Endpoint Descriptor

Since endpoint 0 is used as the default control endpoint, there is no dedicated standard or class-specific control endpoint descriptor.

## 6.6 Endpoint 1 Descriptor: Interrupt Endpoint Descriptor

Table 6-6 Endpoint 1 Descriptor

Offset	Field	Size	Value	Description
0	<i>bLength</i>	Byte	07h	Size of this descriptor (in bytes)
1	<i>bDescriptorType</i>	Byte	05h	ENDPOINT descriptor type
2	<i>bEndpointAddress</i>	Byte	81h	Input endpoint
3	<i>bmAttributes</i>	Byte	03h	Transfer type is INTERRUPT
4	<i>wMaxPacketSize</i>	Word	0001h	1 Byte
6	<i>bInterval</i>	Byte	01h	Polling on every 1 ms interval

## 6.7 Endpoint 2 Descriptor: Bulk-Out Endpoint Descriptor

Table 6-7 Endpoint 2 Descriptor

Offset	Field	Size	Value	Description
0	<i>bLength</i>	Byte	07h	Size of this descriptor (in bytes)
1	<i>bDescriptorType</i>	Byte	05h	ENDPOINT descriptor type
2	<i>bEndpointAddress</i>	Byte	02h	Output endpoint
3	<i>bmAttributes</i>	Byte	02h	Transfer type is BULK
4	<i>wMaxPacketSize</i>	Word	0040h	64 bytes
6	<i>bInterval</i>	Byte	00h	Ignored field

## 6.8 Endpoint 3 Descriptor: Bulk-In Endpoint Descriptor

Table 6-8 Endpoint 3 Descriptor

Offset	Field	Size	Value	Description
0	<i>bLength</i>	Byte	07h	Size of this descriptor (in bytes)
1	<i>bDescriptorType</i>	Byte	05h	ENDPOINT descriptor type
2	<i>bEndpointAddress</i>	Byte	83h	Input endpoint
3	<i>bmAttributes</i>	Byte	02h	Transfer type is BULK
4	<i>wMaxPacketSize</i>	Word	0040h	64 bytes
6	<i>bInterval</i>	Byte	00h	Ignored field

## 7.0 Electrical, Temperature & Timing Characteristics

### 7.1 Absolute Maximum Ratings

Table 7-1 Absolute Maximum Ratings

Items	Ratings
Power Supply Voltage	-0.3 to 6.0 V
Input Voltage	-0.3 to VDD+0.3 V
Output Voltage	-0.3 to VDD+0.3 V
Storage Temperature	-55 to 150 °C

### 7.2 DC Characteristics

Table 7-2 DC Characteristics

Parameter	Symbol	Min	Typ	Max	Units
Power Supply Current	$I_{DD}$	0.5	19	24	mA
Input Voltage					
Low	$V_{IL}$	--	--	0.3 $V_{DD}$	V
High	$V_{IH}$	0.7 $V_{DD}$	--	--	V
Output Voltage					
Low	$V_{OL}$	--	--	0.4	V
High	$V_{OH}$	3.5	--	--	V
Input Leakage Current	$I_L$	-1	--	1	uA
Tri-state Leakage Current	$I_{oz}$	-10	--	10	uA
Input Capacitance	$C_{IN}$	--	3	--	Pf
Output Capacitance	$C_{OUT}$	--	3	--	Pf
Bi-directional Buffer Capacitance	$C_{BID}$	--	3	--	Pf
Operating Voltage Range	--	4.1	5	5.25	V
Suspend Current	$I_{SUS}$	--	400	490	uA
Operating Temperature	--	-40	--	85	°C

### 7.3 Clock Characteristics

Table 7-3 Clock Characteristics

Parameter	Min	Typ	Max	Units
Frequency of Operation	11.976	12.000	12.024	MHz
Clock Period	83.1	83.3	83.5	ns
Duty Cycle	45	50	55	%

## 7.4 USB Transceiver Characteristics

Table 7-4 USB Transceiver Characteristics

Parameter	Symbol	Min	Typ	Max	Units
Rise and Fall Times: (10%—90%)	$T_R$	4	8	15	ns
(90%—10%)	$T_F$	4	8	15	ns
Cross Point	$V_{CR}$	1.3	--	2.0	V
Output Impedance	$R_D$	23	28	33	ohm
High Level Output	$V_{OH}$	2.8	--	--	V
Low Level Output	$V_{OL}$	--	--	0.7	V
High Level Input	$V_{IH}$	2.0	--	--	V
Low Level Input	$V_{IL}$	--	--	0.8	V

Note:  $C_L$ : 50pf

## 8.0 Ordering Information

Table 8-1 Ordering Information

Part Number	Package Type
PL-2301	28-pin SSOP
PL-2301 L/F	28-pin SSOP (Lead-Free or Pb-Free)

## 9.0 Outline Diagram

### 9.1 SSOP28 Package

Table 9-1 Package Dimension

Symbol	Millimeter			Inch		
	Min	Nom	Max	Min	Nom	Max
b	0.22		0.38	0.009		0.015
E	7.40	7.80	8.20	0.291	0.307	0.323
E1	5.00	5.30	5.60	0.197	0.209	0.220
L	0.55	0.75	0.95	0.021	0.030	0.037
R1	0.09			0.004		
D	9.9	10.2	10.5	0.390	0.402	0.413
A			2.0			0.079
e		0.65			0.0256	
L1		1.25			0.050	
A1	0.05			0.020		
A2	1.65	1.75	1.85	0.065	0.069	0.073

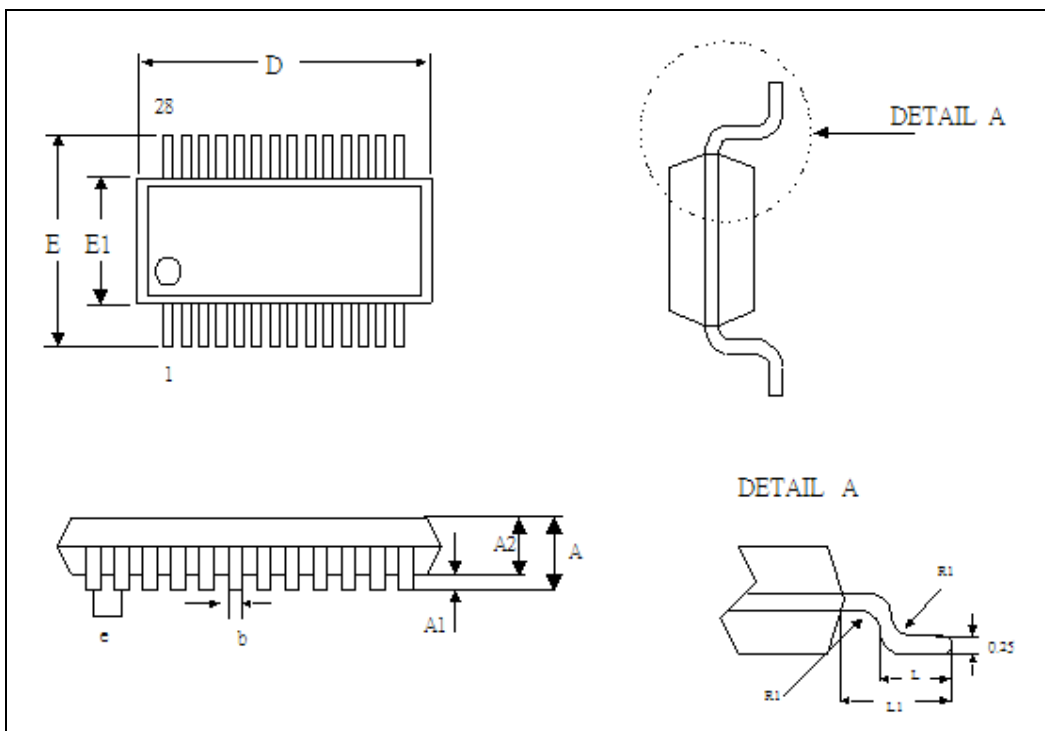

Figure 9-1 Outline Diagram of PL-2301 SSOP28