

**High Speed Translator Buffer to PECL (Enable Low)**

**FEATURES**

- Differential PECL output
- Single AC coupled input (min. 100mV swing).
- Input range from DC to 1.3 GHz.
- 3.3V operation.
- Available in 3x3mm QFN.

**DESCRIPTIONS**

The PLL130-05 is a low cost, high performance, high speed, buffer that reproduces any input frequency from DC to 1.3GHz. It provides a pair of differential PECL output. Any input signal with at least 100mV swing can be used as reference signal. This chip is ideal for conversion from sine wave, TTL, CMOS, or LVDS to PECL.

**BLOCK DIAGRAM**

**PIN CONFIGURATION**

(TOP VIEW)

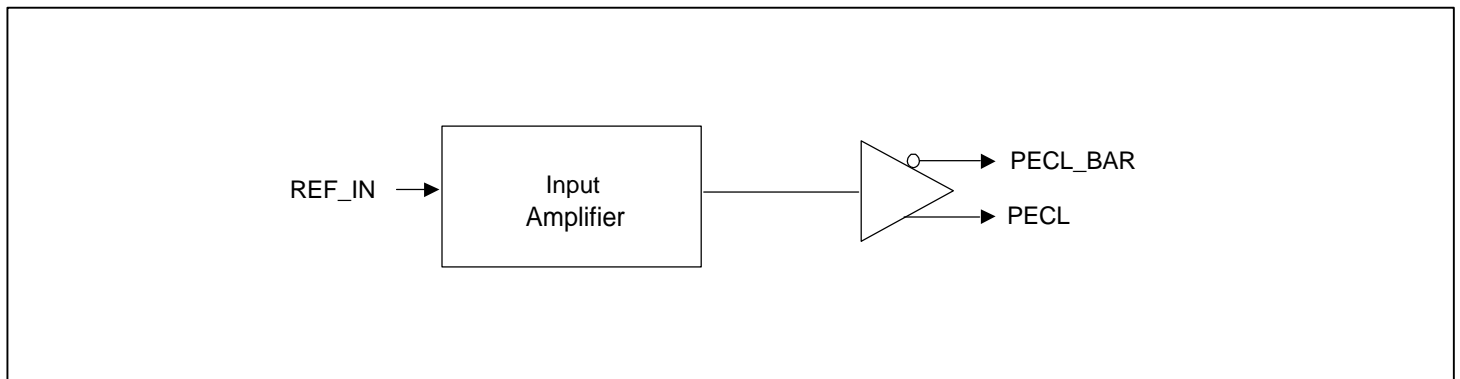
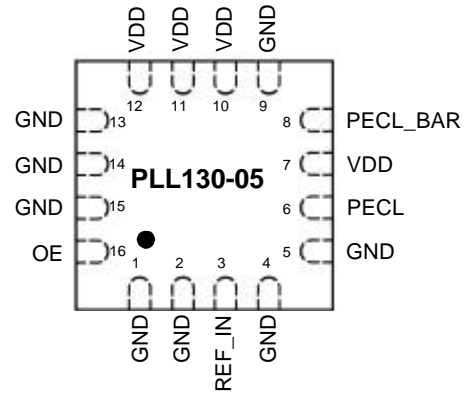

## High Speed Translator Buffer to PECL (Enable Low)

### PIN DESCRIPTIONS

Name	8pin SOIC Pin number	3x3mm QFN Pin number	Type	Description
GND	(use PLL130-08)	1,2,4,5, 9,13,14,15	P	Ground connector
VDD	(use PLL130-08)	7,10,11,12	P	3.3V Power supply
REF_IN	(use PLL130-08)	3	I	Reference input signal. The frequency of this signal will be reproduced at the output (after translation to PECL level).
PECL	(use PLL130-08)	6	O	PECL True output.
PECL_BAR	(use PLL130-08)	8	O	PECL Complementary output.
OE	(use PLL130-08)	16	I	Output enable ('0' for enable). Internal pull-down (default is '0').

### ELECTRICAL SPECIFICATIONS

#### 1. Absolute Maximum Ratings

PARAMETERS	SYMBOL	MIN.	MAX.	UNITS
Supply Voltage Range	$V_{CC}$	-0.5	7	V
Input Voltage Range	$V_I$	-0.5	$V_{CC}+0.5$	V
Output Voltage Range	$V_O$	-0.5	$V_{CC}+0.5$	V
Soldering Temperature			260	°C
Storage Temperature	$T_S$	-65	150	°C
Ambient Operating Temperature*	$T_A$	-40	85	°C

Exposure of the device under conditions beyond the limits specified by Maximum Ratings for extended periods may cause permanent damage to the device and affect product reliability. These conditions represent a stress rating only, and functional operations of the device at these or any other conditions above the operational limits noted in this specification is not implied.

\* **Note:** Operating Temperature is guaranteed by design for all parts (COMMERCIAL and INDUSTRIAL), but tested for INDUSTRIAL grade only.

#### 2. AC Specification

PARAMETERS	CONDITIONS	MIN.	TYP.	MAX.	UNITS
Input Frequency		0		1300	MHz
Input signal swing	REF_IN input	100			mV
Output Frequency		0		1300	MHz
Output Rise Time	0.8V to 2.0V with no load			1.5	ns
Output Fall Time	2.0V to 0.8V with no load			1.5	ns

**High Speed Translator Buffer to PECL (Enable Low)**

**3. PECL Electrical Characteristics**

PARAMETERS	SYMBOL	CONDITIONS	MIN.	MAX.	UNITS
Output High Voltage	$V_{OH}$	$R_L = 50 \Omega$ to $(V_{DD} - 2V)$ (see figure)	$V_{DD} - 1.025$		V
Output Low Voltage	$V_{OL}$			$V_{DD} - 1.620$	V

**4. PECL Switching Characteristics**

PARAMETERS	SYMBOL	CONDITIONS	MIN.	TYP.	MAX.	UNITS
Clock Rise Time	$t_r$	@20/80% - PECL		0.6	1.5	ns
Clock Fall Time	$t_f$	@80/20% - PECL		0.5	1.5	ns

PECL Levels Test Circuit

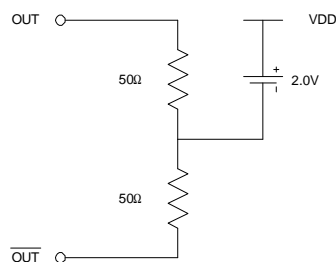

PECL Output Skew

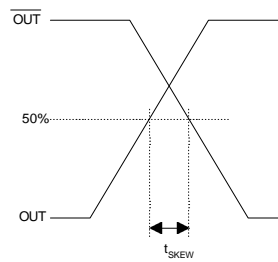

PECL Transition Time Waveform

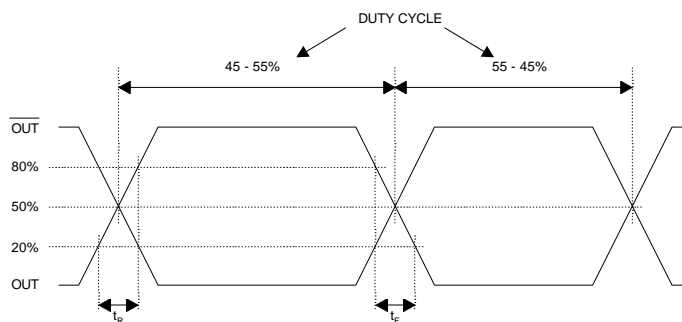

**High Speed Translator Buffer to PECL (Enable Low)**

**PACKAGE INFORMATION**

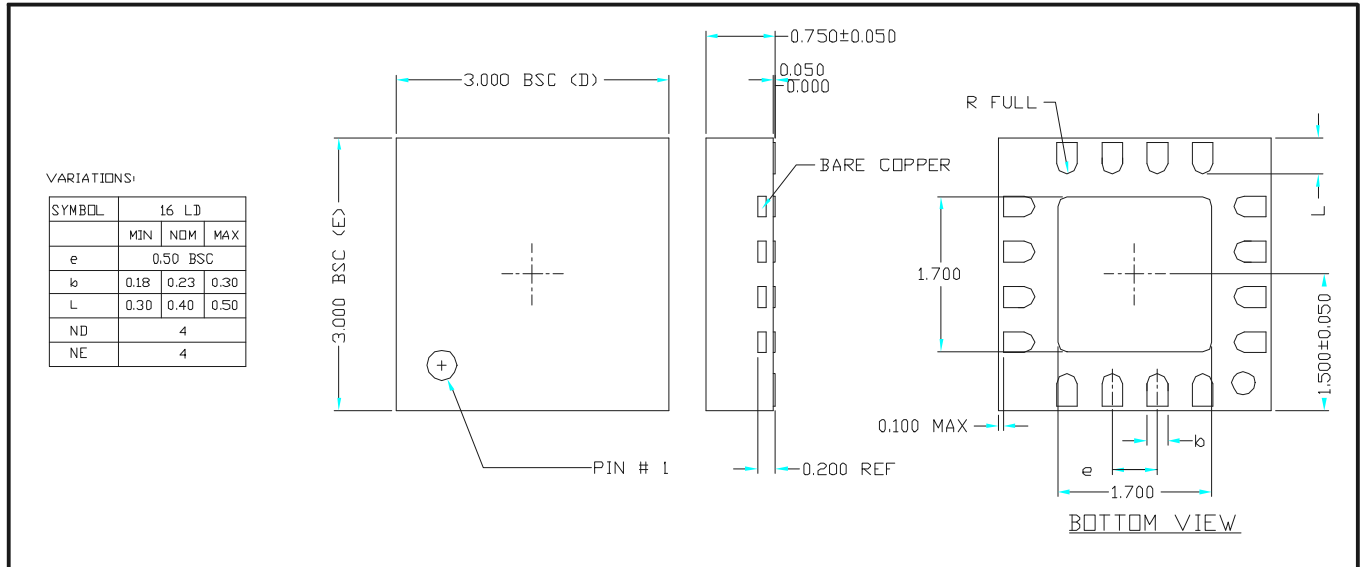

**High Speed Translator Buffer to PECL (Enable Low)**

**ORDERING INFORMATION**

*For part ordering, please contact our Sales Department:*

47745 Fremont Blvd., Fremont, CA 94538, USA  
Tel: (510) 492-0990 Fax: (510) 492-0991

**PART NUMBER**

The order number for this device is a combination of the following:  
Device number, Package type and Operating temperature range

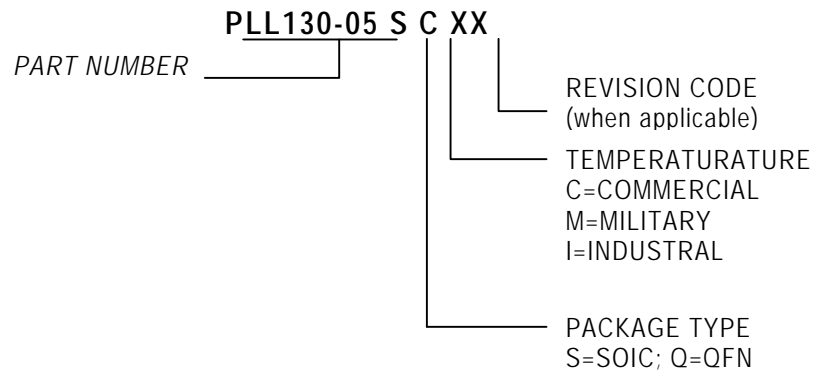

*PhaseLink Corporation, reserves the right to make changes in its products or specifications, or both at any time without notice. The information furnished by Phaselink is believed to be accurate and reliable. However, PhaseLink makes no guarantee or warranty concerning the accuracy of said information and shall not be responsible for any loss or damage of whatever nature resulting from the use of, or reliance upon this product.*

**LIFE SUPPORT POLICY:** PhaseLink's products are not authorized for use as critical components in life support devices or systems without the express written approval of the President of PhaseLink Corporation.