

Product Brief

Zoran Corporation
1390 Kifer Road
Sunnyvale, CA 94086-5305

www.zoran.com



The PM-1100 is an all-digital Pulse Width Modulator (PWM) and frequency synthesizer designed with features and performance to give OEM's products outstanding color and monochrome print quality. The PWM provides unprecedented precision control of pulse width and position allowing original equipment

manufacturers (OEMs) to implement complex image processing for distinct advantages in the marketplace. The integration of a digital frequency synthesizer and rich feature set enables manufacturers to meet stringent quality requirements, scales of integration and outstanding performance.

Benefits

- Provides exceptional precision control of pulse width and position
- Enables complex image processing for distinct advantages in the marketplace
- Fully digital, self-calibrating modulator
- All-digital design guarantees high accuracy without requiring discrete components or calibration cycles
- Internal frequency synthesizer to generate pixel clock

Description

Digital Frequency Synthesizer

The PM-1100 is a fully digital and self-calibrating design based on a free running loop of delay elements. Combined with front-end logic to perform the required arithmetic calculations, the Arbitrary Waveform Synthesizer (AWS) can generate any desired output waveform based on a single reference clock input. The PM-1100 expands the use of the AWS by integrating a frequency synthesizer with a PWM. The integrated frequency synthesizer eliminates the need of generating the video clock in the OEM controller. The digital frequency synthesizer will generate the video pixel clock from an independent arbitrary input reference clock (30 MHz to 66 MHz). The frequency synthesizer and PWM are implemented using the same AWS technology. The two functionalities are merged into a single module, with two separate arithmetic front ends. The generation of the video clock and the video output pulse are performed simultaneously in a single module, leading to the elimination of clock jitter and noise, providing unprecedented precision of the output pulse. In addition, this integration leads to great flexibility in manipulating the video clock, as the PM-1100 incorporates a feature where the video clock frequency can be dynamically varied within a scan line.

Key Features

- Digital frequency synthesizer merged with PWM
- Video clock output from frequency synthesizer
- Operates with arbitrary reference clock (30 MHz - 66 MHz)
- Pulse addressability – (up to 10 bit pulse width / 7 bit pulse position)
- 100 MHz maximum video rate
- LVDS or TTL video output
- Single or dual pixel data I/O with integrated FIFO to accommodate high speed applications
- Automatic and continuous self-calibration
- Integrated Beam Detect synchronization – multi beam support
- Integrated look-up-tables for pulse width and position calibration
- Frequency sweep – dynamically vary video clock frequency within scan line
- Margin control
- Seamless pixel joining—zero dead space

Precision Video Pulse Placement

The PM-1100 Precision Digital Modulator allows designers to adjust the pulse width, position and polarity in each pixel cell of the image, enabling superior edge and photo reproduction and enhancement. The PM-1100 controls video pulse width from 0-100% of a pixel clock period with 10-bit precision. Regardless of the mode chosen, 1024 addressable pulse widths are available with the use of the ILUT. The precision modulator can position a pulse with up to 7-bit precision within a pixel period. In addition the polarity of any pulse can be inverted.

Beam Detect (BD) Synchronization

Start-of-scan is automatically synchronized to the print engine Beam Detect signal (BD). The modulator uses BD to phase adjust the video cell boundaries to the start of each line within 1/256th of a video clock period, eliminating line-to-line jitter. The PM-1100 also supports BD synchronization in multi-beam systems.

Margin Control

Once initialized by the printer controller, the PM-1100 can provide both horizontal and vertical margins using the following registers: left margin, line length, top margin and number of lines.

Precision Digital Modulator/Synthesizer

Product Brief

Descriptions (continued)

Seamless Pixel Joining

Because of the PM-1100's all-digital design and unique digital addressing of transition edges, pixel joining is totally seamless. There is no "recovery" time or "dead zone" between pixels

Frequency Sweep

The PM-1100 frequency synthesizer has two modes: fixed frequency generation and variable frequency sweep.

- Fixed frequency generation - the fixed mode generates a single fixed pixel width (frequency) throughout the scan line.
- Variable frequency sweep - the sweep mode generates a frequency modulated output using a preprogrammed modulation function in the Frequency Sweep LUT (FS LUT) resulting in the generation of a variable frequency as the laser sweeps across the page.

All-Digital Design

The PM-1100 Precision Modulator technology is a proven 3rd generation design implemented in standard CMOS technology. With its unique design, the modulator uses a single reference clock, eliminating the need for high-speed or multiple clock frequencies.

No External Components

The PM-1100 features an all-digital modulator, requiring no external components such as delay lines, beam detect synchronization logic, external SRAM, etc. The output of the modulator directly feeds the laser diode driver.

PULSE DATA MODES SUPPORTED		* pulses are centered
10/2 bit	10 width / 2 position	
8/4 bit	8 width / 4 position	
6/6 bit	6 width / 6 position	
4/8 bit	4 width / 8 position	
10/0 bit CTR*	10 width / 0 position	
10/0 bit LR**	10 width / 0 position	

No Modulator Chip Calibration

Due to its all-digital design, the PM-1100 is inherently linear; no alignment or calibration of the modulator chip is necessary, as is the case with many analog modulators. The PM-1100 operates at full specification without any tuning of components.

PM-1100 Electrical Specifications

- 1.8v core voltage, 3.3v I/O voltage, 5.0 volt tolerant I/O
- 100 MHz maximum video rate
- 80-pin Lowprofile Quad Flatpack (LQFP) Package

Available Options

- PM-1100 (100 MHz)
- PM-1100G (100 MHz Lead-free)
- PM-1100/40G (40 MHz, Lead-free)

PM-1100 Block Diagram

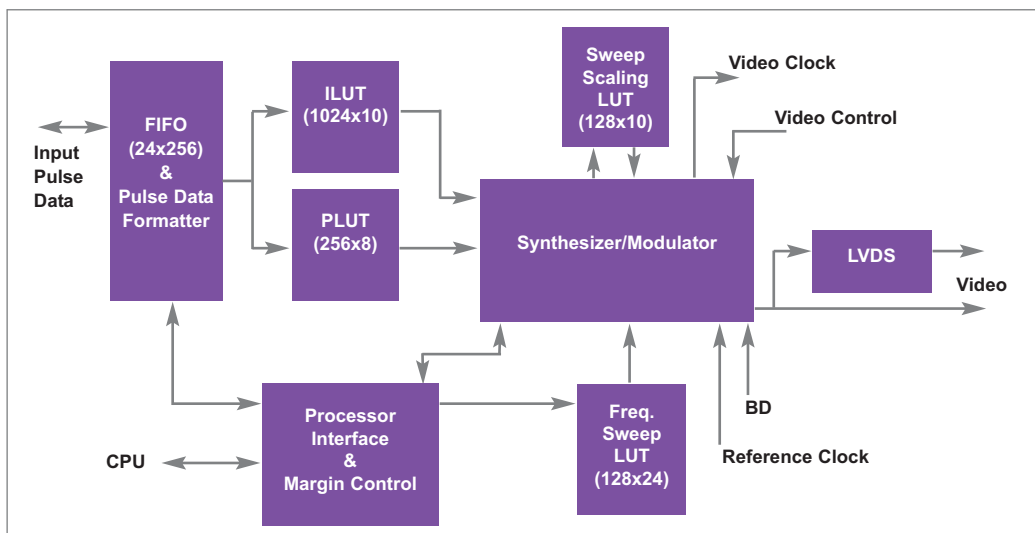

© Copyright 2002-2005 Zoran Corporation. All rights reserved. Zoran and the Zoran logo are trademarks of Zoran Corporation. All other names used are owned by their respective owners. Zoran Corporation makes no guarantee concerning the accuracy of the information contained herein and further does not guarantee that the use of such information will not infringe the rights of any third party. Zoran will not be responsible for any loss or damage of whatever nature resulting from the use of, or reliance upon, the information. Zoran reserves the right to make changes in the product and/or specifications presented herein at any time without notice.