

DESCRIPTION

The AMC3100 is a high efficiency synchronous buck DC/DC converter using a constant frequency, current mode architecture. Adjustable version and fixed output voltages of 1.2V, 1.5V and 1.8V are available. 300uA low supply current at no load and <1uA supply current at shutdown. The 2.5V to 5.5V input voltage range makes the AMC3100 ideally suited for single Li-Ion battery-powered applications. 100% duty cycle provides low dropout operation, extending battery life in portable systems. PWM pulse skipping mode operation provides very low output ripple voltage for noise sensitive applications.

Switching frequency is internally set at 1.5MHz, allowing using small surface mount inductors and capacitors. The internal synchronous switch increases efficiency and eliminates the need for an external Schottky diode. Low output voltages are easily supported with the 0.6V feedback reference voltage.

The AMC3100 is available in a low profile (1mm) Thin SOT-23-5L package.

TYPICAL APPLICATION

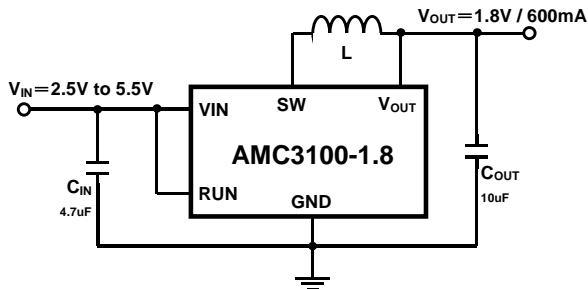

SYMBOLIZATION

Device Name	Output Voltage	Marking
AMC3100DBFT	Adjustable	A64A
AMC3100-1.2DBFT	1.2V Fixed	A642
AMC3100-1.5DBFT	1.5V Fixed	A645
AMC3100-1.8DBFT	1.8V Fixed	A648

FEATURES

- High Efficiency: Up to 96%
- 600mA Output Current at $V_{IN}=3V$
- 2.5V to 5.5V Input Voltage Range
- 1.5MHz Constant Switching Frequency
- No Schottky Diode Required
- 100% Duty Cycle as Low Dropout Operation
- 0.6V Reference Voltage Allows 0.6V Minimum Output Voltage
- <1uA Shutdown Mode Supply Current
- Current Mode Operation for Excellent Line and Load Transient Response
- Over-temperature Protected
- 4KV HBM ESD Protection
- 5-Pin Thin SOT-23 package

APPLICATIONS

- PDA, Personal Media Player
- Smart Phone
- Digital Still Camera, Video Camcorder
- Portable Instruments
- Bluetooth Headset

PACKAGE PIN OUT

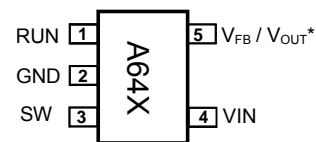

**TSOT-23-5L
(Top View)**

* Note: V_{FB} pin for adjustable version.
 V_{OUT} pin for fixed voltage version.

ORDER INFORMATION

DB	SOT-23
	5-pin
	AMC3100DBF (Adjustable)
	AMC3100-X.XDBF (Fixed Voltage)
Note: 1. All surface-mount packages are available in Tape & Reel. Append the letter "T" to part number (i.e. AMC3100-1.8DBFT). 2. The letter "F" is marked for Lead Free process.	

PIN DESCRIPTION

Pin Number	Pin Name	Pin Function
1	RUN	Enable pin. Higher than 1.5V to turn on the device. Lower than 0.3V to turn it off. The shutdown mode supply current less than $<1\mu\text{A}$ supply current. This pin should not be floating.
2	GND	Ground
3	SW	Power Switch Output. Connects to the drains of the internal P-CH and N-CH MOSFET switches.
4	V_{IN}	Supply Input Pin.
5	$V_{\text{FB}}/V_{\text{OUT}}$	V_{FB} (AMC3100): Feedback Input Pin. Connect V_{FB} to the center point of the external resistor divider. The feedback threshold voltage is 0.6V. V_{OUT} (AMC3100-X.X): Output Voltage Feedback Pin. An internal resistive divider divides the output voltage down for comparison to the internal reference voltage.

PACKAGE THERMAL DATA

Thermal Resistance from Junction to Ambient, θ_{JA}	250 °C /W
Note : Junction Temperature Calculation: $T_j = T_A + (P_D \times \theta_{\text{JA}})$. P_D : Power Dissipation, T_A : Ambient temperature, θ_{JA} : Thermal Resistance-Junction to Ambient The θ_{JA} numbers are guidelines for the thermal performance of the device/PC-board system. All of the above assume no ambient airflow.	

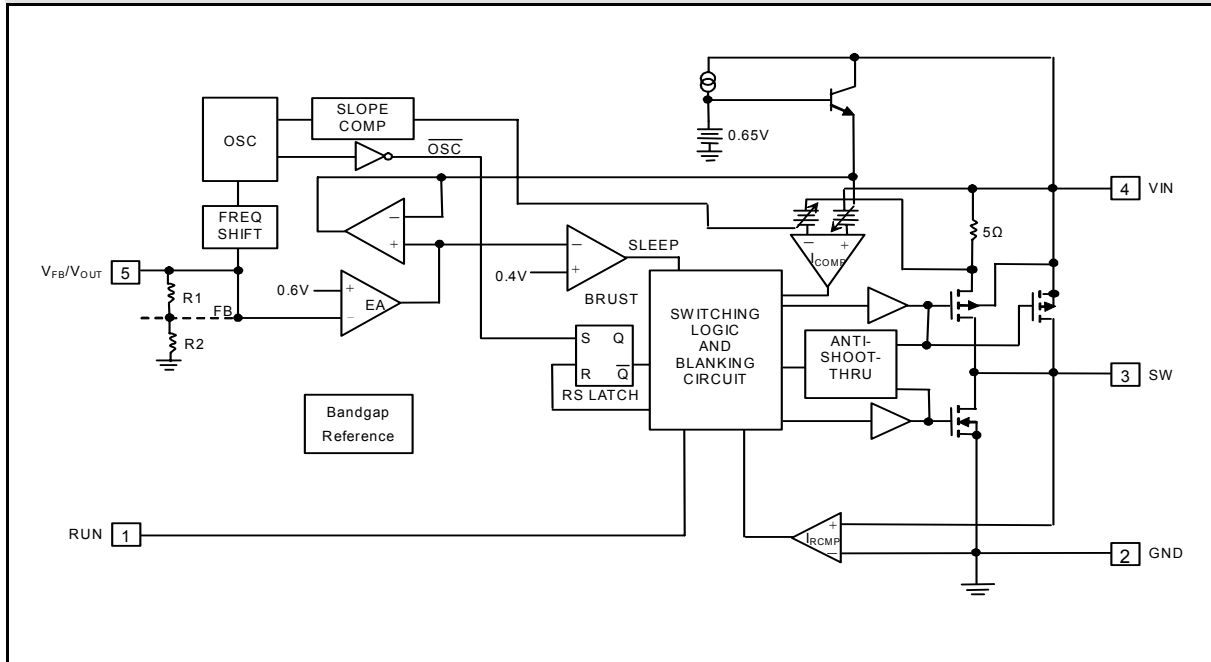
BLOCK DIAGRAM

ABSOLUTE MAXIMUM RATINGS (Note 1)

Input Voltage, V_{IN}	-0.3V to 6V
RUN, V_{FB} Voltage	-0.3V to V_{IN}
SW Voltage	-0.3 to $V_{IN}+0.3V$
P-Channel Switch Source Current (DC)	800mA
N-Channel Switch Sink Current (DC)	800mA
Peak SW Sink and Source Current	1.3A
Operating Temperature Range (Note 2)	-40°C to 85°C
Junction Temperature, T_J (Note 3)	125°C
Storage Temperature Range	-60°C to 150°C
Lead Temperature (soldering, 10 seconds)	300°C

Note 1: Absolute Maximum Ratings are those values beyond which the life of a device may be impaired.

Note 2: The AMC3100 is guaranteed to meet performance specifications from 0°C to 70°C. Specifications over the -40°C to 85°C operating temperature range are assured by design, characterization and correlation with statistical process controls.

Note 3: T_J is calculated from the ambient temperature T_A and power dissipation P_D according to the following formula:

$$T_J = T_A + (P_D \times \theta_{JA}).$$

RECOMMENDED OPERATING CONDITIONS

Parameter	Symbol	Min	Typ	Max	Unit
Supply Voltage	V_{IN}	2.5		5.5	V
Operating free-air temperature range	T_A	-40		85	°C

ELECTRICAL CHARACTERISTICS

$V_{IN}=3.6V, T_A=25^{\circ}C$. (Unless otherwise noted)						
Parameter	Symbol	Condition	Min	Typ	Max	Unit
Input DC Supply Current Active Mode	I_S	$V_{FB}=0.5V$ or $V_{OUT}=90\%$, $I_{LOAD}=0A$		300	400	μA
Shutdown		$V_{RUN}=0V, V_{IN}=4.2V$		0.1	1	
Regulated Output Voltage	V_{OUT}	AMC3100-1.8, $I_{OUT}=100mA$	1.746	1.800	1.854	V
		AMC3100-1.5, $I_{OUT}=100mA$	1.455	1.500	1.545	
		AMC3100-1.2, $I_{OUT}=100mA$	1.164	1.200	1.236	
Output Voltage Line Regulation	ΔV_{OUT}	$V_{IN}=2.5V$ to $5.5V$		0.04	0.4	%V
Output Voltage Load Regulation	V_{LDREG}			0.5		%
Peak Inductor Current	I_{PK}	Duty Cycle < 35%, $V_{IN}=3V$, $V_{FB}=0.5V$ or $V_{OUT}=90\%$,	0.75	1	1.25	A
Feedback Current	I_{VFB}				± 30	nA
Regulated Feedback Voltage	V_{FB}	$T_A=25^{\circ}C$	0.5880	0.6	0.6120	V
		$T_A=0^{\circ}C \leq T_A \leq 85^{\circ}C$	0.5865	0.6	0.6135	
		$T_A=-40^{\circ}C \leq T_A \leq 85^{\circ}C$	0.5850	0.6	0.6150	
Reference Voltage Line Regulation	ΔV_{FB}	$V_{IN}=2.5V$ to $5.5V$		0.04	0.4	%V
Oscillator Frequency	f_{OSC}	$V_{FB}=0.6V$ or $V_{OUT}=100\%$	1.2	1.5	1.8	MHz
$R_{DS(ON)}$ of P-Channel FET	R_{PFET}	$I_{SW}=100mA$		0.4	0.5	Ω
$R_{DS(ON)}$ of N-Channel FET	R_{NFET}	$I_{SW}=-100mA$		0.35	0.45	Ω
SW Leakage	I_{LSW}	$V_{RUN}=0V, V_{SW}=0V$ or $5V$, $V_{IN}=5V$		± 0.01	± 1	μA
RUN Threshold	V_{RUN}		0.3	1	1.5	V
RUN Leakage Current	I_{RUN}			± 0.01	± 1	μA

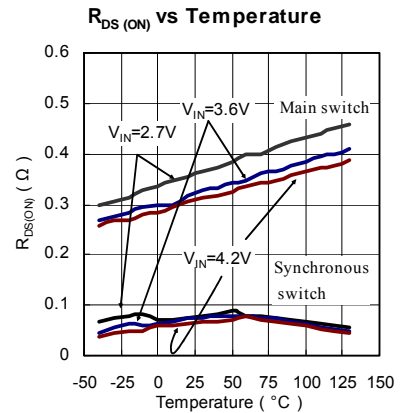
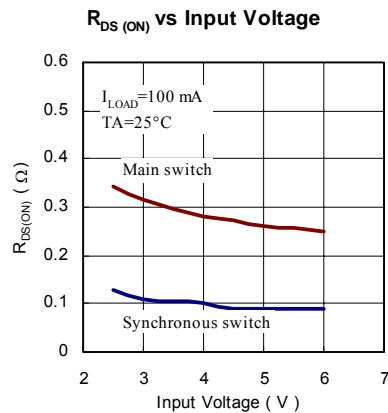
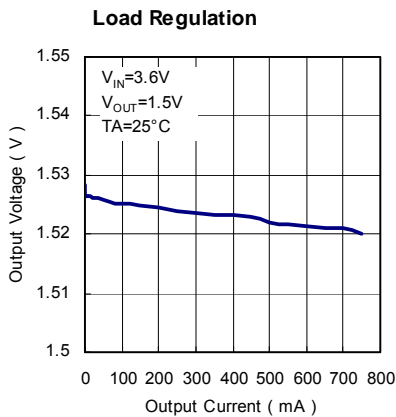
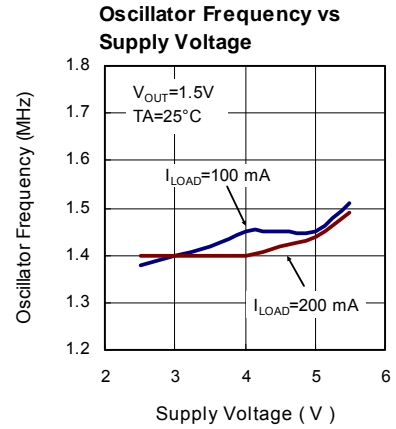
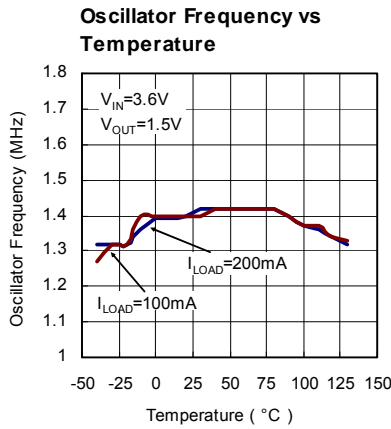
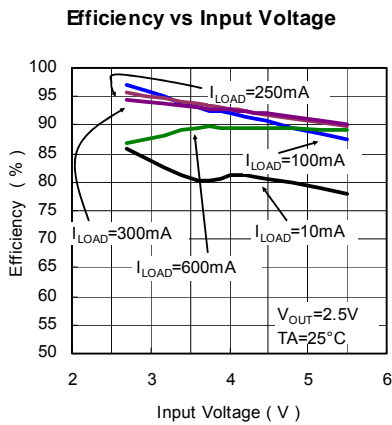
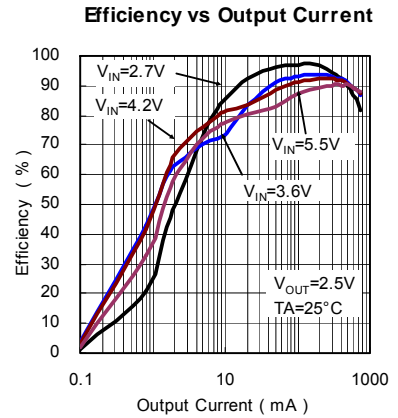
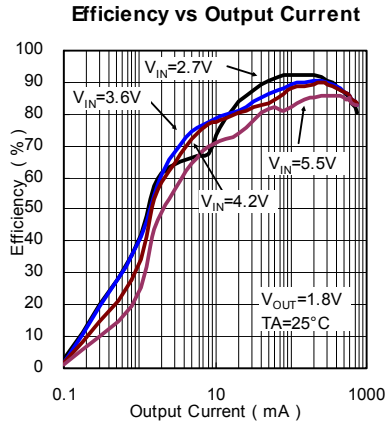
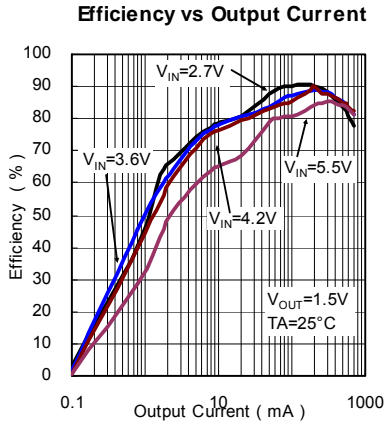
CHARACTERIZATION CURVES

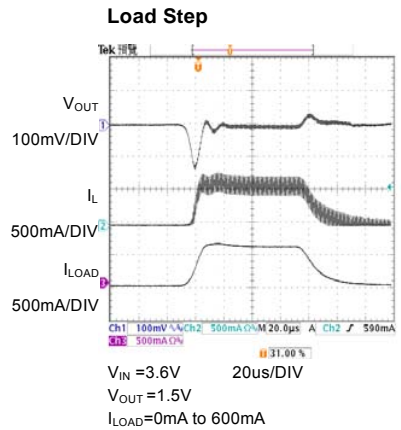
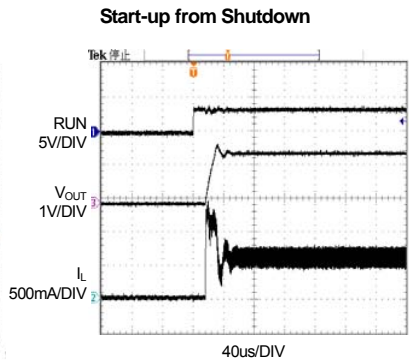
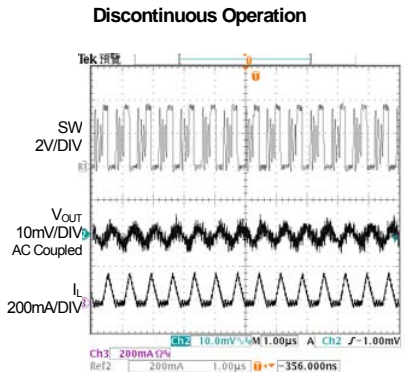
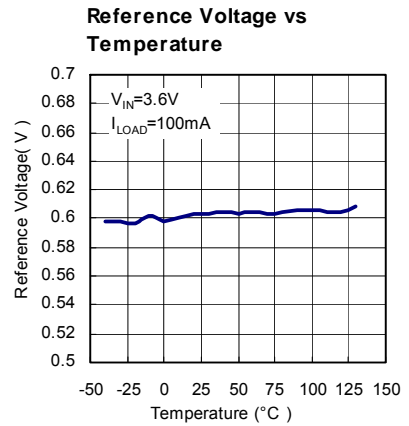
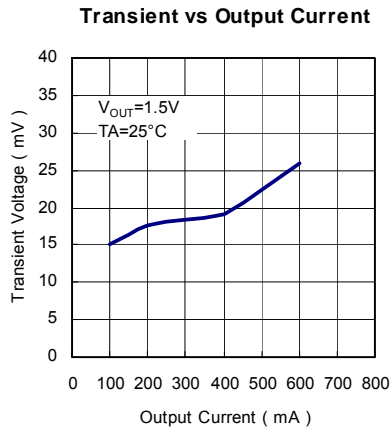
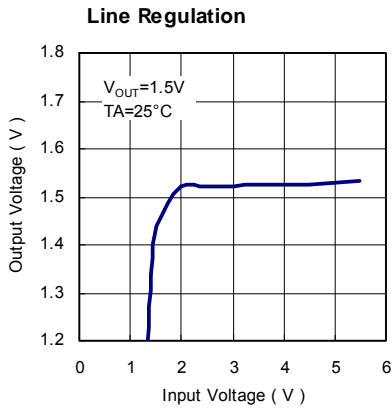
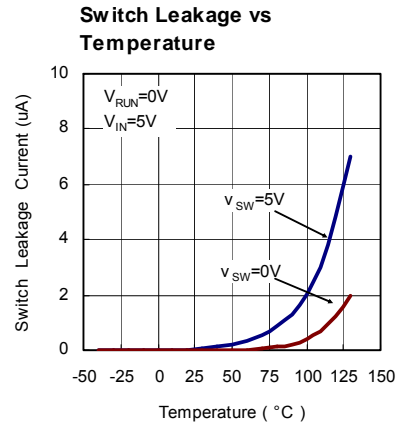
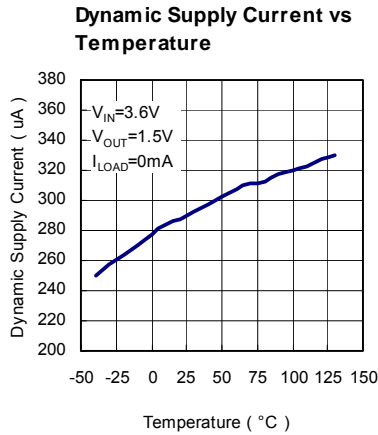
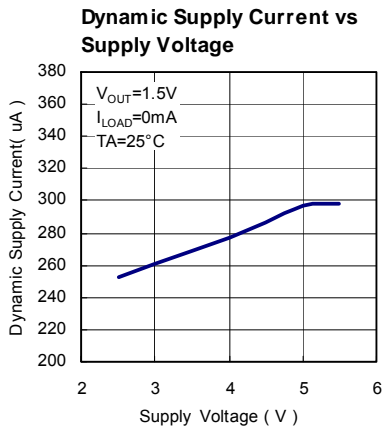

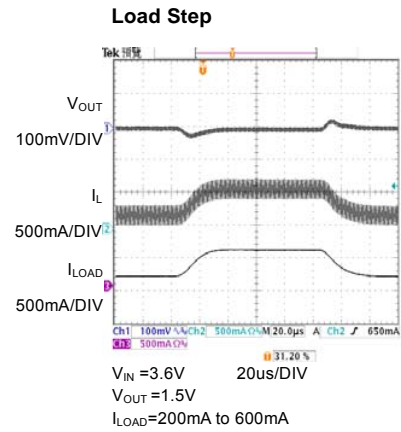
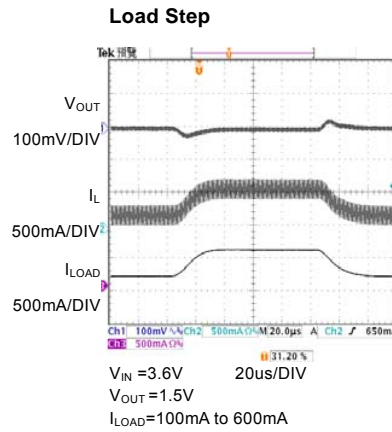
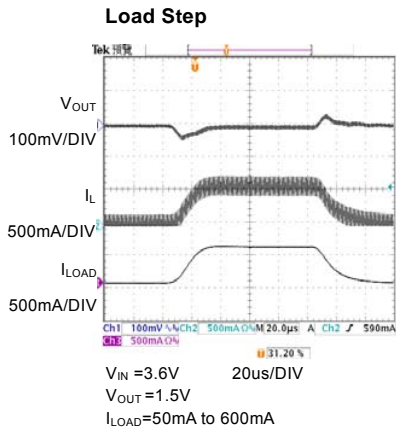

APPLICATION INFORMATION

The basic AMC3100 application circuit is shown in Figure 1. External component selection is driven by load requirement:

Adjustable Output Voltage:

In adjustable version, the output voltage is set by the below formula (1):

$$V_{OUT} = 0.6V \left(1 + \frac{R1}{R2} \right) \quad 0.6V \leq V_{OUT} \leq 5.5V \quad (1)$$

The external resistor divider sets the output voltage (see figure 1). Choose R1 around 1MΩ, R2 is then given by:

$$R2 = \frac{R1}{\left(\frac{V_{OUT}}{0.6V} - 1 \right)}$$

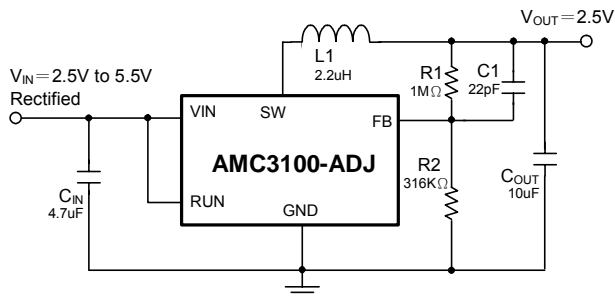

Figure 1

Table 1- Resistor Selection vs. Adjust Output Voltage.

V _{OUT}	R1	R2
1.2V	1MΩ, 1%	1MΩ, 1%
1.5V	1MΩ, 1%	667KΩ, 1%
1.8V	1MΩ, 1%	500KΩ, 1%
2.5V	1MΩ, 1%	316KΩ, 1%
3.3V	1MΩ, 1%	222KΩ, 1%

Inductor selection:

For most applications, the value of the inductor will fall in the range of 1uH to 4.7uH. Its value is chosen based on the desired ripple current. Large value inductors lower ripple current, and small value inductors result in higher ripple currents.

Higher V_{IN} or V_{OUT} also increases the ripple current as shown in the formula (2):

$$\Delta I_L = \frac{V_{OUT}}{fL} \left(1 - \frac{V_{OUT}}{V_{IN}} \right) \quad \text{Where, } f = \text{operating frequency, and } \Delta I_L = \text{ripple current in the inductor.} \quad (2)$$

C_{OUT} selection:

The output capacitor keeps output voltage ripple small and ensures regulation loop stable. The output capacitor impedance shall be low in switching frequency. The output ripple ΔV_{OUT} approximately:

$$\Delta V_{OUT} \cong \Delta I_L \left(ESR + \frac{1}{8fC_{OUT}} \right) \quad \text{Where, } C_{OUT} = \text{output capacitance.}$$

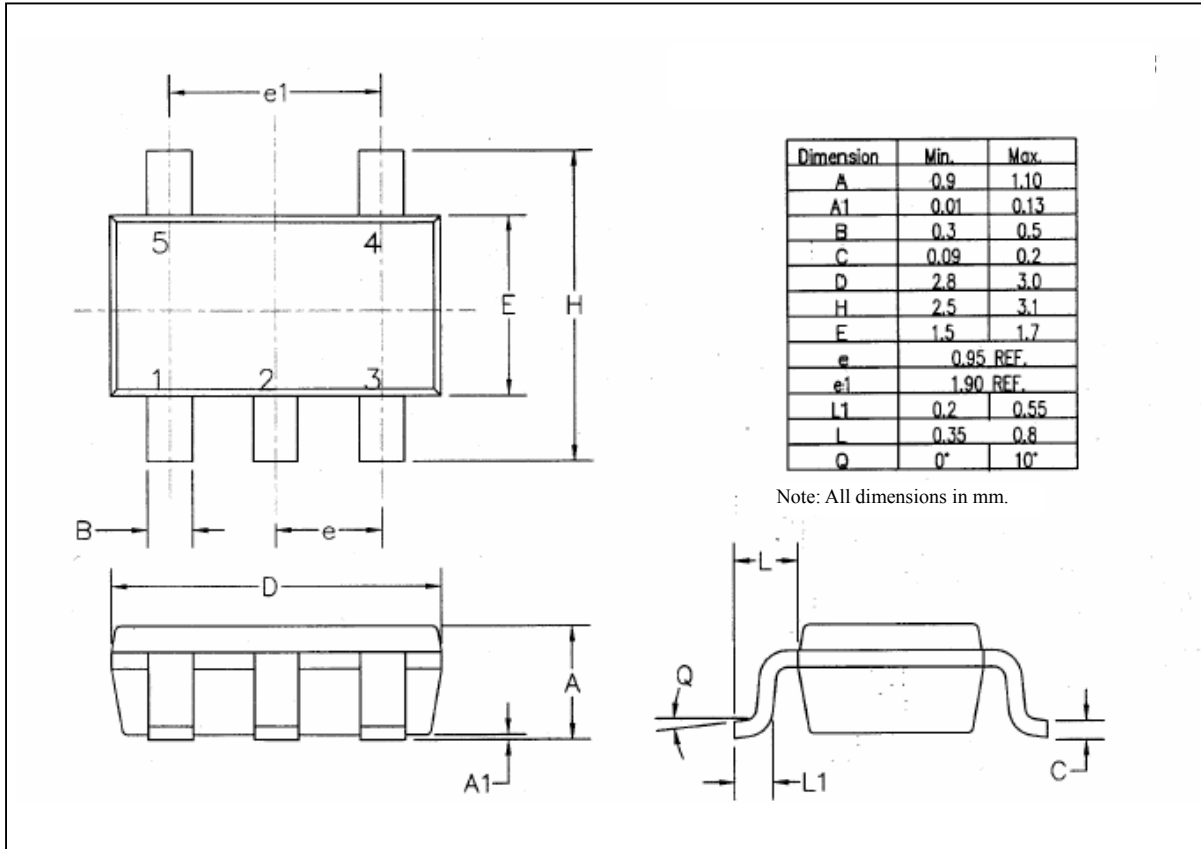
PACKAGE
TSOT-23-5L

IMPORTANT NOTICE

ADDtek reserves the right to make changes to its products or to discontinue any integrated circuit product or service without notice, and advises its customers to obtain the latest version of relevant information to verify, before placing orders, that the information being relied on is current.

A few applications using integrated circuit products may involve potential risks of death, personal injury, or severe property or environmental damage. ADDtek integrated circuit products are not designed, intended, authorized, or warranted to be suitable for use in life-support applications, devices or systems or other critical applications. Use of ADDtek products in such applications is understood to be fully at the risk of the customer. In order to minimize risks associated with the customer's applications, the customer should provide adequate design and operating safeguards.

ADDtek assumes no liability to customer product design or application support. ADDtek warrants the performance of its products to the specifications applicable at the time of sale.

ADDtek Corp.
9F, No. 20, Sec. 3, Bade Rd., Taipei, Taiwan, 105
TEL: 2-25700299
FAX: 2-25700196
