

Features

- **Depop Circuitry Integrated**
- **Thermal Shutdown Circuitry Integrated**
- **Output Power at 1% THD+N, $V_{DD}=5V$**
 - 1.8 W/Ch (typ) into a 4 W Load
 - 1.2 W/Ch (typ) into a 8 W Load
- **Bridge-Tied Load (BTL) or Single-Ended (SE) Modes Operation**
- **Various 24-Pin Power Packages Available**
SOP, TSSOP-P
- **Shutdown Control Mode , $I_{DD}=0.5\mu A$**
- **Lead Free and Green Devices Available (RoHS Compliant)**

Applications

- **Stereo Audio Power Amplifier for Notebook Computer**

General Description

The APA2020 is a stereo bridge-tied audio power amplifier in various 24-pin power packages, including SOP and TSSOP-P. When connecting to a 5V voltage supply, the APA2020 is capable of delivering 1.8W/1.2W of continuous RMS power per channel into 4Ω/8Ω loads with less than 1% THD+N, respectively. The APA2020 simplifies design and frees up board space for other features. The APA2020 also served well in low-voltage applications , which provides 800-mW per channel into 4Ω loads with a 3.3V supply voltage. Both of the depop circuitry and the thermal shutdown protection circuitry are integrated in the APA2020, that reduces pops and clicks noise during power up and when using the shutdown or mute modes and protects the chip from being destroyed by over-temperature failure.

To simplify the audio system design in notebook computer applications, the APA2020 combines a stereo bridge-tied loads (BTL) mode for speaker drive and a stereo single-end (SE) mode for headphone drive into a single chip, where both modes are easily switched by the SE/BTL input control pin signal. For power sensitive applications , the APA2020 also features a shutdown function which keeps the supply current only 0.5 μA (typ).

Pin Configuration

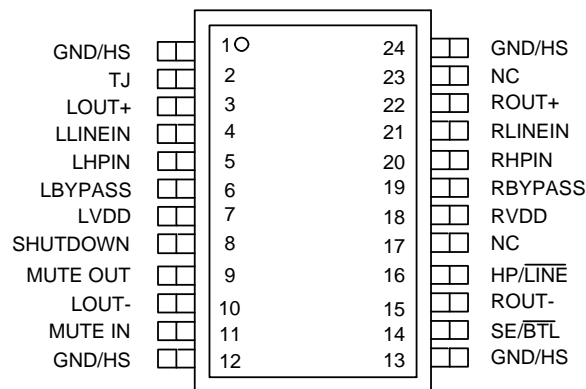

Top View

For SOP and TSSOP-P

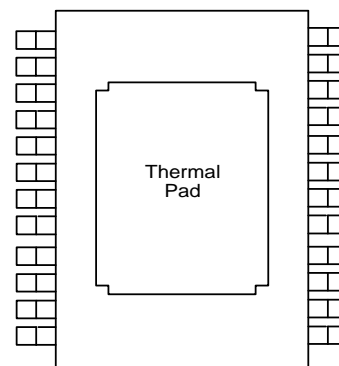



Bottom View

For TSSOP-P Only

ANPEC reserves the right to make changes to improve reliability or manufacturability without notice, and advise customers to obtain the latest version of relevant information to verify before placing orders.

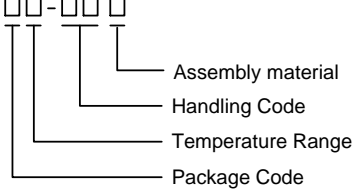
Ordering and Marking Information

| | |
|---|---|
| <p>APA2020 □□-□□□</p>  <p> Assembly material Handling Code Temperature Range Package Code </p> | <p>Package Code K : SOP-24 R : TSSOP-24P Operating Ambient Temperature Range I : - 40 to 85°C Handling Code TR : Tape & Reel Assembly material L : Lead Free Device G : Halogen and Lead Free Device</p> |
| <p>APA2020 K :  XXXXX - Date Code</p> | |
| <p>APA2020 R :  XXXXX - Date Code</p> | |

Note: ANPEC lead-free products contain molding compounds/die attach materials and 100% matte tin plate termination finish; which are fully compliant with RoHS. ANPEC lead-free products meet or exceed the lead-free requirements of IPC/JEDEC J-STD-020C for MSL classification at lead-free peak reflow temperature. ANPEC defines "Green" to mean lead-free (RoHS compliant) and halogen free (Br or Cl does not exceed 900ppm by weight in homogeneous material and total of Br and Cl does not exceed 1500ppm by weight).

Absolute Maximum Ratings

(Over operating free-air temperature range unless otherwise noted.)

| Symbol | Parameter | Rating | Unit |
|------------------|--|-------------|------|
| V _{DD} | Supply Voltage | 6 | V |
| T _A | Operating Ambient Temperature Range | -40 to 85 | °C |
| T _J | Maximum Junction Temperature | 150 | °C |
| T _{STG} | Maximum Lead Storage Temperature Range | -65 to +150 | °C |
| T _S | Maximum Lead Soldering Temperature, 10 Seconds | 260 | °C |

Recommended Operating Conditions

| Symbol | Parameter | | Min. | Typ. | Max. | Unit |
|------------------|--------------------------------|--|------|------|------|------|
| V _{DD} | Supply Voltage | | 3 | 5 | 5.5 | V |
| T _A | Operating free-air temperature | V _{DD} =5V, 4-Ω stereo BTL drive, 250mW/Ch average power, with proper PCB design | -20 | - | 85 | °C |
| | | V _{DD} =5V, 3-Ω stereo BTL drive, 2 W/Ch average power, with proper PCB design and 300 CFM forced-air cooling | -20 | - | 85 | |
| V _{ICM} | Common mode input voltage | V _{DD} =5 V | 1.25 | - | 4.5 | V |
| | | V _{DD} =3.3V | 1.25 | - | 2.7 | |

Thermal Characteristics

| Symbol | Parameter | Typical Value | Unit | |
|---------------|---|---------------|------|------|
| θ_{JA} | Thermal Resistance from Junction to Ambient in Free Air | SOP-24 | 65 | °C/W |
| | | TSSOP-24P | 45 | |

Electrical Characteristics

AC Operating Characteristics , $V_{DD}=5V$, $T_A=25^\circ C$, $R_L=4\Omega$ (unless otherwise noted)

| Symbol | Parameter | Test Conditions | APA2020 | | | Unit |
|-----------|---|---|---------|------------------|------|--------------|
| | | | Min. | Typ. | Max. | |
| P_O | Output Power (Each Channel) ^(Note 1) | THD+N = 10%, BTL $R_L=4\Omega$ $R_L=8\Omega$ | - | 2.3 1.5 | - | W |
| | | THD+N = 1%, BTL $R_L=4\Omega$ $R_L=8\Omega$ | - | 1.8 1.2 | - | |
| | | THD+N = 10%, SE $R_L=4\Omega$ $R_L=8\Omega$ | - | 650 400 | - | mW |
| | | THD+N = 1%, SE $R_L=4\Omega$ $R_L=8\Omega$ | - | 500 320 | - | |
| | | THD+N = 0.5%, SE $R_L=32\Omega$ | - | 90 | - | |
| THD + N | Total Harmonic Distortion Plus Noise | $P_O = 1.6W$, BTL $P_O = 1W$, BTL $P_O = 78mW$, SE $R_L=4\Omega$ $R_L=8\Omega$ $R_L=32\Omega$ | - | 300 150 20 | - | m% |
| | | $V_i = 1V$, $R_L = 4\Omega$, $A_V = 1$ | - | 10 | - | |
| BOM | Maximum Output Power Bandwidth | $A_V = 10$, THD+N < 1% | - | >20 | - | kHz |
| | Phase Margin | $R_L = 4\Omega$, BTL | - | 72 | - | ° |
| | | $R_L = 4\Omega$, Open Load | - | 71 | - | |
| | | $R_L = 4\Omega$, SE | - | 52 | - | |
| PSRR | Power Supply Ripple Rejection | $f = 100$ Hz | - | 80 | - | dB |
| | Mute Attenuation | | - | 85 | - | dB |
| Crosstalk | Channel-to-Channel Output Separation | | - | 85 | - | dB |
| HP/LINE | Input Separation | | - | 75 | - | dB |
| | BTL Attenuation in SE Mode | | - | 80 | - | dB |
| Z_i | Input Impedance | | - | 2 | - | M Ω |
| S/N | Signal-to-Noise Ratio | $P_O = 500$ mW, BTL | - | 90 | - | dB |
| V_n | Output Noise Voltage | | - | 80 | - | $\mu V(rms)$ |

Note 1 : Output power is measured at the output terminals of the IC at 1 kHz.

Electrical Characteristics (Cont.)

AC Operating Characteristics , $V_{DD} = 3.3V$, $T_A = 25^\circ C$, $R_L = 4\Omega$ (unless otherwise noted)

| Symbol | Parameter | Test Conditions | APA2020 | | | Unit |
|----------------|---|--|---------|------------------|------|---------|
| | | | Min. | Typ. | Max. | |
| P _O | Output Power (Each Channel) ^(Note 2) | THD+N = 10%, BTL R _L =4Ω R _L =8Ω | - | 1 0.6 | - | W |
| | | THD+N = 1%, BTL R _L =4Ω R _L =8Ω | - | 0.8 0.5 | - | |
| | | THD+N = 10%, SE R _L =4Ω R _L =8Ω | - | 290 180 | - | mW |
| | | THD+N = 1%, SE R _L =4Ω R _L =8Ω | - | 230 140 | - | |
| | | THD+N = 0.5%, SE R _L =32 Ω | - | 43 | - | |
| THD + N | Total Harmonic Distortion Plus Noise | P _O = 1.6W, BTL R _L =4Ω P _O = 1W, BTL R _L =8Ω P _O = 78mW, SE R _L =32Ω | - | 270 150 20 | - | m% |
| | | V _I = 1V, R _L =4Ω, A _V = 1 | - | 10 | - | |
| BOM | Maximum Output Power Bandwidth | A _V = 10, THD+N < 1% | - | >20 | - | kHz |
| | Phase Margin | R _L = 4Ω, BTL | - | 92 | - | ° |
| | | R _L = 4Ω, Open Load | - | 70 | - | |
| | | R _L = 4Ω, SE | - | 57 | - | |
| PSRR | Power Supply Ripple Rejection | f =100Hz | - | 70 | - | dB |
| | Mute Attenuation | | - | 85 | - | dB |
| Crosstalk | Channel-to-Channel Output Separation | f =1kHz | - | 85 | - | dB |
| HP/LINE | Input Separation | | - | 75 | - | dB |
| | BTL Attenuation in SE Mode | | - | 80 | - | dB |
| Z _i | Input Impedance | | - | 2 | - | MΩ |
| S/N | Signal-to-Noise Ratio | P _O = 500 mW, BTL | - | 90 | - | dB |
| V _n | Output Noise Voltage | | - | 50 | - | μV(rms) |

Note 2 : Output power is measured at the output terminals of the IC at 1 kHz.

DC Electrical Characteristic, T_A=25°C

| Symbol | Parameter | Test Conditions | APA2020 | | Unit | |
|-----------------------|--------------------------------|--|------------|------|------|----|
| | | | Typ. | Max. | | |
| I _{DD} | Supply Current | V _{DD} =5V | Stereo BTL | 8 | 11 | mA |
| | | | Stereo SE | 4 | 6.5 | mA |
| | | V _{DD} =3.3V | Stereo BTL | 7 | 9 | mA |
| | | | Stereo SE | 3.5 | 5.6 | mA |
| V _{OS} | DC Differential Output Voltage | V _{DD} =5V, A _V =2 ^(Note 3) | 5 | 25 | mV | |
| I _{DD(MUTE)} | Supply Current in Mute Mode | V _{DD} =5V | 8 | 11 | mA | |
| I _{SD} | Supply Current in Shutdown | V _{DD} =5V | 0.5 | 5 | μA | |

Note 3 : at 3V<V_{DD}<5V , the DC output voltage is approximately V_{DD} / 2.

Typical Operating Characteristics

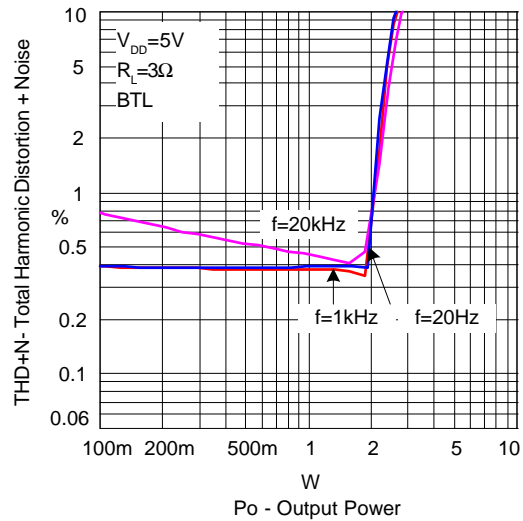
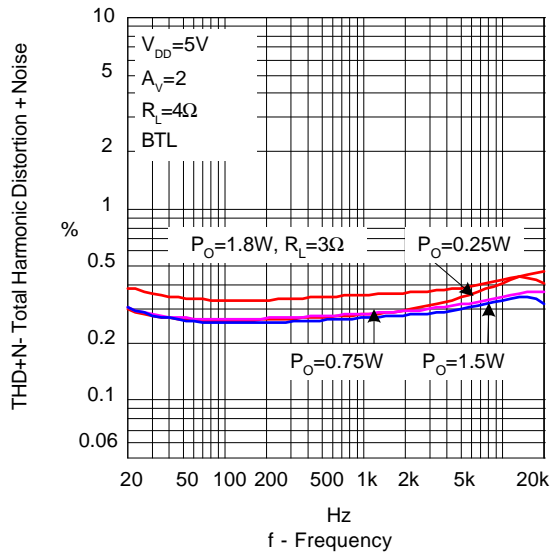
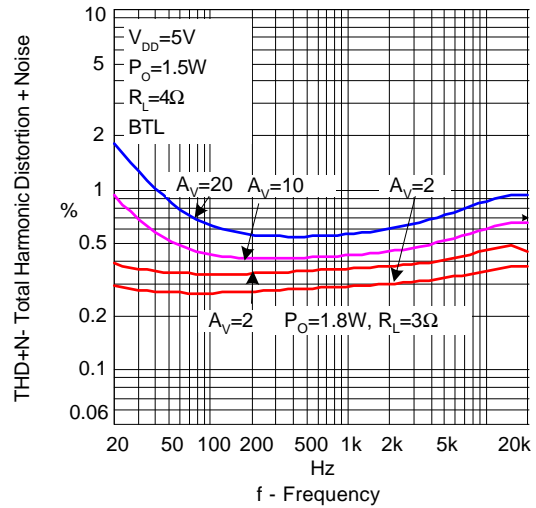
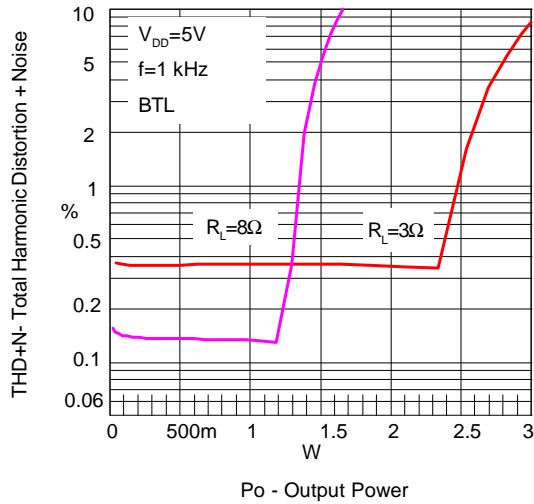

Typical Operating Characteristics (Cont.)

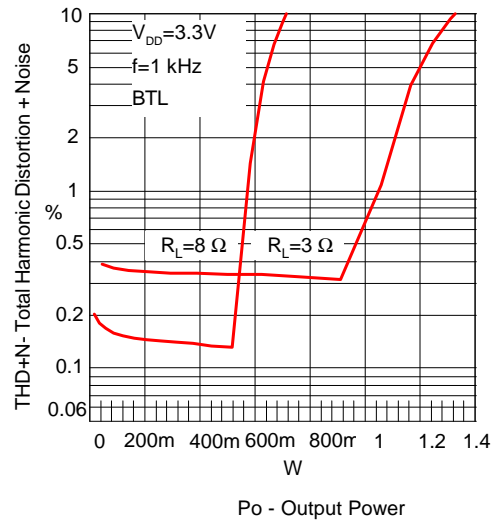
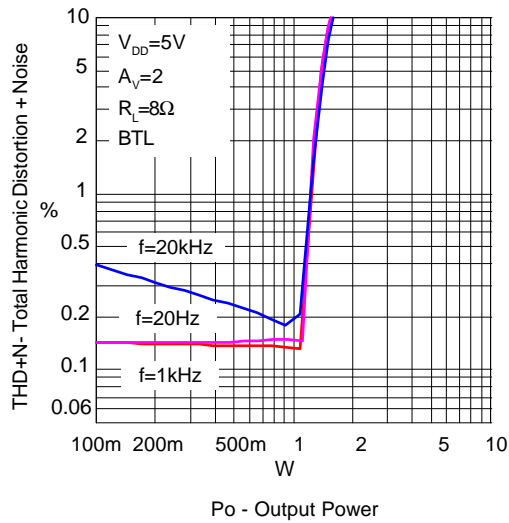
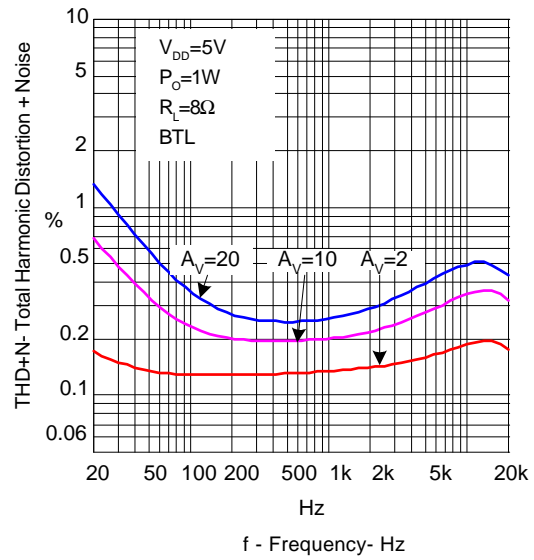
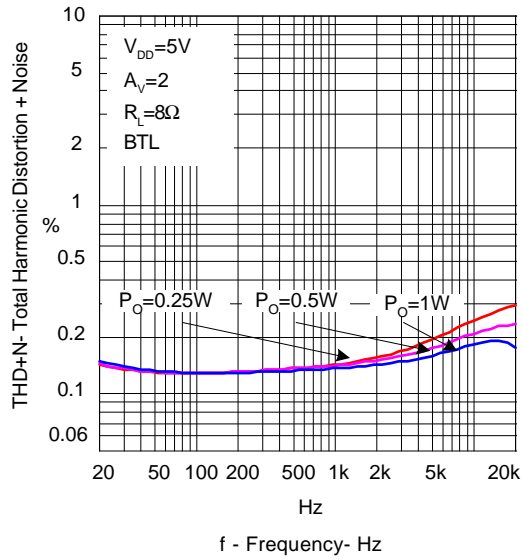

Typical Operating Characteristics (Cont.)

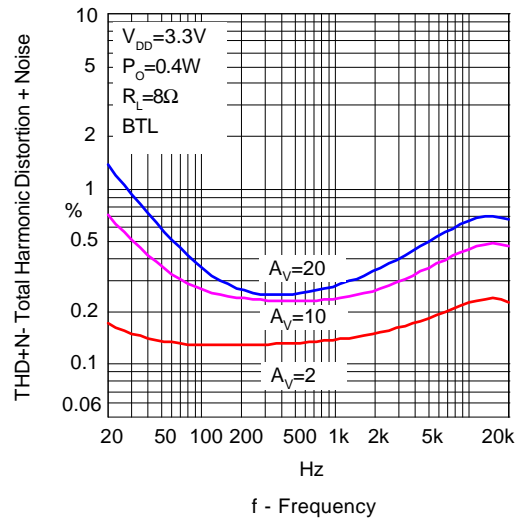
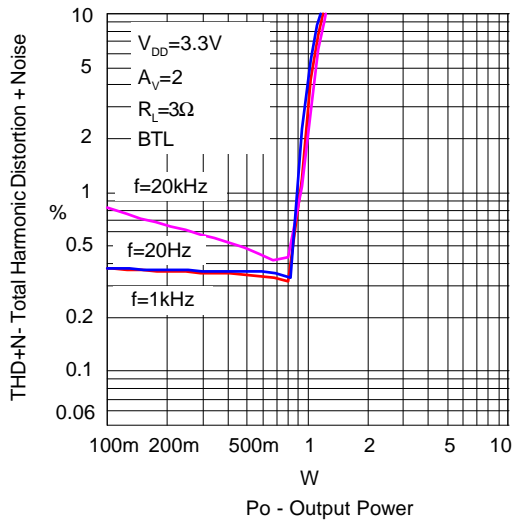
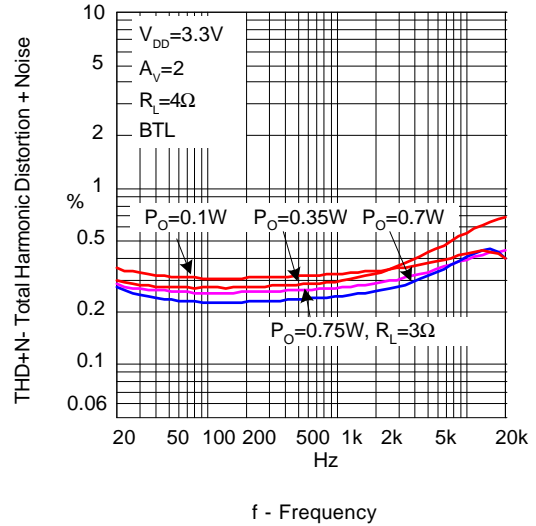
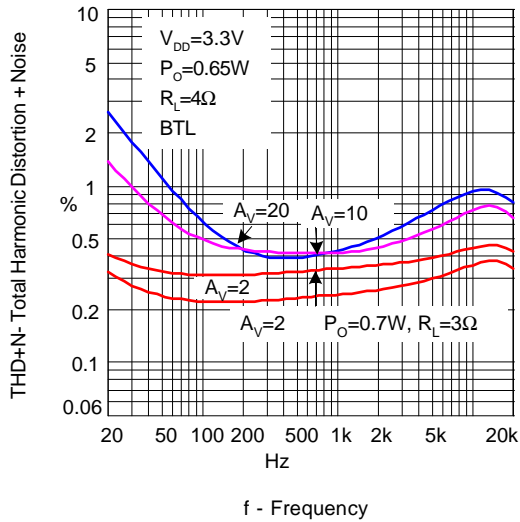

Typical Operating Characteristics (Cont.)

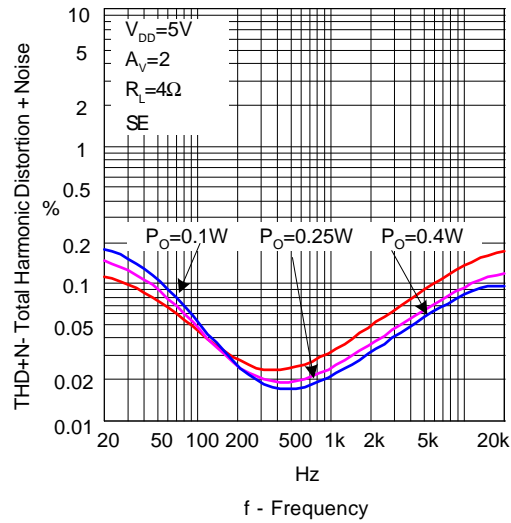
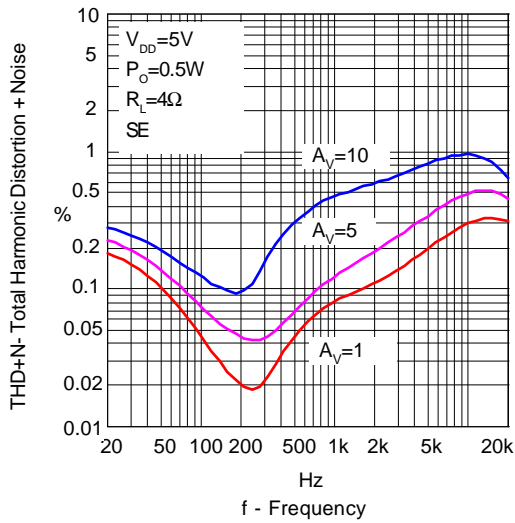
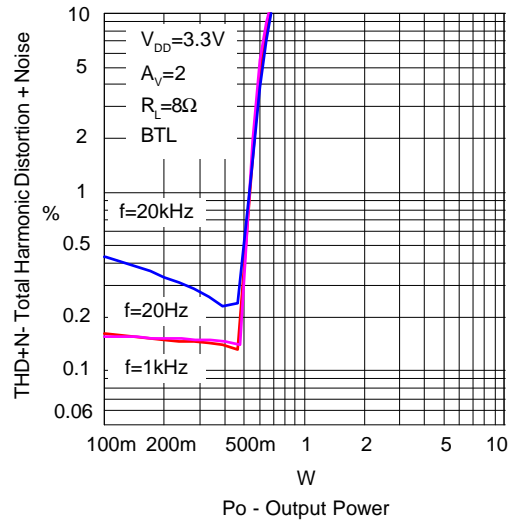
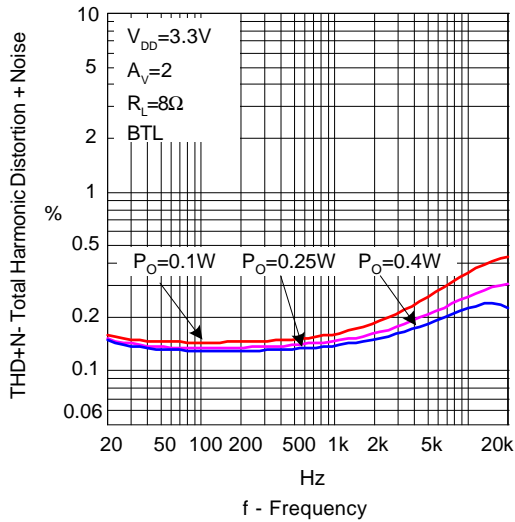

Typical Operating Characteristics (Cont.)

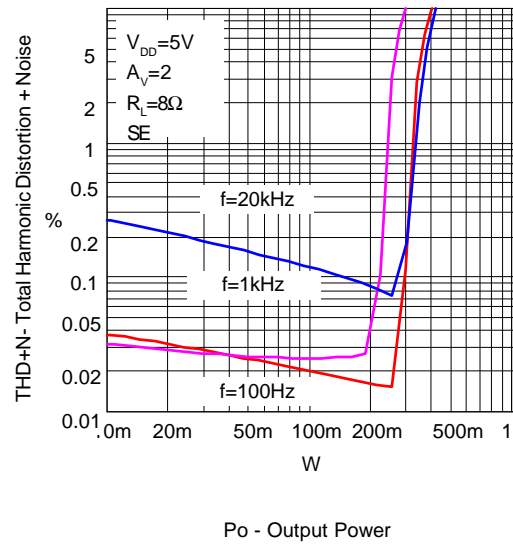
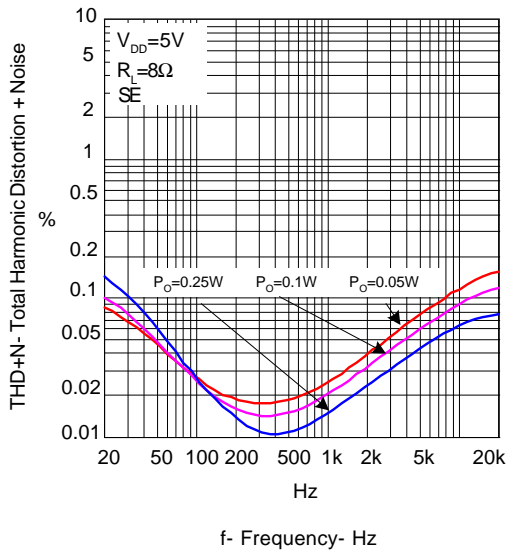
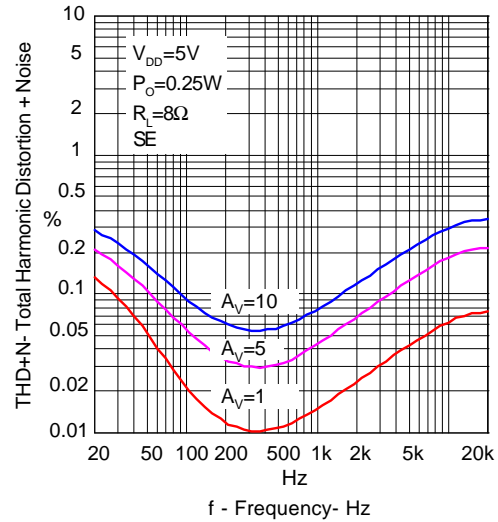
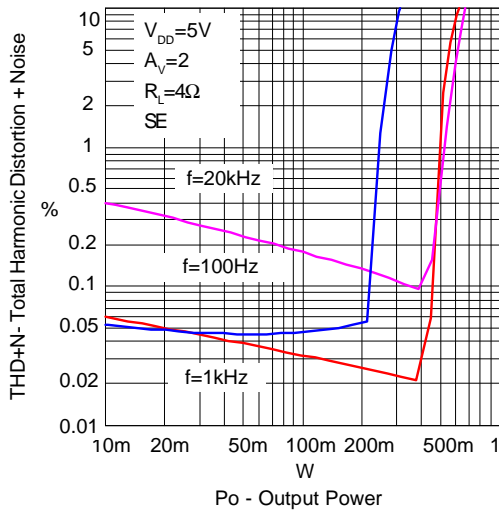

Typical Operating Characteristics (Cont.)

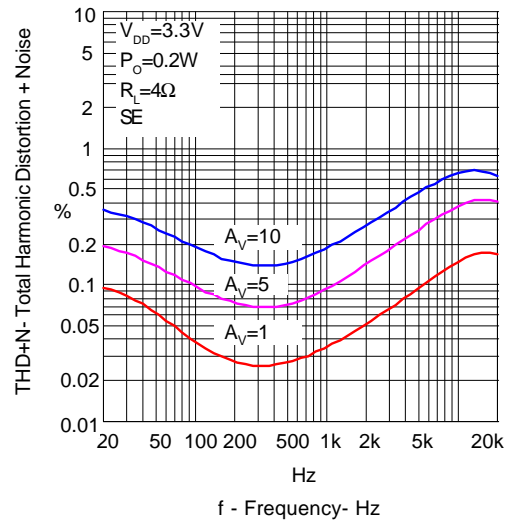
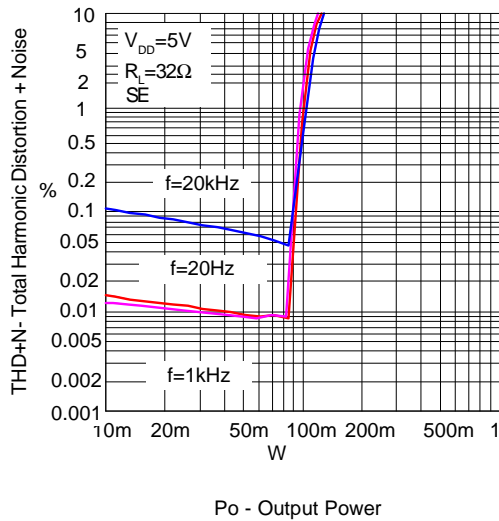
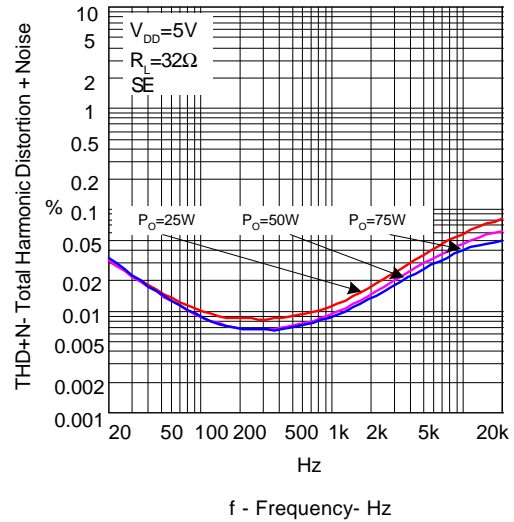
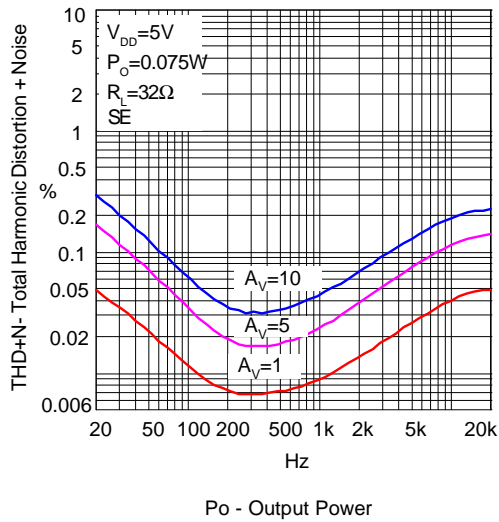

Typical Operating Characteristics (Cont.)

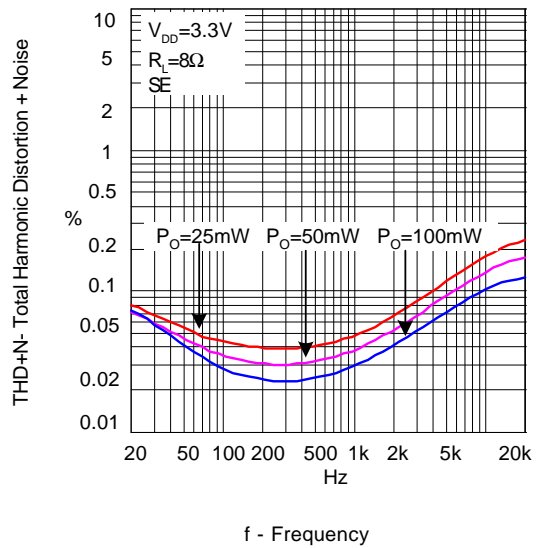
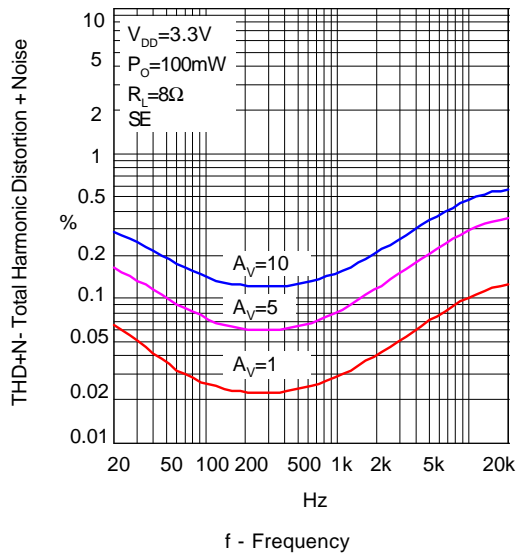
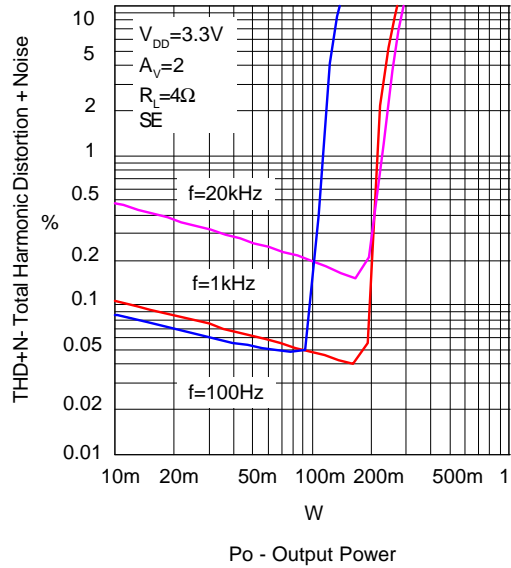
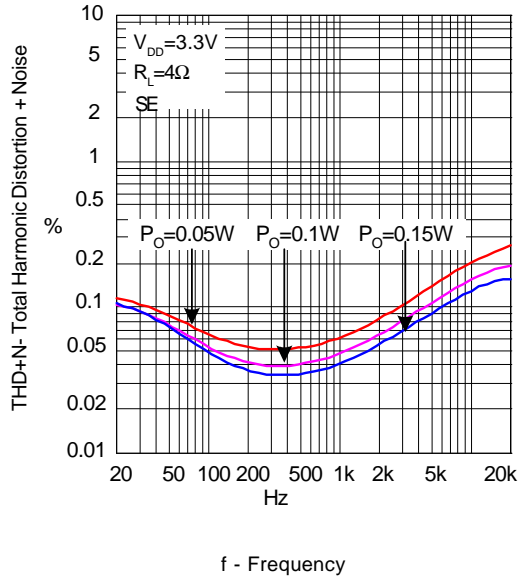

Typical Operating Characteristics (Cont.)

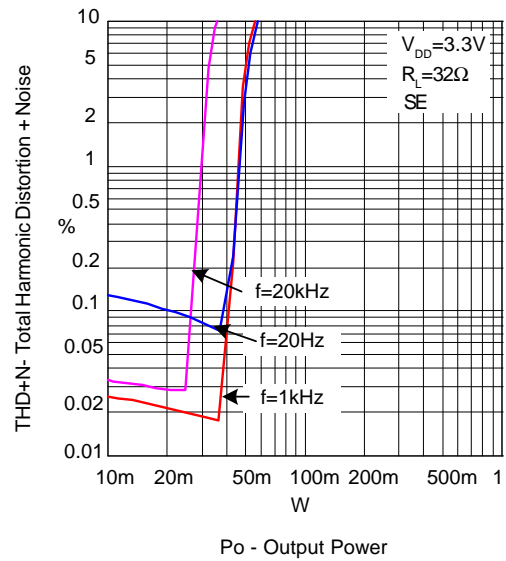
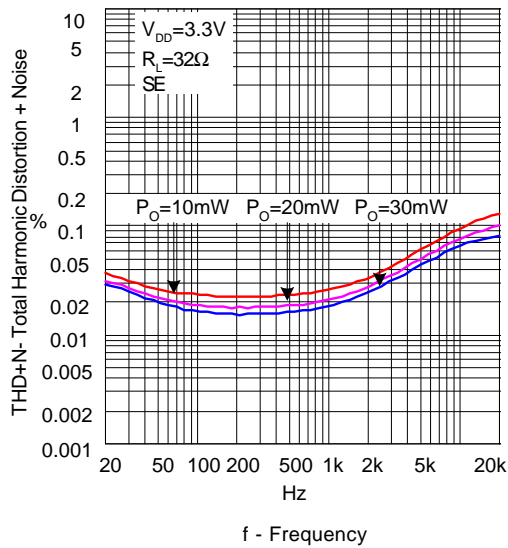
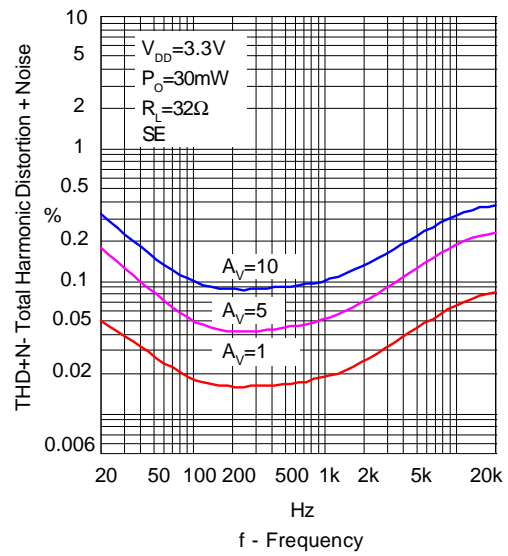
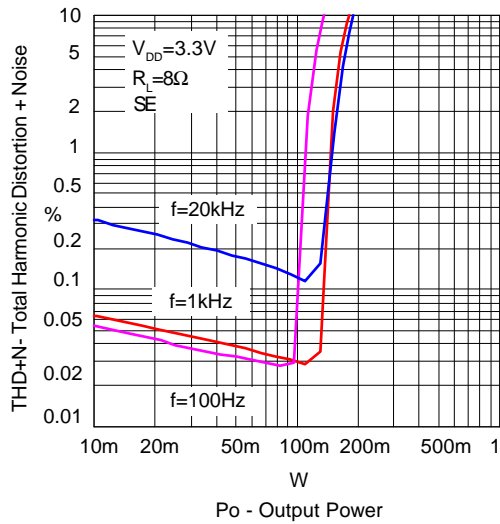

Typical Operating Characteristics (Cont.)

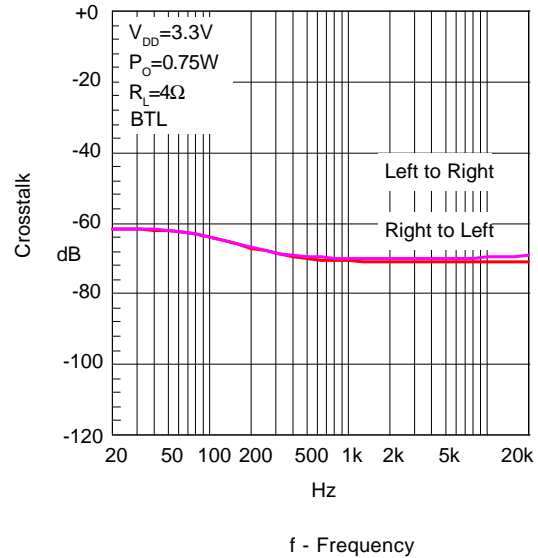
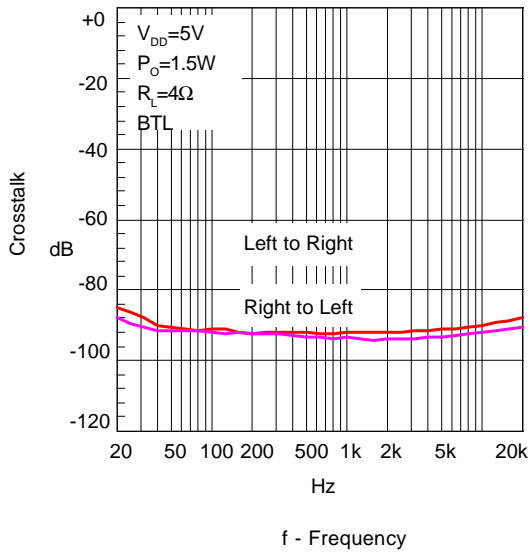
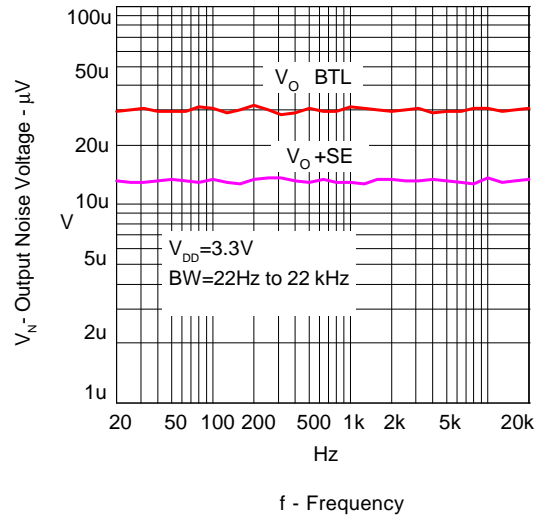
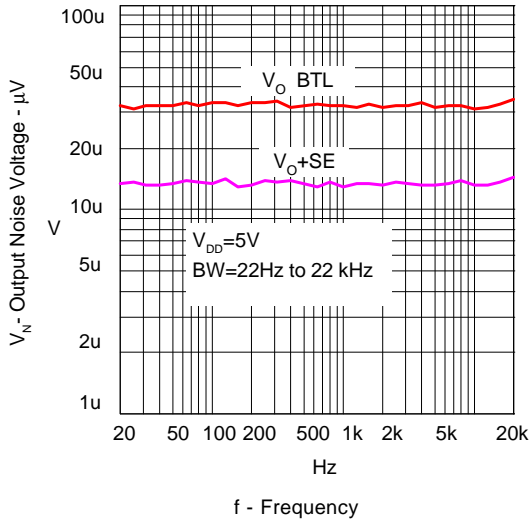

Typical Operating Characteristics (Cont.)

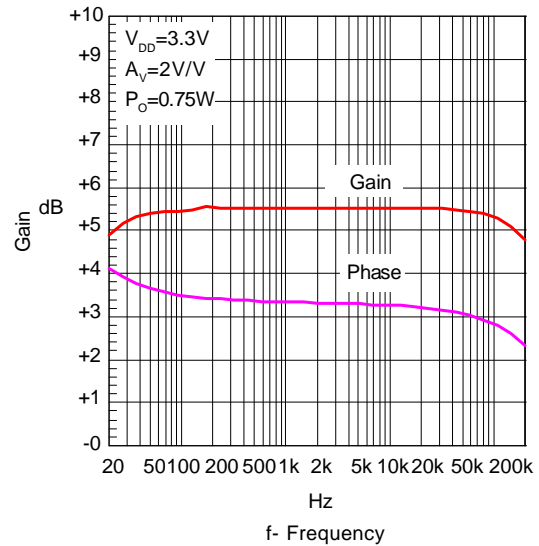
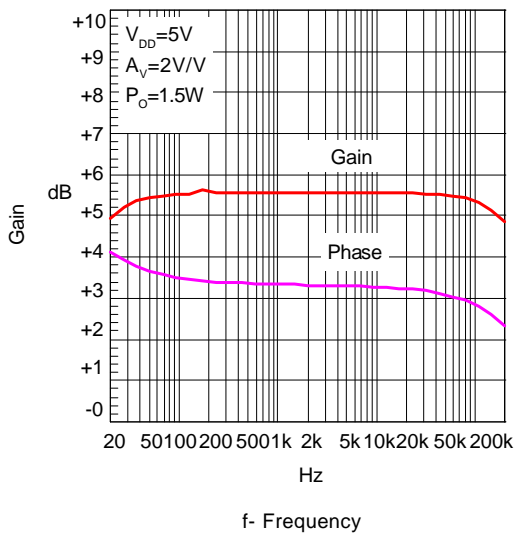
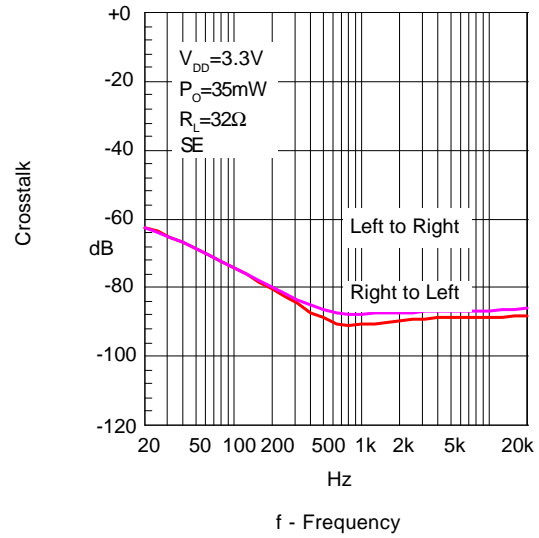
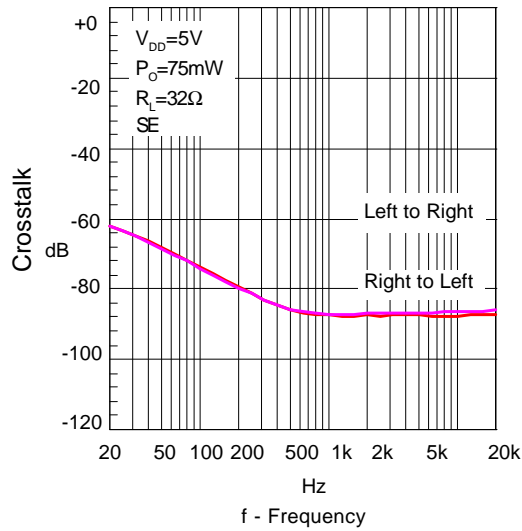

Typical Operating Characteristics (Cont.)

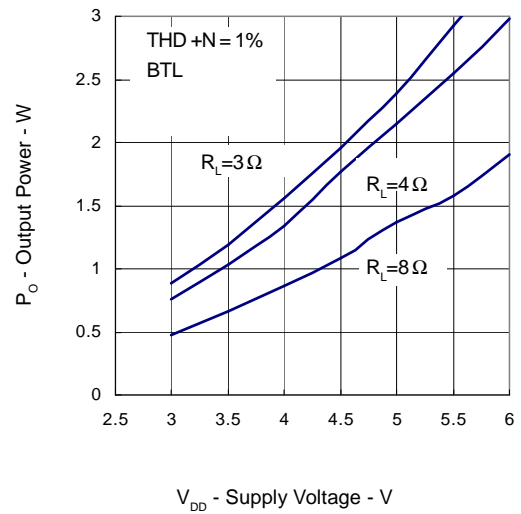
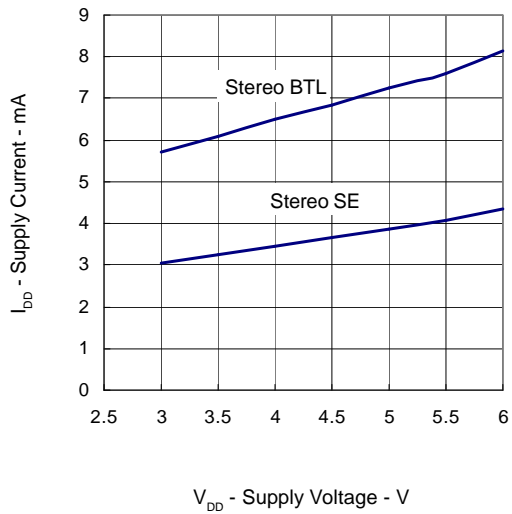
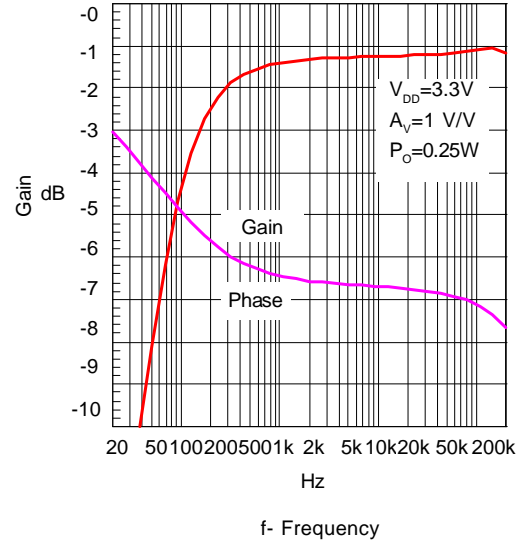
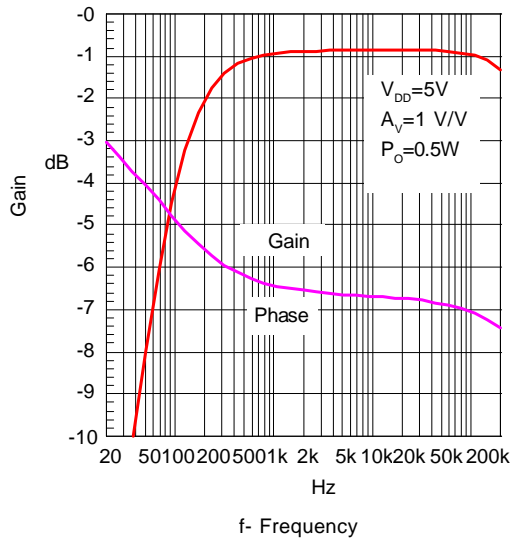

Typical Operating Characteristics (Cont.)

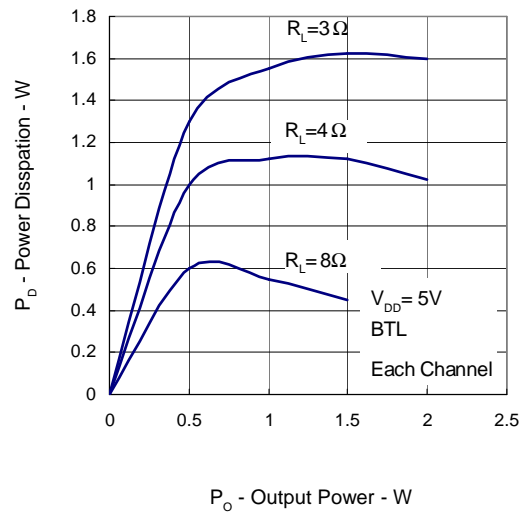
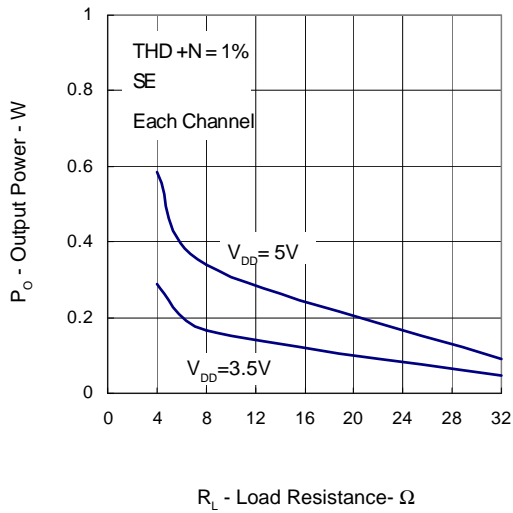
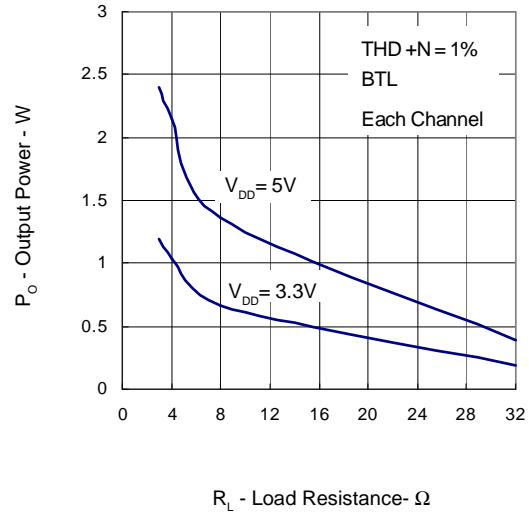
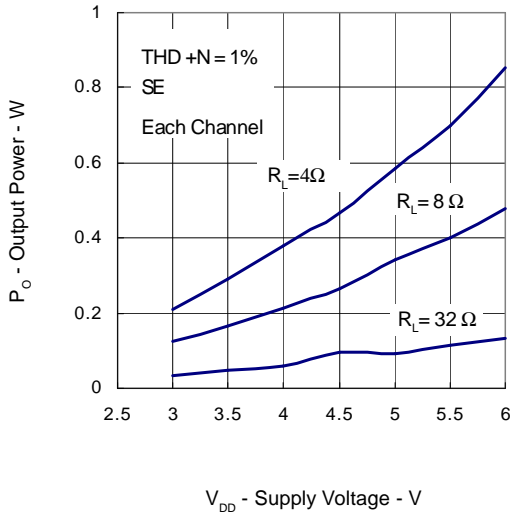

Typical Operating Characteristics (Cont.)

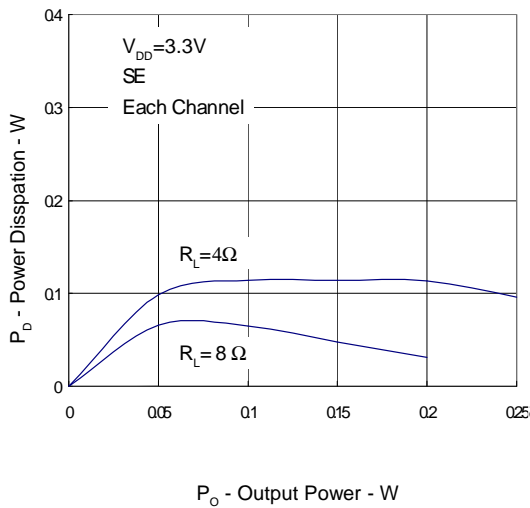
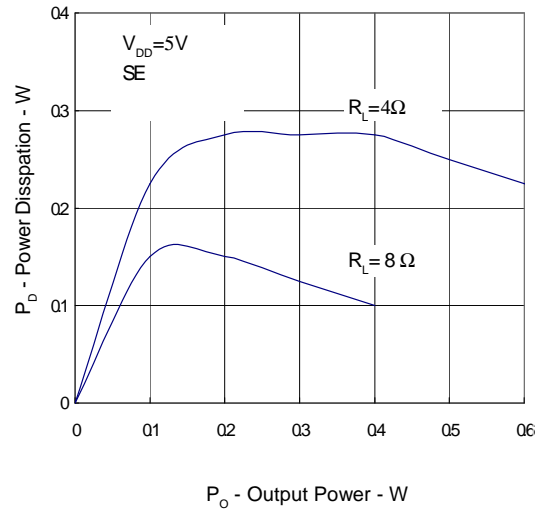
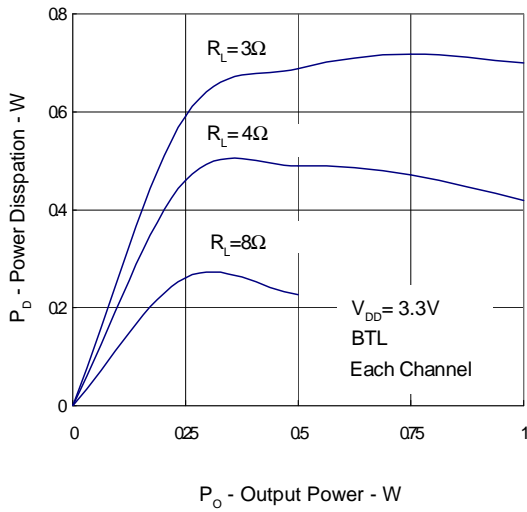

Pin Description

| PIN | | I/O | FUNCTION |
|----------|----------------|-----|---|
| NAME | NO. | | |
| GND/HS | 1,12, 13,24 | | Ground connection for circuitry, directly connected to thermal pad (only in TSSOP-P package). |
| TJ | 2 | O | Shutdown mode control signal input, sources a current proportional to the junction temperature. This pin should be left unconnected during normal operation. For more information, see the junction temperature measurement section of this document. |
| LOUT + | 3 | O | Left channel + output in BTL mode, + output in SE mode. |
| LLINEIN | 4 | I | Left channel line input, selected when HP/LINE pin (16) is held low. |
| LHPIN | 5 | I | Left channel headphone input, selected when HP/LINE pin (16) is held high. |
| LBYPASS | 6 | | Connect to voltage divider for left channel internal mid-supply bias. |
| LVDD | 7 | I | Supply voltage input for left channel and for primary bias circuits. |
| SHUTDOWN | 8 | I | Shutdown mode control signal input, places entire IC in shutdown mode when held high, $I_{SD} = 0.5\mu A$. |
| MUTE OUT | 9 | O | Follows MUTE in pin (11), provides buffered output. |
| LOUT - | 10 | O | Left channel - output in BTL mode, high-impedance state in SE mode. |
| MUTE IN | 11 | I | Mute control signal input, hold low for normal operation, hold high to mute. |
| SE/BTL | 14 | I | Mode control signal input, hold low for BTL mode, hold high for SE mode. |
| ROUT- | 15 | O | Right channel - output in BTL mode, high impedance state in SE mode. |
| HP/LINE | 16 | I | MUX control input, hold high to select headphone inputs (5,20), hold low to select line inputs (4,21). |
| NC | 17,23 | | No internal connection. |
| RVDD | 18 | I | Supply voltage input for right channel. |
| RBYPASS | 19 | | Connect to voltage divider for right channel internal mid-supply bias. |
| RHPIN | 20 | I | Right channel headphone input, selected when HP/LINE pin (16) is held high. |
| RLINEIN | 21 | I | Right channel line input, selected when HP/LINE pin (16) is held low. |
| ROUT+ | 22 | O | Right channel + output in BTL mode, + output in SE mode. |

Test Information

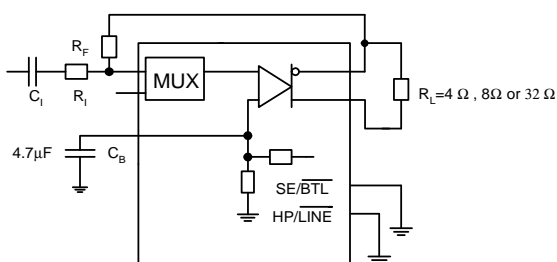

Figure 1. BTL Test Circuit

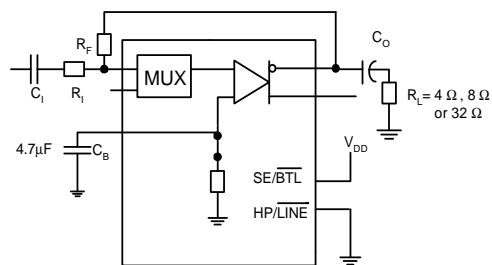

Figure 2. SE Test Circuit

Block Diagram

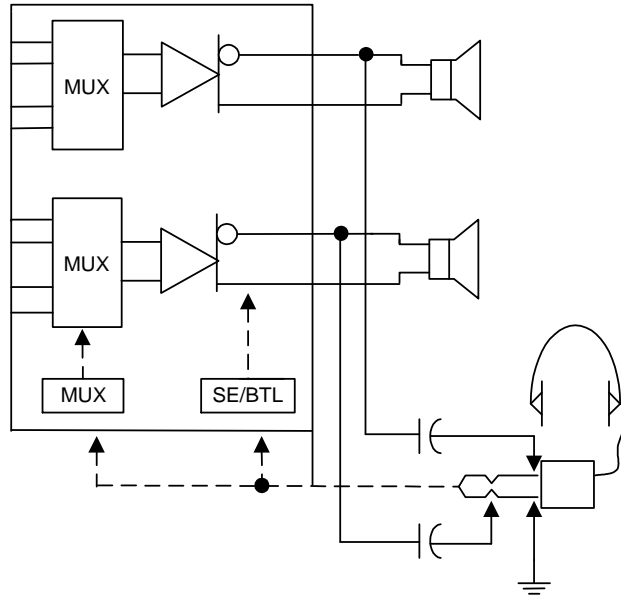
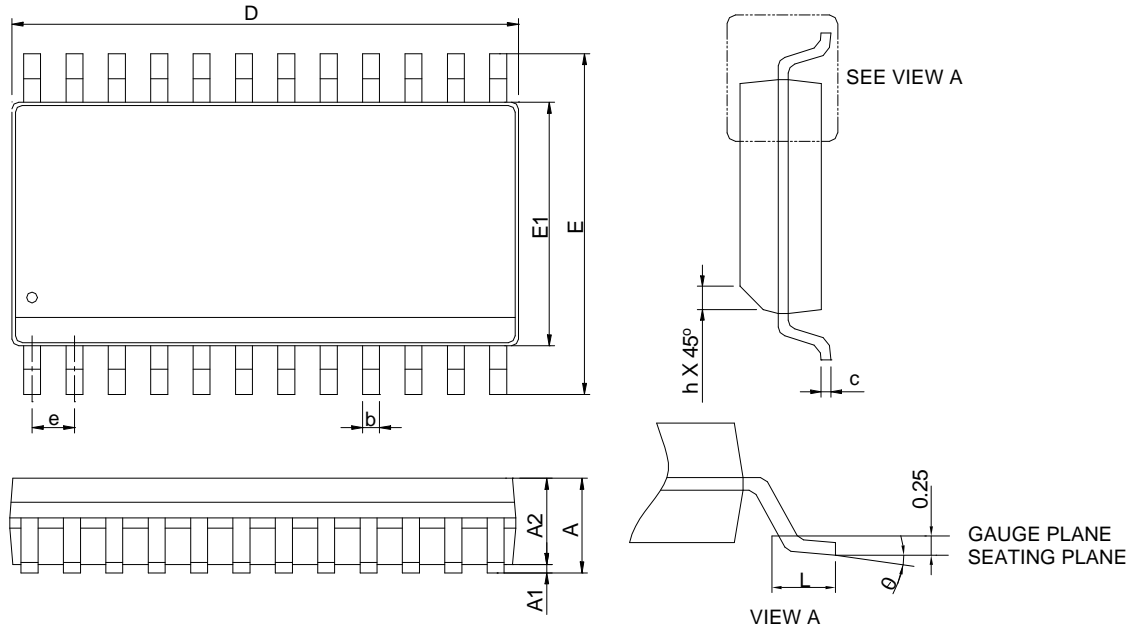

Figure 3.

Package Information

SOP-24



| SYMBOL | SOP-24 | | | |
|----------|-------------|-------|-----------|-------|
| | MILLIMETERS | | INCHES | |
| | MIN. | MAX. | MIN. | MAX. |
| A | | 2.65 | | 0.104 |
| A1 | 0.10 | 0.30 | 0.004 | 0.012 |
| A2 | 2.05 | | 0.081 | |
| b | 0.31 | 0.51 | 0.012 | 0.020 |
| c | 0.20 | 0.33 | 0.008 | 0.013 |
| D | 15.20 | 15.60 | 0.598 | 0.614 |
| E | 10.10 | 10.50 | 0.398 | 0.413 |
| E1 | 7.40 | 7.60 | 0.291 | 0.299 |
| e | 1.27 BSC | | 0.050 BSC | |
| h | 0.25 | 0.75 | 0.010 | 0.030 |
| L | 0.40 | 1.27 | 0.016 | 0.050 |
| θ | 0° | 8° | 0° | 8° |

- Note : 1. Follow from JEDEC MS-013 AD.
 2. Dimension "D" does not include mold flash, protrusions or gate burrs. Mold flash, protrusion or gate burrs shall not exceed 6 mil per side.
 3. Dimension "E" does not include inter-lead flash or protrusions. Inter-lead flash and protrusions shall not exceed 10 mil per side.

Package Information

TSSOP-24P

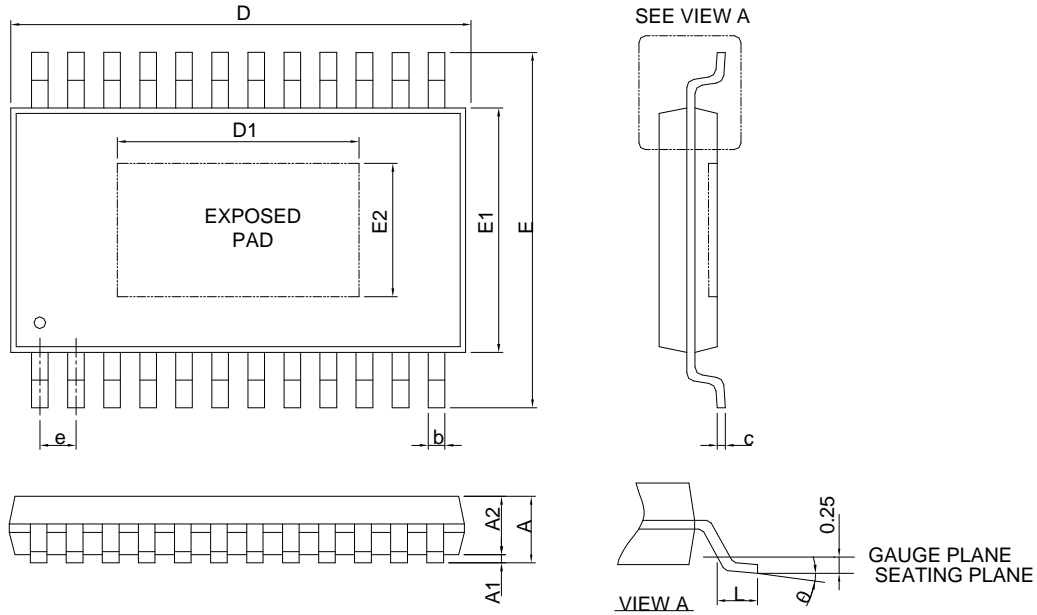

| SYMBOL | TSSOP-24P | | | |
|--------|-------------|------|-----------|-------|
| | MILLIMETERS | | INCHES | |
| | MIN. | MAX. | MIN. | MAX. |
| A | | 1.20 | | 0.047 |
| A1 | 0.05 | 0.15 | 0.002 | 0.006 |
| A2 | 0.80 | 1.05 | 0.031 | 0.041 |
| b | 0.19 | 0.30 | 0.007 | 0.012 |
| c | 0.09 | 0.20 | 0.004 | 0.008 |
| D | 7.70 | 7.9 | 0.303 | 0.311 |
| D1 | 3.50 | 6.00 | 0.138 | 0.197 |
| E | 6.20 | 6.60 | 0.244 | 0.260 |
| E1 | 4.30 | 4.50 | 0.169 | 0.177 |
| E2 | 2.50 | 3.50 | 0.098 | 0.138 |
| e | 0.65 BSC | | 0.026 BSC | |
| L | 0.45 | 0.75 | 0.018 | 0.030 |
| θ | 0° | 8° | 0° | 8° |

- Note : 1. Followed from JEDEC MO-153 ADT.
 2. Dimension "D" does not include mold flash, protrusions or gate burrs. Mold flash, protrusion or gate burrs shall not exceed 6 mil per side.
 3. Dimension "E1" does not include inter-lead flash or protrusions. Inter-lead flash and protrusions shall not exceed 10 mil per side.

Carrier Tape & Reel Dimensions

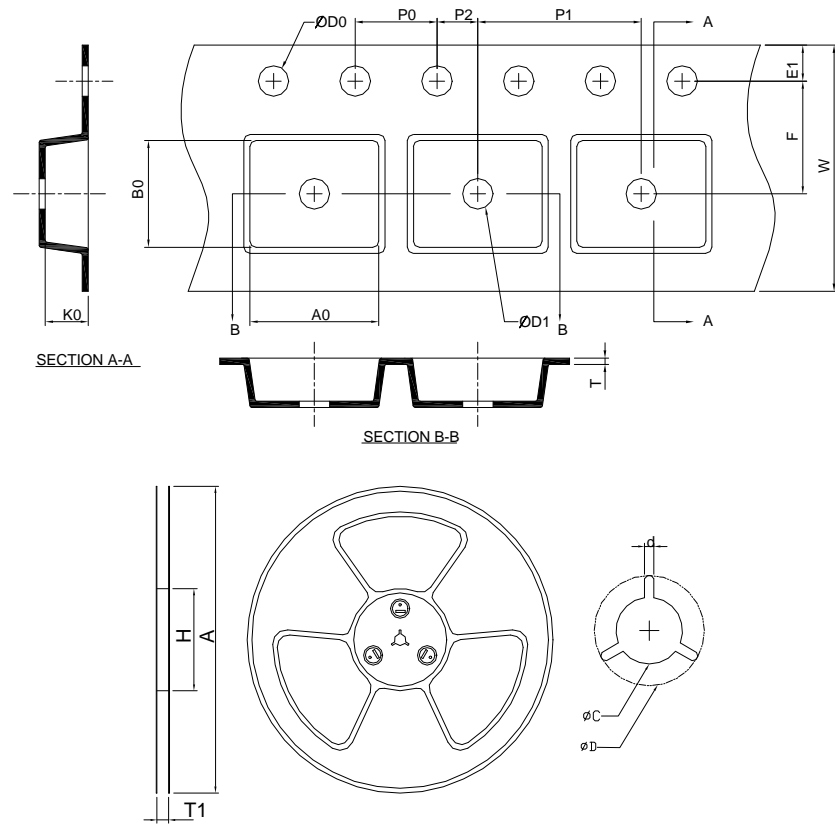

| Application | A | H | T1 | C | d | D | W | E1 | F |
|-------------|-------------|------------|--------------------|--------------------|----------|-------------------|------------|-------------|------------|
| SOP-24 | 330.0 ±2.00 | 50 MIN. | 24.4+2.0 -0.00 | 13.0+0.50 -0.20 | 1.5 MIN. | 20.2 MIN. | 24.0 ±0.30 | 1.75 ±0.10 | 11.5 ±0.10 |
| | P0 | P1 | P2 | D0 | D1 | T | A0 | B0 | K0 |
| | 4.0 ±0.10 | 12.0 ±0.10 | 2.0 ±0.10 | 1.5+0.10 -0.00 | 1.5 MIN. | 0.6+0.00 -0.40 | 10.9 ±0.20 | 15.80 ±0.20 | 3.10 ±0.20 |
| Application | A | H | T1 | C | d | D | W | E1 | F |
| TSSOP-24P | 330.0 ±2.00 | 50 MIN. | 16.4+2.00 -0.00 | 13.0+0.50 -0.20 | 1.5 MIN. | 20.2 MIN. | 16.0 ±0.30 | 1.75 ±0.10 | 7.50 ±0.10 |
| | P0 | P1 | P2 | D0 | D1 | T | A0 | B0 | K0 |
| | 4.00 ±0.10 | 8.00 ±0.10 | 2.00 ±0.10 | 1.5+0.10 -0.00 | 1.5 MIN. | 0.6+0.00 -0.40 | 6.9 ±0.20 | 8.30 ±0.20 | 1.50 ±0.20 |

(mm)

Devices Per Unit

| Package Type | Unit | Quantity |
|--------------|-------------|----------|
| SOP-24 | Tape & Reel | 1000 |
| TSSOP-24P | Tape & Reel | 2000 |

Taping Direction Information

SOP-24

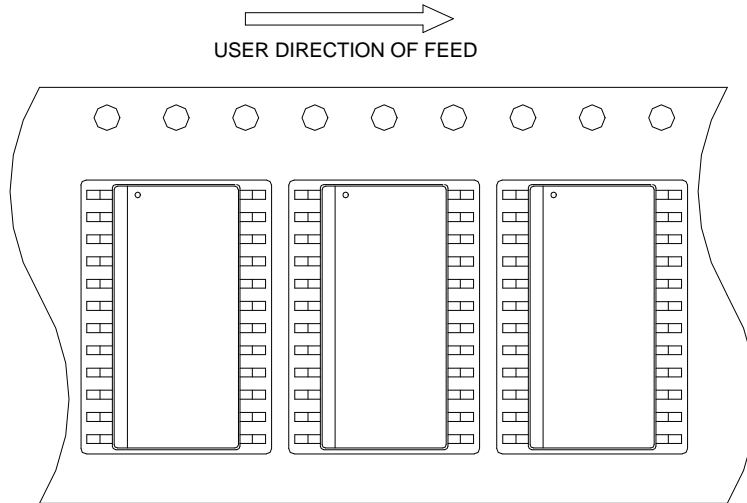

TSSOP-24P

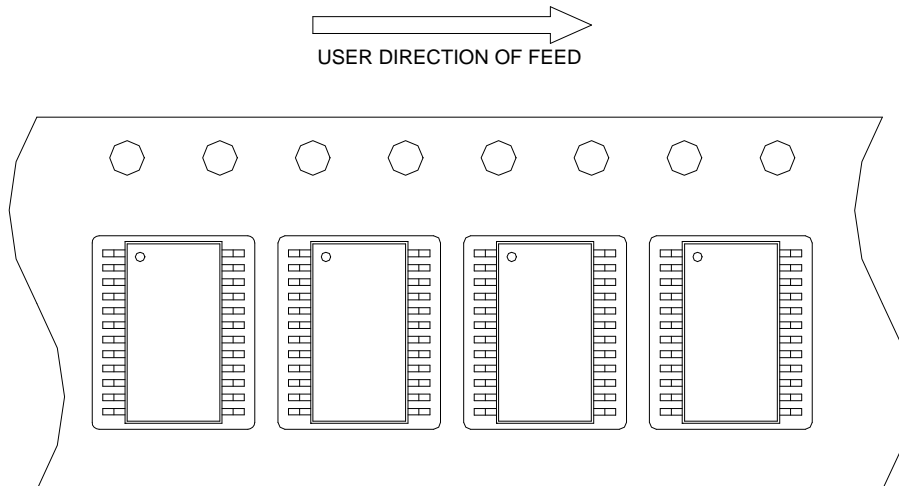

Reflow Condition (IR/Convection or VPR Reflow)

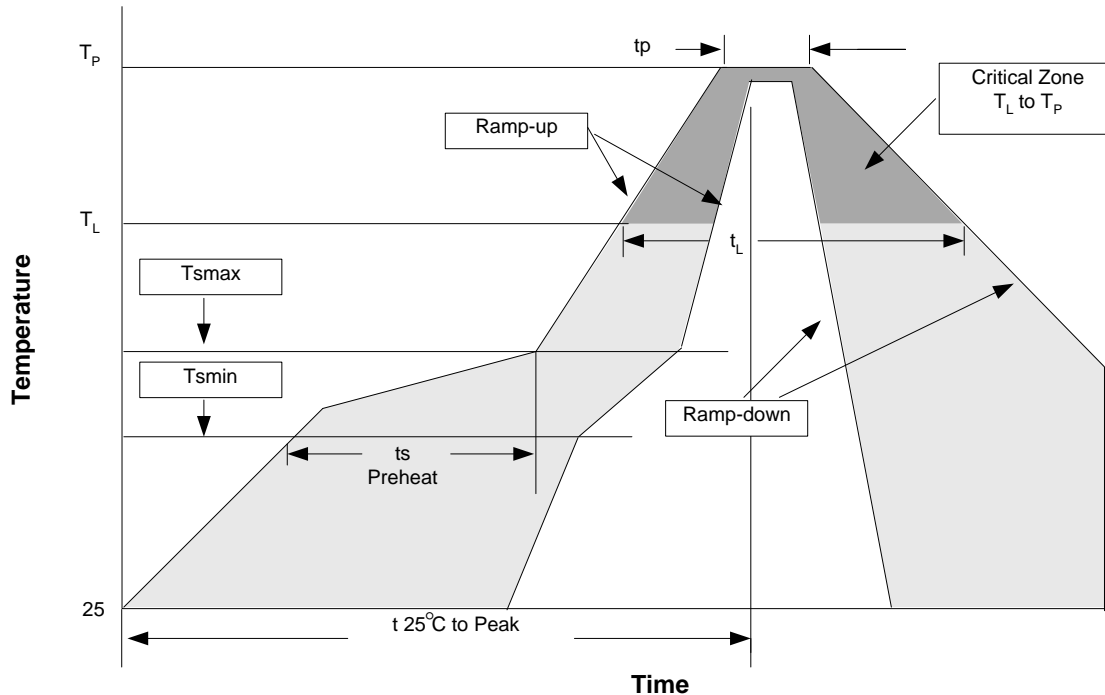

Reliability Test Program

| Test item | Method | Description |
|---------------|---------------------|-------------------------------|
| SOLDERABILITY | MIL-STD-883D-2003 | 245°C, 5 sec |
| HOLT | MIL-STD-883D-1005.7 | 1000 Hrs Bias @125°C |
| PCT | JESD-22-B,A102 | 168 Hrs, 100%RH, 121°C |
| TST | MIL-STD-883D-1011.9 | -65°C~150°C, 200 Cycles |
| ESD | MIL-STD-883D-3015.7 | VHBM > 2KV, VMM > 200V |
| Latch-Up | JESD 78 | 10ms, 1 _{tr} > 100mA |

Classification Reflow Profiles

| Profile Feature | Sn-Pb Eutectic Assembly | Pb-Free Assembly |
|--|-------------------------|------------------|
| Average ramp-up rate (T _L to T _P) | 3°C/second max. | 3°C/second max. |
| Preheat | | |
| - Temperature Min (T _{min}) | 100°C | 150°C |
| - Temperature Max (T _{max}) | 150°C | 200°C |
| - Time (min to max) (t _s) | 60-120 seconds | 60-180 seconds |
| Time maintained above: | | |
| - Temperature (T _L) | 183°C | 217°C |
| - Time (t _L) | 60-150 seconds | 60-150 seconds |
| Peak/Classification Temperature (T _p) | See table 1 | See table 2 |
| Time within 5°C of actual Peak Temperature (t _p) | 10-30 seconds | 20-40 seconds |
| Ramp-down Rate | 6°C/second max. | 6°C/second max. |
| Time 25°C to Peak Temperature | 6 minutes max. | 8 minutes max. |

Note: All temperatures refer to topside of the package. Measured on the body surface.

Classification Reflow Profiles (Cont.)

Table 1. SnPb Eutectic Process – Package Peak Reflow Temperatures

| Package Thickness | Volume mm ³ <350 | Volume mm ³ ≥350 |
|-------------------|--------------------------------|--------------------------------|
| <2.5 mm | 240 +0/-5°C | 225 +0/-5°C |
| ≥2.5 mm | 225 +0/-5°C | 225 +0/-5°C |

Table 2. Pb-free Process – Package Classification Reflow Temperatures

| Package Thickness | Volume mm ³ <350 | Volume mm ³ 350-2000 | Volume mm ³ >2000 |
|-------------------|--------------------------------|------------------------------------|---------------------------------|
| <1.6 mm | 260 +0°C* | 260 +0°C* | 260 +0°C* |
| 1.6 mm – 2.5 mm | 260 +0°C* | 250 +0°C* | 245 +0°C* |
| ≥2.5 mm | 250 +0°C* | 245 +0°C* | 245 +0°C* |

* Tolerance: The device manufacturer/supplier **shall** assure process compatibility up to and including the stated classification temperature (this means Peak reflow temperature +0°C. For example 260°C+0°C) at the rated MSL level.

Customer Service

Anpec Electronics Corp.

Head Office :

No.6, Dusing 1st Road, SBIP,
Hsin-Chu, Taiwan, R.O.C.
Tel : 886-3-5642000
Fax : 886-3-5642050

Taipei Branch :

2F, No. 11, Lane 218, Sec 2 Jhongsing Rd.,
Sindian City, Taipei County 23146, Taiwan
Tel : 886-2-2910-3838
Fax : 886-2-2917-3838