



# UM95088

## Tone Dialer

PRELIMINARY

### Features

- Wide Supply Voltage 1.8 ~ 5.5V
- Ceramic oscillator (480K ceramic resonator)
- Fully debounced scanning keyboard
- Minimum tone duration: 73 mS
- Very low tone distortion, less than 1% in band
- On chip power on reset
- Single tone output mode
- Low standby and operating power
- All pins protected against ESD and latch-up
- Low frequency error: max + 0.3%

### General Description

The UM95088 DTMF generator is specifically designed to implement a dual tone telephone dialing system in applications requiring fixed supply operation and high stability tone output level, making it well suited for electronic telephone applications. The device can serve as an interface directly to a standard XY matrix telephone keyboard and operates directly from the telephone lines. All necessary dual-tone frequencies are derived from either the widely used 480 KHz ceramic resonator which pro-

vides high accuracy and stability. The required sinusoidal waveform for the individual tones is digitally synthesized on the chip. The waveform so generated has low total harmonic distortion. With the built-in minimum tone duration function, an adaptive solution for fast dialling/short DTMF output is achieved. A reliable power on reset circuit guaranteed proper function under variety of power supply condition.

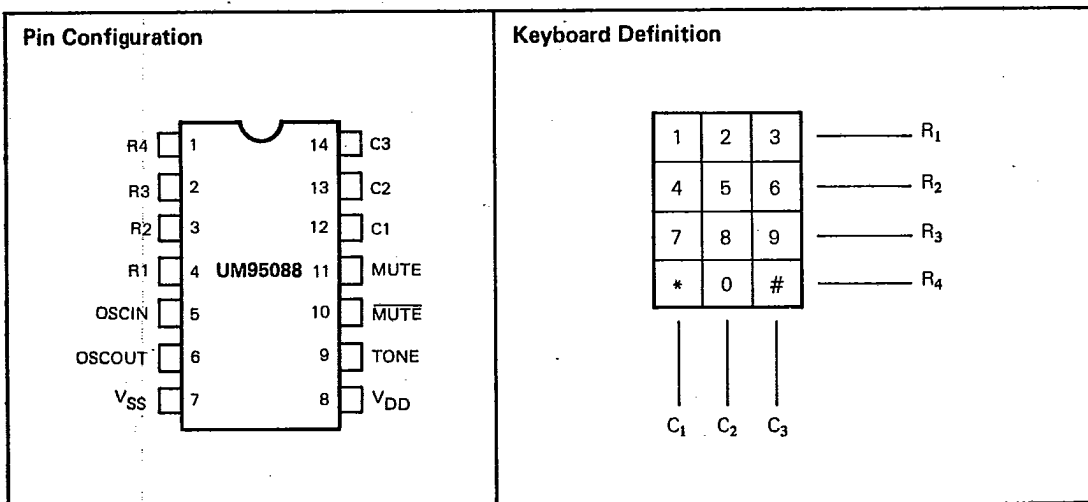

9325812 UNITED MICROELECTRONICS

92D 00418

DT-75-07-07



UM95088

**Absolute Maximum Ratings\***

**\*Comments**

Power Supply Voltage ( $V_{DD} - V_{SS}$ ) . . . . . -0.3V to +6.0V  
 Operating Temperature (Top) . . . . . -20°C to +70°C  
 Storage Temperature (Tstg) . . . . . -55°C to +150°C  
 Applied Voltage on Any Pin ( $V_{IN}$ )  
 . . . . .  $V_{SS} - 0.3 \leq V_{IN} \leq V_{DD} + 0.3$

Stresses above those listed under "Absolute Maximum Ratings" may cause permanent damage to the device. This is a stress rating only and functional operation of the device at these or any other conditions above those indicated in the operational sections of this specification is not implied.

**Electrical Characteristics**

( $V_{DD} - V_{SS} = 3.5V$ ,  $F_{osc} = 480$  KHz,  $T_{op} = 25^\circ C$ , unless otherwise specified.)

Parameter	Symsol	Min.	Typ.	Max.	Units	Conditions	
Operating Voltage	$V_{DD}$	1.8		5.5	V		
Operating Current	$I_{DD}$		0.7		mA	Oscillator running, all outputs unloaded.	
Standby Current	$I_{DD1}$		5		$\mu A$	$V_{DD} = 2.0V$	all outputs unloaded.
	$I_{DD2}$		10		$\mu A$	$V_{DD} = 3.5V$	
<b>OUTPUT SINK CURRENT</b>							
MUTE, MUTE	$I_{OL1}$	0.5			mA	$V_{DD} = 2.0V$	$V_{OL} = 0.5V$
	$I_{OL2}$	1.0			mA	$V_{DD} = 3.5V$	
<b>OUTPUT SOURCE CURRENT</b>							
MUTE	$I_{OH1}$	0.2			mA	$V_{DD} = 2.0V$	$V_{OH} = 1.5V$
	$I_{OH2}$	0.5			mA	$V_{DD} = 3.5V$	$V_{OH} = 3.0V$
Single Column Tone Output Amplitude	$V_{PP1}$		520		mV	$V_{DD} = 2.0V$	Rload = 15 Kohm
	$V_{PP2}$		910		mV	$V_{DD} = 3.5V$	
Valley of Single Row/Column Tone	$V_{vally}$		0.45		$V_{DD}$	Rload = 15 Kohm	
Single Row Tone Output Amplitude	$V_{PP1}$		390		mV	$V_{DD} = 2.0V$	Rload = 15 Kohm
	$V_{PP2}$		680		mV	$V_{DD} = 3.5V$	
Distortion		%DIS		5			

Tone Dialer



**UM95088**

**Table 1. Comparison of Specified vs Actual Tone Frequencies Generated by the UM95088**

Output Frequency (Hz)		% Error*
Specified	Actual	
697 (Row 1)	695.65	-0.19
770 (Row 2)	769.23	-0.10
852 (Row 3)	851.06	-0.11
941 (Row 4)	941.18	+0.02
1,209 (Column 1)	1,212.12	+0.26
1,336 (Column 2)	1,333.33	-0.20
1,477 (Column 3)	1,481.48	+0.30

\*: % Error does not include oscillator drift.

The UM95088 DTMF generator is well designed with an 8-Level, 16-Segment, 1/2 V<sub>DD</sub> reference voltage structure. The THD (Total Harmonic Distortion) of the UM95088 DTMF output is less than 1% in-band. The Temperature Coefficient of the DTMF output amplitude is balanced to zero from the adaptive DTMF generator structure.

The output strength of the Column Tone is pre-emphasized 2.5 dB than the Row Tone.

The typical equivalent output impedance of this DTMF generator is 1.5K ohm.

**Pin. Description**

**Keyboard**

These are the keyboard input pins of the UM95088. The

**Timing Diagram**

(When power supply is ready)

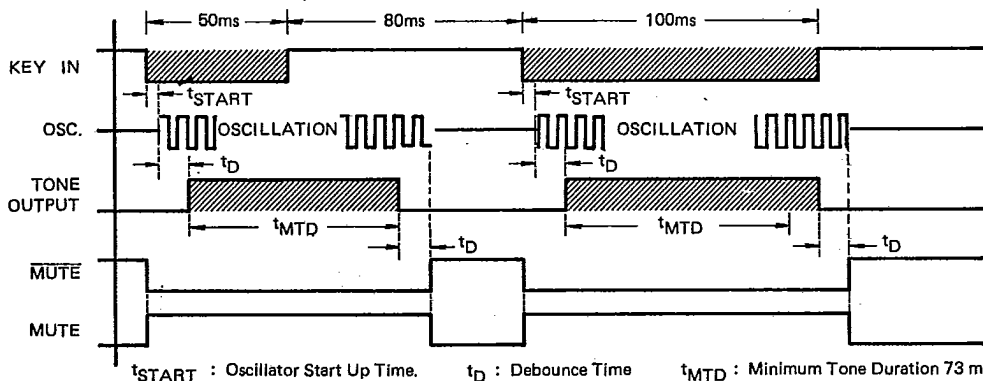

output of the Column pins C<sub>1</sub>, C<sub>2</sub>, C<sub>3</sub> are high and the output of the Row pins R<sub>1</sub>, R<sub>2</sub>, R<sub>3</sub>, R<sub>4</sub> and low in the stand-by state. Each column has a pull-up resistor (120 K ohm typically). A logic low is presented at the connected row and column pins.

Debouncing circuit is provided (10 ms typically). Multiple keys – Single Tone output is provided for testing purpose.

**Oscillator (OSCIN, OSCOUT)**

The oscillator is designed to operate at a full range of supply voltage (1.8 – 5.5V) with very good voltage stability for ceramic resonator. The oscillator is activated upon any-key-down. Start up time is max. 5 ms at V<sub>DD</sub> = 3.5V.

**Tone Output (TONE)**

This is the DTMF output pin. The output impedance is 1.5 K ohm typically. This pin is forced to V<sub>SS</sub> when there is no output. The column tone to row tone ratio is 2.5 dB typically. A single tone is accessed by depressing two or more keys in a row for appropriate row tone; and two or more keys in a column for appropriate column tone.

**MUTE Output**

This is an inverter output. This output is activated during tone output. The source/sink capability is 0.2/0.5 mA at 2V supply voltage and 0.5V drain voltage fall.

**MUTE Output**

This is an open drain output device. This output is activated during tone output. This output can sink the current from higher voltage source (> V<sub>DD</sub>) directly.



**UM95088**

**A Low Cost Touch Tone Telephone Application Example**

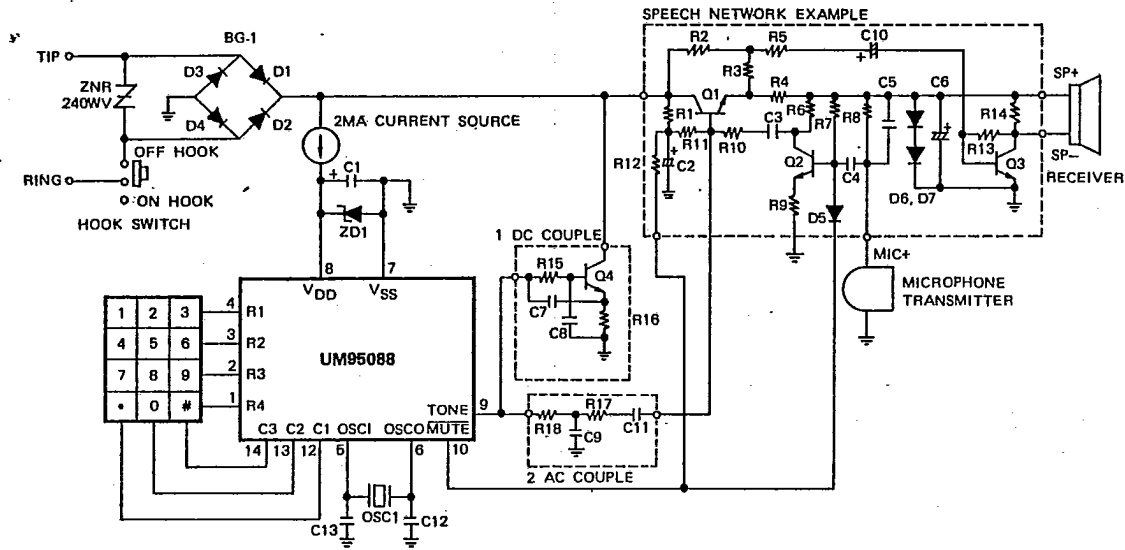

**Parts List**

**Diode**

D<sub>1</sub> ~ D<sub>4</sub>: IN4004x4  
 D<sub>5</sub>, D<sub>6</sub>, D<sub>7</sub>: IN4148x3

**Transistor**

Q<sub>1</sub> ~ Q<sub>4</sub>: 2SC945x4

**Resistor:**

R1 : 4K7  
 R2 : 3K3  
 R3 : 180Ω  
 R4 : 22Ω  
 R5 : 1K2  
 R6 : 1K2  
 R7 : 680K  
 R8 : 2K2  
 R9 : 75Ω  
 R10: 4K7  
 R11: 22K  
 R12: 10K  
 R13: 10K  
 R14: 1K2  
 R15: 1K2  
 R16: 220Ω  
 R17: 10K  
 R18: 1K2

**Capacitor**

C1 : 10μF/16WV  
 C2 : 10μF/16WV  
 C3 : 0.1μF/50WV  
 C4 : 0.033μF/50WV  
 C5 : 0.033μF/50WV  
 C6 : 47μF/10WV  
 C7 : 0.033μF/50WV  
 C8 : 0.033μF/50WV  
 C9 : 0.0033μF/50WV  
 C10: 1μF/10WV  
 C11: 0.033μF/50WV  
 C12: 100PF  
 C13: 100PF.

**Oscillator**

OSCI: 480KHz Ceramic Resonator

**High Voltage Protector**

ZNR: 240WV/1W Varistor

**Zener Diode**

ZDI: 3.9WV/0.5W ZD

**Receiver**

100 OHM receiver

**Transmitter**

ECM mic.

Tone Dial



**UM95088**

**Touch Tone Telephone Application**

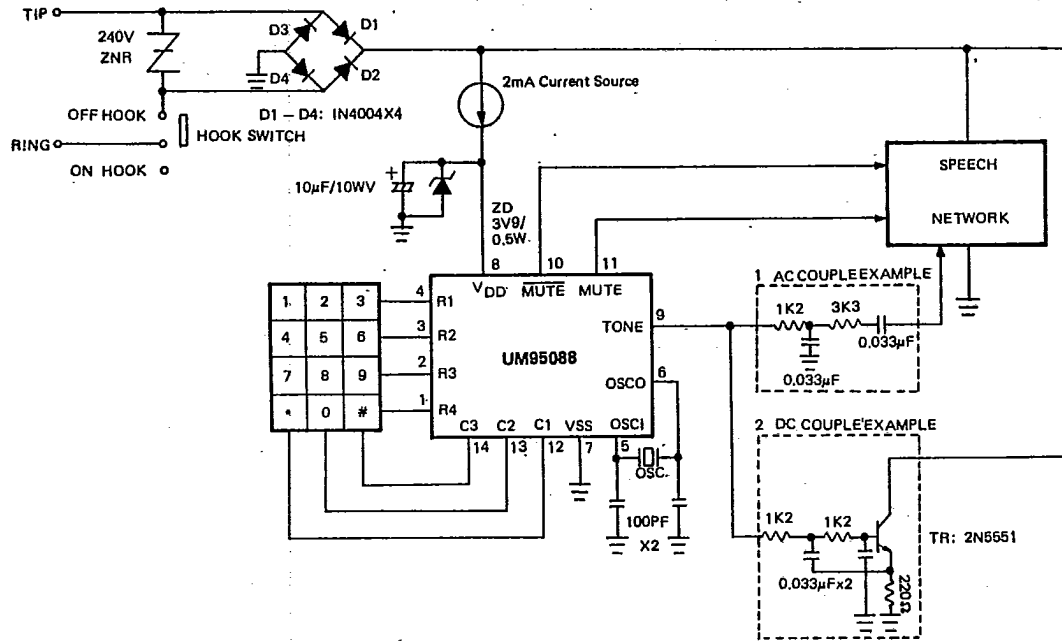

Note: AC couple and DC couple Interface is determined by matching with the speech network.