

GENERAL DESCRIPTION

Fast SCSI and Ultra SCSI require the use of active terminations at both ends of every cable segment in a SCSI system with single-ended drivers and receivers. The DS21S07A SCSI terminator, which is fully compliant with these standards, enables the designer to gain the benefits of active termination: greater immunity to voltage drops on the TERMPWR (TERMination PoWeR) line, enhanced high-level noise immunity, intrinsic TERMPWR decoupling, and very low quiescent current consumption. The DS21S07A integrates a regulator and nine precise switched 110Ω termination resistors into a monolithic IC. The DS21S07A can be electrically isolated from the SCSI bus without physical removal from the SCSI device.

FEATURES

- Fully Compliant with SCSI-1, Fast SCSI, and Ultra SCSI
- Backward Compatible to the DS2107 and DS2107A
- Provides Active Termination for Nine Signal Lines
- Laser-Trimmed 110Ω Termination Resistors Have 2% Tolerance
- Low Drop-Out Voltage Regulator
- Power-Down Mode Isolates Termination Resistors from the Bus
- SCSI Bus Hot Plug Compatible
- Fully Supports Actively Negated SCSI Signals
- On-Board Thermal Shutdown Circuitry
- 16-Pin Plastic SO (DS21S07AS) and 20-Pin Plastic TSSOP (Thin Shrink Small Outline Package) (DS21S07AE)

PIN CONFIGURATIONS

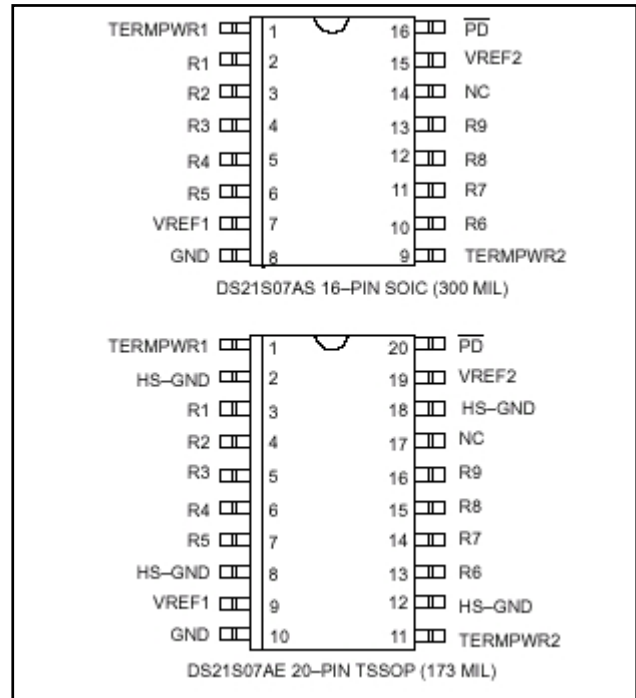

ACTUAL FOOTPRINT SIZE

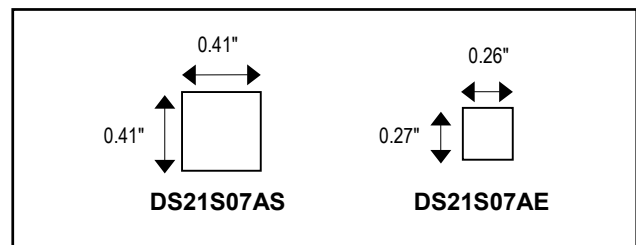

ORDERING INFORMATION

PART	VOLTAGE (V)	PIN-PACKAGE	TOP MARK
DS21S07AS	5	16SO	DS21T07S
DS21S07AS+	5	16SO	DS21T07S
DS21S07AS/T&R	5	16SO	DS21T07S
DS21S07AS+T&R	5	16SO	DS21T07S
DS21S07AE	5	20TSSOP	DS21T07E
DS21S07AE/T&R	5	20TSSOP	DS21T07E

+ Denotes lead-free package. The top mark includes a "+" on lead-free packages.
Note: All devices are specified over the 0°C to +70°C operating temperature range.

FUNCTIONAL DESCRIPTION

The DS21S07A consists of a bandgap reference, buffer amplifier, and nine termination resistors (Figure 1). The bandgap reference circuit produces a precise 2.55V level that is fed to a buffer amplifier. The buffer produces a 2.85V level and can source at least 24mA into each of the termination resistors when the signal line is low (active). When the driver for a given signal line turns off, the terminator pulls the signal line to 2.85V (quiescent state). To handle actively negated SCSI signals, the buffer can sink at least 200mA, and VREF will move less than 60mV. When all lines settle in the quiescent state, the regulator consumes about 2.5mA. When the DS21S07A is put into power-down mode by bringing $\overline{\text{PD}}$ low, the power-down circuitry turns off the transistors on each signal line. This isolates the DS21S07A from the signal lines and effectively removes it from the circuit. The power-down pin ($\overline{\text{PD}}$) has an internal 50k Ω pullup resistor. To place the DS21S07A into an active state, the $\overline{\text{PD}}$ pin should be left open circuited. When installed on disk drives or RAID system components, the DS21S07A will not affect the SCSI bus during a hot plug operation.

To ensure proper operation, both the TERMPWR1 and TERMPWR2 pins must be connected to the SCSI bus TERMPWR line and both the VREF1 and VREF2 pins must be tied together externally. Each DS21S07A requires a 4.7 μF capacitor connected between the VREF pins and ground. Figure 2 details a typical SCSI bus configuration. In an 8-bit-wide SCSI bus arrangement ("A" Cable), two DS21S07A's would be needed at each end of the SCSI cable to terminate the 18 active signal lines. In a 16-bit-wide SCSI bus arrangement ("P" Cable), three DS21S07A's would be needed at each end of the SCSI cable to terminate the 27 active signal lines.

Figure 1. DS21S087A Block Diagram

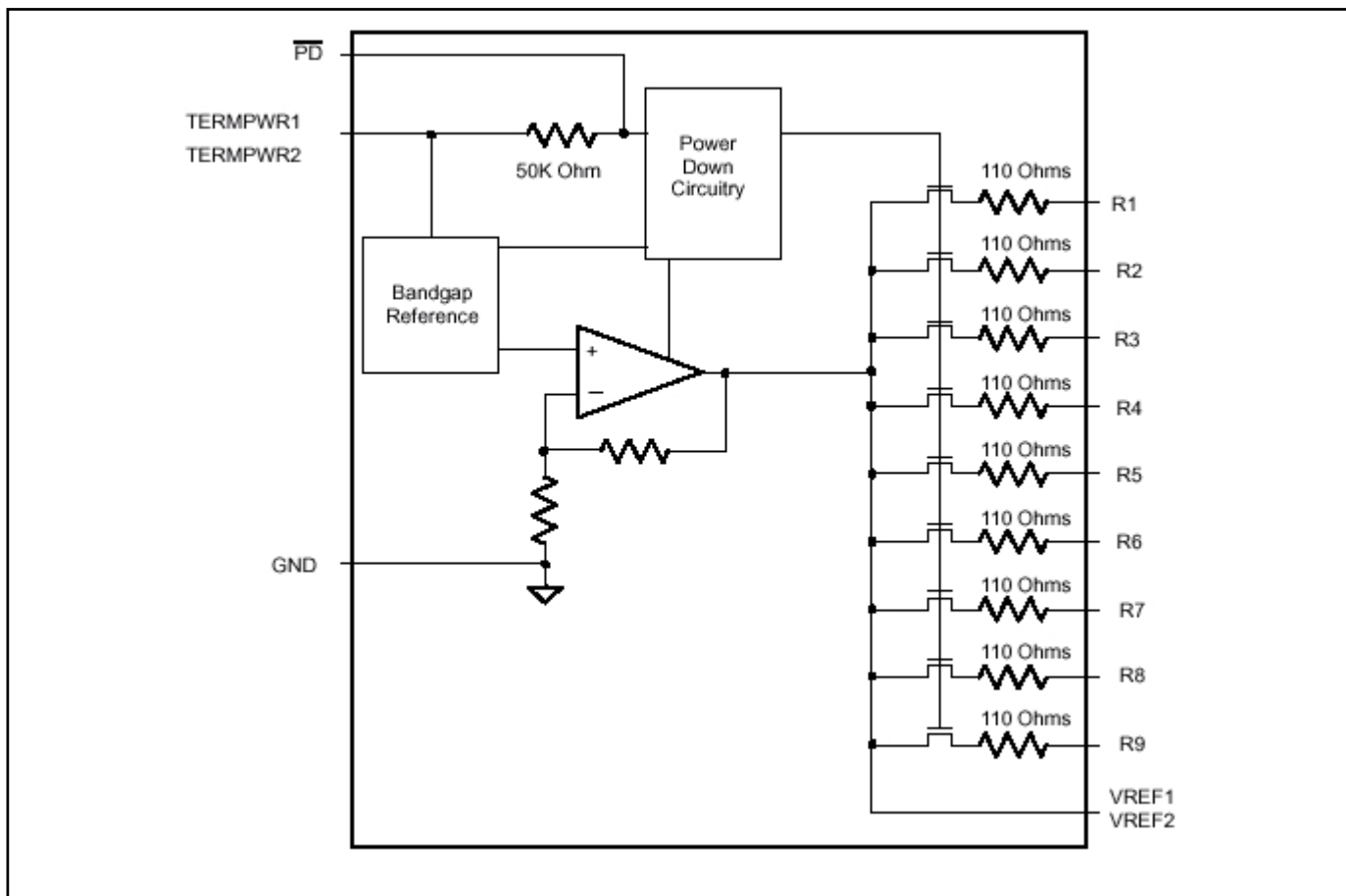
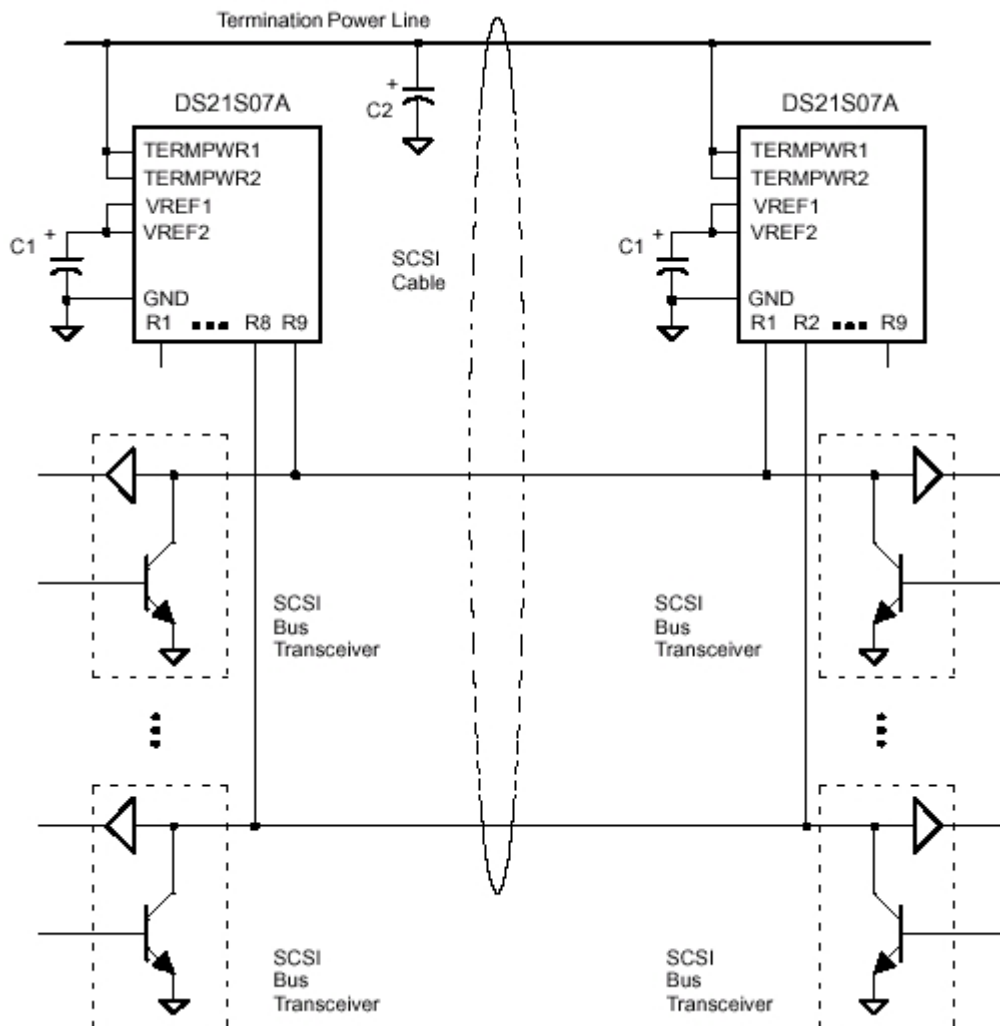

Figure 2. Typical Differential SCSI Bus Configuration

NOTE 1: C1 = 4.7 μ F TANTALUM CAPACITOR; C2 = 2.2 μ F TANTALUM OR 4.7 μ F ALUMINUM CAPACITOR.

NOTE 2: IF THE DS21S07A IS TO BE EMBEDDED INTO A PERIPHERAL THAT WILL ACT AS A TARGET ON A SCSI BUS, IT IS RECOMMENDED THAT TERMPWR BE DERIVED FROM THE SCSI CABLE, NOT GENERATED LOCALLY. IN THIS CONFIGURATION, IF A POWER FAILURE OCCURS IN THE PERIPHERAL, IT WILL NOT AFFECT THE BUS.

NOTE 3: A HIGH-FREQUENCY BYPASS CAPACITOR (0.1 μ F RECOMMENDED) CAN BE ADDED IN PARALLEL TO C1 FOR APPLICATIONS USING FAST RISE/FALL TIME DRIVERS.

Table 1. Pin Description

PIN		NAME	FUNCTION
TSSOP	SO		
1	1	TERMPWR1	Termination Power 1. Should be connected to the SCSI TERMPWR line. Must be decoupled with either a 2.2 μ F capacitor or 4.7 μ F capacitor. See Figure 2.
2, 8, 12, 18	—	HS-GND	Heat Sink Ground. Internally connected to the mounting pad. Should be either grounded or electrically isolated from other circuitry.
3–7, 13–16	2–6, 10–13	R1–R9	Signal Termination 1–9. 110 Ω termination.
9	7	VREF1	Reference Voltage 1. Must be externally connected directly to the VREF2 pin. Must be decoupled with a 4.7 μ F capacitor as shown in Figure 2.
10	8	GND	Ground. 0V, signal ground.
11	9	TERMPWR2	Termination Power 2. Should be connected to the SCSI TERMPWR line. Must be decoupled with either a 2.2 μ F capacitor or 4.7 μ F capacitor. See Figure 2.
17	14	NC	No Connection. Do not connect any signal to this pin.
19	15	VREF2	Reference Voltage 2. Must be externally connected directly to the VREF1 pin. Must be decoupled with a 4.7 μ F capacitor as shown in Figure 2.
20	16	$\overline{\text{PD}}$	Active-Low Power-Down. When tied low, the DS21S07A enters a power-down mode. Contains an internal 50k Ω pullup resistor. Strap low to deactivate the DS21S07A; leave open circuited to activate the DS21S07A

ABSOLUTE MAXIMUM RATINGS

Voltage Range on Any Pin Relative to Ground.....	-1.0V to +7.0V
Operating Temperature Range.....	0°C to +70°C
Storage Temperature Range.....	-55°C to +125°C
Soldering Temperature.....	See IPC/JEDEC J-STD-020 Specification

This is a stress rating only and functional operation of the device at these or any other conditions above those indicated in the operation sections of this specification is not implied. Exposure to absolute maximum rating conditions for extended periods of time may affect device reliability.

RECOMMENDED OPERATING CONDITIONS

($T_A = 0^\circ\text{C}$ to $+70^\circ\text{C}$)

PARAMETER	SYM	MIN	TYP	MAX	UNITS	NOTES
TERMPWR Voltage	V_{TP}	4.00		5.50	V	
PD Active	V_{PDA}	-0.3		+0.8	V	
PD Inactive	V_{PDI}	2.0		$V_{TP} + 0.3$	V	

DC CHARACTERISTICS

($T_A = 0^\circ\text{C}$ to $+70^\circ\text{C}$)

PARAMETER	SYMBOL	MIN	TYP	MAX	UNITS	NOTES
TERMPWR Current	I_{TP}			250	mA	1, 3
				5	mA	1, 4
Power-Down Current	I_{PD}		100	150	μA	1, 2, 5
Termination Resistance	R_{TERM}	108	110	112	Ω	1, 2
Die Thermal Shutdown	T_{SD}	150			$^\circ\text{C}$	1, 6
Power-Down Termination Capacitance	C_{PD}		3.0	5.0	pF	1, 2, 5, 6
Input Leakage High	I_{IH}	-1.0			μA	1, 8
Input Leakage Low	I_{IL}			1.0	μA	1, 7

REGULATOR CHARACTERISTICS

($T_A = 0^\circ\text{C}$ to $+70^\circ\text{C}$)

PARAMETER	SYMBOL	MIN	TYP	MAX	UNITS	NOTES
Output Voltage	V_{REF}	2.79	2.85	2.93	V	1, 2
Drop-Out Voltage	V_{DROP}		0.50	0.75	V	3, 6
Line Regulation	LI_{REG}		1.0	2.0	%	1, 4
Load Regulation	LO_{REG}		1.3	3.0	%	1, 3
Current Limit	I_{LIM}		350		mA	1
Sink Current	I_{SINK}	200			mA	1

NOTES:

- 1) $4.00\text{V} < \text{TERMPWR} < 5.50\text{V}$.
- 2) $0.0\text{V} < \text{signal lines} < \text{TERMPWR}$.
- 3) All signal lines = 0V .
- 4) All signal lines open.
- 5) $\overline{\text{PD}} = 0\text{V}$.
- 6) Guaranteed by design; not production tested.
- 7) R1 to R9 only.
- 8) R1 to R9 and $\overline{\text{PD}}$.

PACKAGE INFORMATION

(The package drawing(s) in this data sheet may not reflect the most current specifications. For the latest package outline information, go to www.maxim-ic.com/DallasPackInfo.)

REVISIONS			
LTR	DESCRIPTION	DATE	APPROVED
A	NEW DRAWING	5/18	J.W.
B	INC. ECN NO. 8680		

LTR	MIN	MAX	16 PIN		18 PIN		20 PIN		24 PIN		28 PIN	
			MIN	MAX	MIN	MAX	MIN	MAX	MIN	MAX	MIN	MAX
A	IN. MM	0.094 2.39	0.105 2.67									
A1	IN. MM	0.004 0.102	0.012 0.30									
A2	IN. MM	0.089 2.26	0.095 2.41									
b	IN. MM	0.013 0.33	0.020 0.51									
C	IN. MM	0.009 0.229	0.013 0.33									
D	IN. MM	→	0.398 10.11	0.412 10.46	0.448 11.38	0.462 11.73	0.498 12.65	0.511 12.99	0.598 15.19	0.612 15.54	0.698 17.73	0.712 18.08
e	IN. MM	.050 BSC 1.27 BSC										
E1	IN. MM	0.290 7.37	0.300 7.62									
H	IN. MM	0.398 10.11	0.416 10.57									
L	IN. MM	0.016 0.40	0.040 1.02									
theta		0°	8°									

THE CHAMFER ON THE BODY IS OPTIONAL.
 IF IT IS NOT PRESENT, A TERMINAL 1 IDENTIFIER
 MUST BE POSITIONED SO THAT 1/2 OR MORE OF
 IT'S AREA IS CONTAINED IN THE HATCHED ZONE.

SIGNATURE	DATE	
DOC. CONTROL: J.WILKINS	5/94	
ENGR. MGR: B.W.MCARTY	5/94	
MFG. ENGR: C.M.SELLS	5/94	
CHECKED BY: C.M.SELLS	5/94	
DRAWN BY: M.W.C.	5/94	
DO NOT SCALE DWG.		TITLE: PACKAGE OUTLINE .300" SOIC 16,18,20,24&28 LD. SIZE: A FSCM NO: PART NO: 56-G4009-001 REV: B SCALE: N/A SHEET 1 OF 1

PACKAGE INFORMATION (continued)

(The package drawing(s) in this data sheet may not reflect the most current specifications. For the latest package outline information, go to www.maxim-ic.com/DallasPackInfo.)

REVISIONS			
LTR	DESCRIPTION	DATE	APPROVED
A	NEW DRAWING	12/92	K.D.
B	INC. ECN NO. 6791		

NOTES:
1. DIMENSION "D" INCLUDES MOLD MISSMATCH, FLASH, AND PROTRUSIONS.

DIM	MIN	MAX
A	—	1.10
A1	0.05	—
A2	0.75	1.05
c	0.09	0.18
phi	0°	8°
L	0.50	0.70
e1	0.65	BSC
B	0.18	0.30
D	6.40	6.90
E	4.40	NOM
G	0.25	REF
H	6.25	6.55

DIMENSIONS ARE IN MILLIMETERS

SIGNATURE		DATE						
DOC. CONTROL:	J.WILKINS	6/92						
ENGR. MGR:	J.HUNDT	6/92						
MFG. ENGR:	B.W.M.	6/92						
CHECKED BY:	B.W.M.	6/92						
DRAWN BY:	M.W.C.	6/92	TITLE					
DO NOT SCALE DWG.			MARKETING OUTLINE, 20 LD. TSSOP, 4.4 MM BODY					
			<table border="1" style="width: 100%; border-collapse: collapse;"> <tr> <td>SIZE</td> <td>FSCM NO</td> <td>PART NO.</td> <td>REV</td> </tr> <tr> <td>A</td> <td></td> <td>56-G2010-000</td> <td>B</td> </tr> </table>	SIZE	FSCM NO	PART NO.	REV	A
SIZE	FSCM NO	PART NO.	REV					
A		56-G2010-000	B					
SCALE N/A		SHEET 1 OF 1						

Maxim/Dallas Semiconductor cannot assume responsibility for use of any circuitry other than circuitry entirely embodied in a Maxim/Dallas Semiconductor product. No circuit patent licenses are implied. Maxim/Dallas Semiconductor reserves the right to change the circuitry and specifications without notice at any time.

Maxim Integrated Products, 120 San Gabriel Drive, Sunnyvale, CA 94086 408-737-7600

© 2006 Maxim Integrated Products • Printed USA

The Maxim logo is a registered trademark of Maxim Integrated Products, Inc. The Dallas logo is a registered trademark of Dallas Semiconductor Corporation.