

4-BIT SINGLE-CHIP MICROCONTROLLER
FOR INFRARED REMOTE CONTROL TRANSMISSION

DESCRIPTION

Equipped with low-voltage 1.8V operation, a carrier generation circuit for infrared remote control transmission, a standby release function through key entry, and a programmable timer, the μ PD6133 and 6134 are suitable for infrared remote control transmitters.

For the μ PD6133 and 6134, we have made available the one-time PROM product μ PD61P34B for program evaluation or small-quantity production.

FEATURES

- Program memory (ROM)
 - μ PD6133: 512×10 bits
 - μ PD6134: 1002×10 bits
- Data memory (RAM): 32×4 bits
- Built-in carrier generation circuit for infrared remote control
- 9-bit programmable timer : 1 channel
- Command execution time : $8 \mu\text{s}$ (when operating at $f_x = 1$ MHz: ceramic oscillation)
- Stack level : 1 level (Stack RAM is for data memory RF as well.)
- I/O pins ($K_{I/O}$) : 8 units
- Input pins (K_I) : 4 units
- Sense input pin (S_0) : 1 unit
- $S_1/\overline{\text{LED}}$ pin (I/O) : 1 unit (When in output mode, this is the remote control transmission display pin.)
- Power supply voltage : $V_{DD} = 1.8$ to 3.6 V (when operating at $f_x = 500$ kHz)
 $V_{DD} = 2.2$ to 3.6 V (when operating at $f_x = 1$ MHz)
- Operating ambient temperature : $T_A = -40$ to $+85$ °C
- Oscillation frequency : $f_x = 300$ kHz to 1 MHz
- POC circuit (Mask option)

APPLICATION

Infrared remote control transmitter (for AV and household electric appliances)

Unless otherwise stated, the μ PD6133 is taken as a representative product in this document.

The information in this document is subject to change without notice. Before using this document, please confirm that this is the latest version.
 Not all devices/types available in every country. Please check with local NEC representative for availability and additional information.

ORDERING INFORMATION

Part Number	Package
μPD6133GS-xxx	20-pin plastic SOP (300 mil)
μPD6134GS-xxx	20-pin plastic SOP (300 mil)
★ μPD6134MC-xxx-5A4	20-pin plastic SSOP (300 mil)

Remark xxx indicates ROM code suffix.

PIN CONFIGURATION (TOP VIEW)

20-pin Plastic SOP (300 mil)

- μPD6133GS-xxx
- μPD6134GS-xxx

★ **20-pin Plastic SSOP (300 mil)**

- μPD6134MC-xxx-5A4

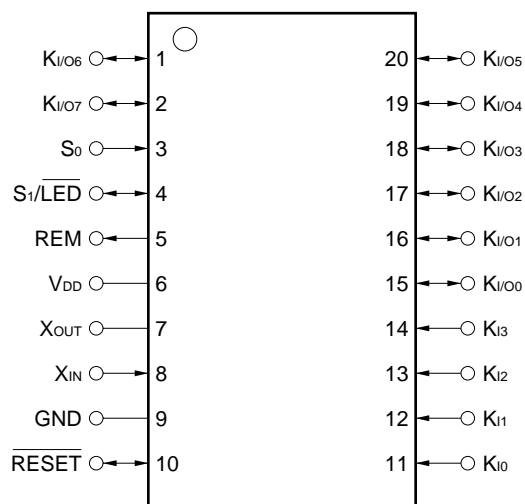

Caution The pin numbers of KI and KI/O are in the reverse order of the μPD6600A and 6124A.

BLOCK DIAGRAM

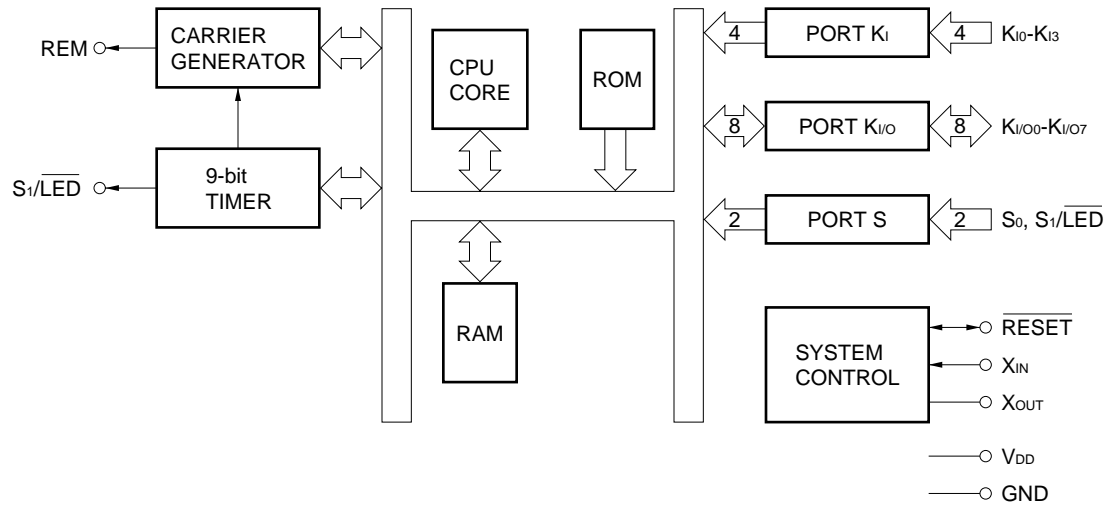

LIST OF FUNCTIONS

Item	μPD6133	μPD6134	μPD61P34B
ROM capacity	512 × 10 bit	1002 × 10 bit	1002 × 10 bits
	Mask ROM		One-time PROM
RAM capacity	32 × 4 bits		
Stack	1 level (multiplexed with RF of RAM)		
I/O pins	<ul style="list-style-type: none"> • Key input (Ki) : 4 • Key I/O (Ki/O) : 8 • Key extended input (S0, S1) : 2 • Remote control transmission display output (LED) : 1 (multiplexed with S1 pin) 		
Number of keys	<ul style="list-style-type: none"> • 32 keys • 48 keys (when extended by key extension input) • 96 keys (when extended by key extension input and diode) 		
Clock frequency	Ceramic oscillation <ul style="list-style-type: none"> • $f_x = 300 \text{ kHz to } 1 \text{ MHz}$ • $f_x = 300 \text{ to } 500 \text{ kHz (with POC circuit)}$ 		
Instruction execution time	8 μs ($f_x = 1 \text{ MHz}$)		
Carrier frequency	$f_x, f_x/2, f_x/8, f_x/12, f_x/16, f_x/24, \text{ no carrier (high level)}$		
Timer	9-bit programmable timer: 1 channel		
POC circuit	Mask option		Internal
★ Supply voltage	$V_{DD} = 1.8 \text{ to } 3.6 \text{ V}$		$V_{DD} = 2.2 \text{ to } 3.6 \text{ V}$
Operating ambient temperature	<ul style="list-style-type: none"> • $T_A = -40 \text{ to } +85 \text{ }^\circ\text{C}$ • $T_A = -20 \text{ to } +70 \text{ }^\circ\text{C (with POC circuit)}$ 		
★ Package	<ul style="list-style-type: none"> • 20-pin plastic SOP (300 mil) 	<ul style="list-style-type: none"> • 20-pin plastic SOP (300 mil) • 20-pin plastic SSOP (300 mil) 	

TABLE OF CONTENTS

1. PIN FUNCTIONS	6
1.1 List of Pin Functions	6
1.2 INPUT/OUTPUT Circuits of Pins	7
1.3 Dealing with Unused Pins	8
2. INTERNAL CPU FUNCTIONS	9
2.1 Program Counter (PC)	9
2.2 Stack Pointer (SP)	9
2.3 Address Stack Register (ASR (RF))	9
2.4 Program Memory (ROM)	10
2.5 Data Memory (RAM)	10
2.6 Data Pointer (DP)	11
2.7 Accumulator (A)	11
2.8 Arithmetic and Logic Unit (ALU)	12
2.9 Flags	12
2.9.1 Status flag (F)	12
2.9.2 Carry flag (CY)	13
3. PORT REGISTERS (PX)	14
3.1 K _{I/O} Port (P0)	15
3.2 K _I Port/Special Ports (P1)	16
3.2.1 K _I port (P11: bits 4-7 of P1)	16
3.2.2 S ₀ port (bit 2 of P1)	16
3.2.3 S ₁ /LED (bit 3 of P1)	16
3.3 Control Register 0 (P3)	17
3.4 Control Register 1 (P4)	18
4. TIMER	19
4.1 Timer Configuration	19
4.2 Timer Operation	20
4.3 Carrier Output	21
4.4 Software Control of Timer Output	21
5. STANDBY FUNCTION	22
5.1 Outline of Standby Function	22
5.2 Standby Mode Setup and Release	23
5.3 Standby Mode Release Timing	24
6. RESET PIN	26
7. POC CIRCUIT (MASK OPTION)	27
7.1 Functions of POC Circuit	28
7.2 Oscillation Check at Low Supply Voltage	28
8. SYSTEM CLOCK OSCILLATOR	29

9. INSTRUCTION SET	30
9.1 Machine Language Output by Assembler	30
9.2 Circuit Symbol Description	31
9.3 Mnemonic to/from Machine Language (Assembler Output) Contrast Table	32
9.4 Accumulator Operation Instructions	36
9.5 Input/Output Instructions	39
9.6 Data Transfer Instructions	40
9.7 Branch Instructions	42
9.8 Subroutine Instructions	43
9.9 Timer Operation Instructions	44
9.10 Others	45
10. ASSEMBLER RESERVED WORDS	47
10.1 Mask Option Directives	47
10.1.1 OPTION and ENDOP directives	47
10.1.2 Mask option definition directives	47
11. ELECTRICAL SPECIFICATIONS	48
12. CHARACTERISTIC CURVE (REFERENCE VALUES)	52
13. APPLIED CIRCUIT EXAMPLE	54
14. PACKAGE DRAWINGS	55
15. RECOMMENDED SOLDERING CONDITIONS	57
APPENDIX A. DEVELOPMENT TOOLS	58
APPENDIX B. FUNCTIONAL COMPARISON BETWEEN μPD6133 SUBSERIES AND OTHER SUBSERIES	59
APPENDIX C. EXAMPLE OF REMOTE-CONTROL TRANSMISSION FORMAT (in the case of NEC transmission format in command one-shot transmission mode)	60

1. PIN FUNCTIONS

1.1 List of Pin Functions

Pin No.	Symbol	Function	Output Format	When Reset
1 2 15-20	K _{I/O0} -K _{I/O7}	These pins refer to the 8-bit I/O ports. I/O switching can be made in 8-bit units. In INPUT mode, a pull-down resistor is added. In OUTPUT mode, they can be used as the key scan output of the key matrix.	CMOS push-pull ^{Note 1}	High-level output
3	S ₀	Refers to the input port. Can also be used as the key return input of the key matrix. In INPUT mode, the availability of the pull-down resistor of the S ₀ and S ₁ ports can be specified by software in terms in 2-bit units. If INPUT mode is canceled by software, this pin is placed in OFF mode and enters the high-impedance state.	—	High-impedance (OFF mode)
4	S ₁ /LED	Refers to the I/O port. In INPUT mode (S ₁), this pin can also be used as the key return input of the key matrix. The availability of the pull-down resistor of the S ₀ and S ₁ ports can be specified by software in 2-bit units. In OUTPUT mode (LED), it becomes the remote control transmission display output (active low). When the remote control carrier is output from the REM output, this pin outputs the low level from the LED output synchronously with the REM signal.	CMOS push-pull	High-level output (LED)
5	REM	Refers to the infrared remote control transmission output. The output is active high. Carrier frequency: f _x , f _x /8, f _x /12, high-level, f _x /2, f _x /16, f _x /24 (usable on software)	CMOS push-pull	Low-level output
6	V _{DD}	Refers to the power supply.	—	—
7 8	X _{OUT} X _{IN}	These pins are connected to system clock ceramic resonators.	—	Low level (oscillation stopped)
9	GND	Refers to the ground.	—	—
10	RESET	Normally, this pin is a system reset input. By inputting a low level, the CPU can be reset. When resetting with the POC circuit (mask option) a low level is output. A pull-up resistor is incorporated.	—	—
11-14	K _{I0} -K _{I3} ^{Note 2}	These pins refer to the 4-bit input ports. They can be used as the key return input of the key matrix. The use of the pull-down resistor can be specified by software in 4-bit units.	—	Input (low-level)

- Notes**
1. Be careful about this because the drive capability of the low-level output side is held low.
 2. In order to prevent malfunction, be sure to input a low level to more than one of pins K_{I0} to K_{I3} when reset is released (when RESET pin changes from low level to high level, or POC is released due to supply voltage startup).

1.2 INPUT/OUTPUT Circuits of Pins

The input/output circuits of the μPD6133 pins are shown in partially simplified forms below.

(1) K_{1/00}-K_{1/07}

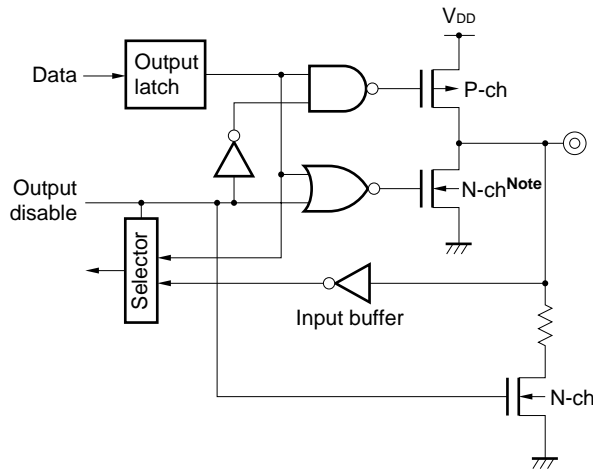

Note The drive capability is held low.

(2) K₁₀-K₁₃

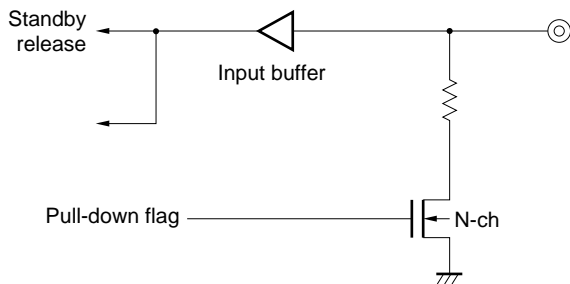

(3) REM

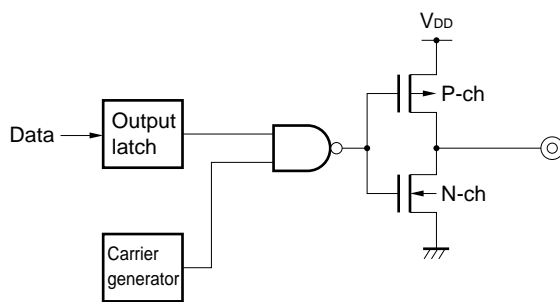

(4) S₀

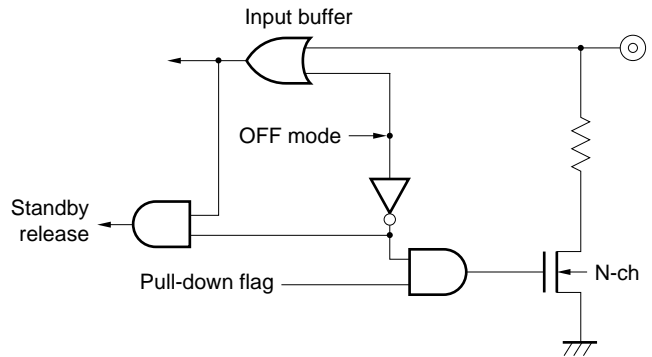

(5) S₁/LED

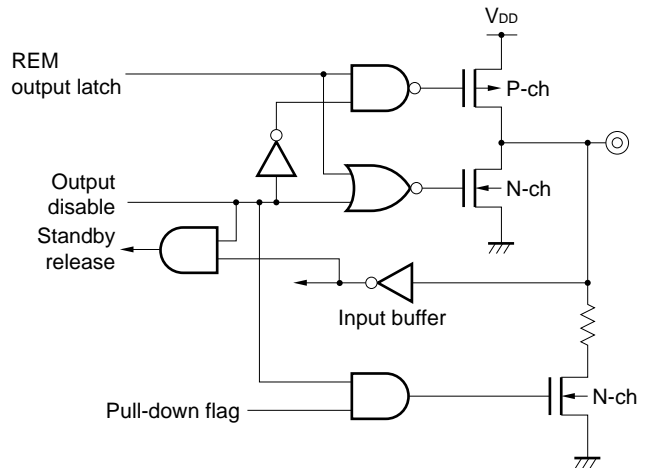

(6) RESET

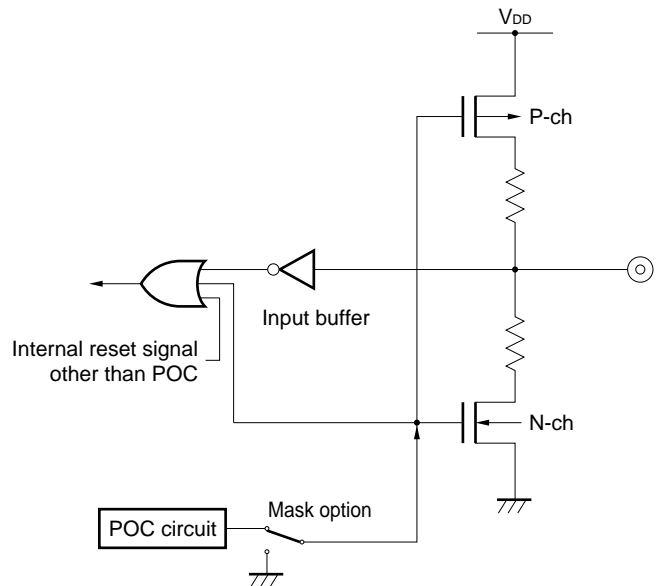

1.3 Dealing with Unused Pins

The following connections are recommended for unused pins.

Table 1-1. Connections for Unused Pins

Pin		Connection	
		Inside the microcontroller	Outside the microcontroller
K _{I/O}	INPUT mode	—	Open
	OUTPUT mode	High-level output	
REM		—	
S ₁ /LED		OUTPUT mode (LED) setting	Directly connected to GND
S ₀		OFF mode setting	
K _I		—	
RESET ^{Note}		Built-in POC circuit	Open

Note If the circuit is an applied one requiring high reliability, be sure to design it in such a manner that the $\overline{\text{RESET}}$ signal is entered externally.

Caution The I/O mode and the terminal output level are recommended to be fixed by setting them repeatedly in each loop of the program.

2. INTERNAL CPU FUNCTIONS

2.1 Program Counter (PC): 10 Bits

Refers to the binary counter that holds the address information of the program memory.

Figure 2-1. Program Counter Organization

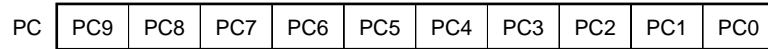

The program counter contains the address of the instruction that should be executed next. Normally, the counter contents are automatically incremented in accordance with the instruction length (byte count) each time an instruction is executed.

However, when executing JUMP instructions (JMP, JC, JNC, JF, JNF), the program counter contains the jump destination address written in the operand.

When executing the subroutine call instruction (CALL), the call destination address written in the operand is entered in the PC after the PC contents at the time are saved in the address stack register (ASR). If the return instruction (RET) is executed after the CALL instruction is executed, the address saved in the ASR is restored to the PC.

When reset, the value of the program counter becomes "000H".

2.2 Stack Pointer (SP): 1 Bit

Refers to the 1-bit register which holds the status of the address stack register.

The stack pointer contents are incremented when the call instruction (CALL) is executed; they are decremented when the return instruction (RET) is executed.

When reset, the stack pointer contents are cleared to "0".

When the stack pointer overflows (stack level 2 or more) or underflows, the CPU is hung up thus a system reset signal is generated and the PC becoming "000H".

As no instruction is available to set a value directly for the stack pointer, it is not possible to operate the pointer by means of a program.

2.3 Address Stack Register (ASR (RF)): 10 Bits

The address stack register saves the return address of the program after a subroutine call instruction is executed.

The low-order 8 bits are arranged in the RF of the data memory as a dual-function RAM. The register holds the ASR value even after the RET is executed.

When reset, it holds the previous data (undefined when turning on the power).

Caution If the RF is accessed as the data memory, the high-order 2 bits of the ASR become undefined.

Figure 2-2. Address Stack Register Organization



**2.4 Program Memory (ROM): 512 steps × 10 bits (μPD6133)
1002 steps × 10 bits (μPD6134)**

The ROM consists of 10 bits per step, and is addressed by the program counter.

The program memory stores programs and table data, etc.

The 22 steps from 3EAH to 3FFH cannot be used in the test program area.

Figure 2-3. Program Memory Map

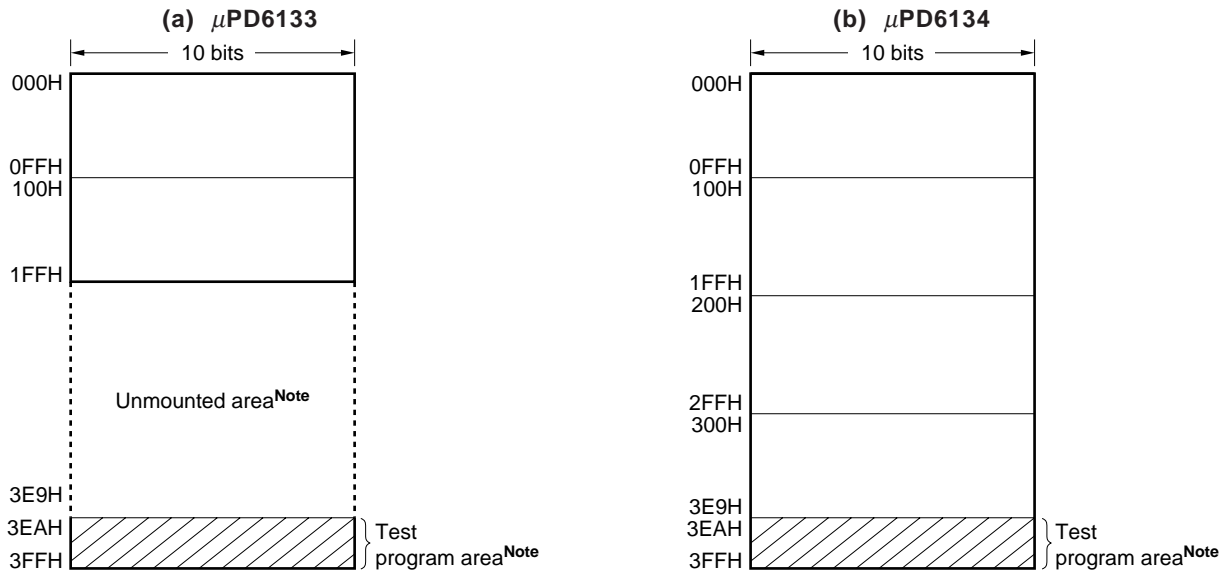

Note The unmounted area and the test program area are so designed that a program or data placed in either of them by mistake is returned to the 000H address.

2.5 Data Memory (RAM): 32 × 4 Bits

The data memory, which is a static RAM consisting of 32 × 4 bits, is used to retain processed data. The data memory is sometimes processed in 8-bit units. R0 can be used as the ROM data pointer.

RF is also used as the ASR.

When reset, R0 is cleared to "00H" and R1 to RF retain the previous data (undefined when turning on the power).

Figure 2-4. Data Memory Organization

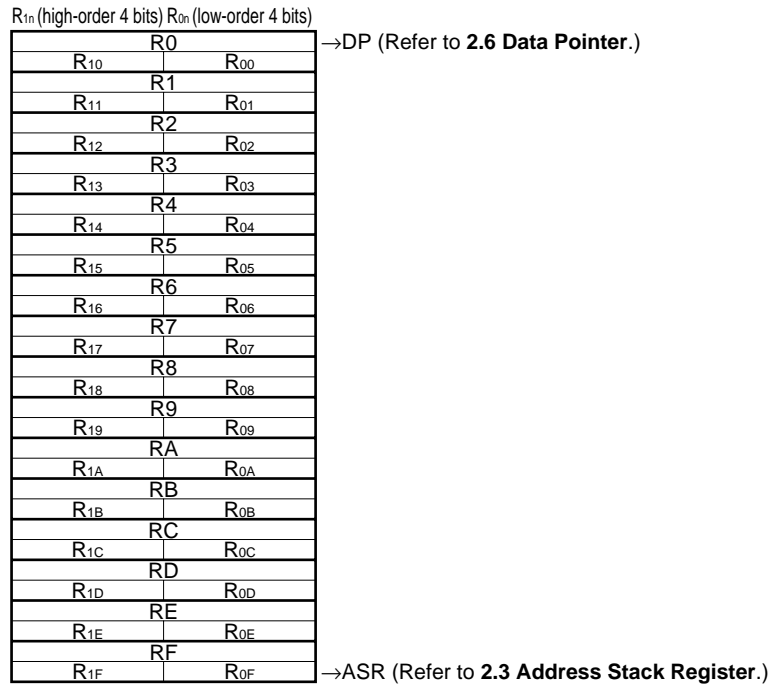

2.6 Data Pointer (DP): 10 Bits

The ROM data table can be referenced by setting the ROM address in the data pointer to call the ROM contents. The low-order 8 bits of the ROM address are specified by R0 of the data memory; and the high-order 2 bits by bits 4 and 5 of the P3 register (CR0).
 When reset, the pointer contents become "000H".

Figure 2-5. Data Pointer Organization



2.7 Accumulator (A): 4 Bits

The accumulator, which refers to a register consisting of 4 bits, plays a leading role in performing various operations.
 When reset, the accumulator contents are left undefined.

Figure 2-6. Accumulator Organization

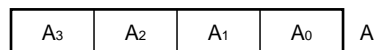

2.8 Arithmetic and Logic Unit (ALU): 4 Bits

The arithmetic and logic unit (ALU), which refers to an arithmetic circuit consisting of 4 bits, executes simple manipulations with priority given to logical operations.

2.9 Flags

2.9.1 Status flag (F)

Pin and timer statuses can be checked by executing the STTS instruction to check the status flag.

The status flag is set (to 1) in the following cases.

- If the condition specified with the operand is met when the STTS instruction has been executed
- When STANDBY mode is canceled.
- When the cancelation condition is met at the point of executing the HALT instruction. (In this case, the system is not placed in STANDBY mode.)

Conversely, the status flag is cleared (to 0) in the following cases:

- If the condition specified with the operand is not met when the STTS instruction has been executed.
- When the status flag has been set (to 1), the HALT instruction executed, but the cancelation condition is not met at the point of executing the HALT instruction. (In this case, the system is not placed in STANDBY mode.)

Table 2-1. Conditions for Status Flag (F) to be Set by STTS Instruction

Operand Value of STTS Instruction				Condition for Status Flag (F) to be Set
b ₃	b ₂	b ₁	b ₀	
0	0	0	0	High level is input to at least one of K ₁ pins.
	0	1	1	High level is input to at least one of K ₁ pins.
	1	1	0	High level is input to at least one of K ₁ pins.
	1	0	1	The down counter of the timer is 0.
1	Either of the combinations of b ₂ , b ₁ , and b ₀ above.			[The following condition is added in addition to the above.] High level is input to at least one of S ₀ and S ₁ pins.

2.9.2 Carry flag (CY)

The carry flag is set (to 1) in the following cases:

- If the ANL instruction or the XRL instruction is executed when bit 3 of the accumulator is "1" and bit 3 of the operand is "1".
- If the RL instruction or the RLZ instruction is executed when bit 3 of the accumulator is "1".
- If the INC instruction or the SCAF instruction is executed when the value of the accumulator is 0FH.

The carry flag is cleared (to 0) in the following cases:

- If the ANL instruction or the XRL instruction is executed when at least either bit 3 of the accumulator or bit 3 of the operand is "0".
- If the RL instruction or the RLZ instruction is executed when bit 3 of the accumulator is "0".
- If the INC instruction or the SCAF instruction is executed when the value of the accumulator is other than 0FH.
- If the ORL instruction is executed.
- When Data is written to the accumulator by the MOV instruction or the IN instruction.

3. PORT REGISTERS (PX)

The K_{I/O} port, the K_I port, the special ports (S₀, S₁/LED), and the control register are treated as port registers. At reset, port register values are shown below.

Figure 3-1. Port Register Organization

Port Register								At Reset
P0								FFH
P ₁₀				P ₀₀				
K _{I/O7}	K _{I/O6}	K _{I/O5}	K _{I/O4}	K _{I/O3}	K _{I/O2}	K _{I/O1}	K _{I/O0}	
P1								× FH ^{Note}
P ₁₁				P ₀₁				
K _{I3}	K _{I2}	K _{I1}	K _{I0}	S ₁ /LED	S ₀	1	1	
P3 (Control register 0)								03H
P ₁₃				P ₀₃				
0	0	DP ₉	DP ₈	TCTL	CARY	MOD ₁	MOD ₀	
P4 (Control register 1)								26H
P ₁₄				P ₀₄				
0	0	K _I pull-down	S ₀ /S ₁ pull-down	0	S ₁ /LEDmode	K _{I/O} mode	S ₀ mode	

Note ×: Refers to the value based on the K_I pin state.

Table 3-1. Relationship between Ports and their Read/Write

Port Name	INPUT Mode		OUTPUT Mode	
	Read	Write	Read	Write
K _{I/O}	Pin state	Output latch	Output latch	Output latch
K _I	Pin state	—	—	—
S ₀	Pin state	—	Note	—
S ₁ /LED	Pin state	—	Pin state	—

Note When in OFF mode, “1” is normally read.

3.1 K_{I/O} Port (P0)

The K_{I/O} port is an 8-bit input/output port for key scan output.

INPUT/OUTPUT mode is set by bit 1 of the P4 register.

If a read instruction is executed, the pin state can be read in INPUT mode, whereas the output latch contents can be read in OUTPUT mode.

If the write instruction is executed, data can be written to the output latch regardless of INPUT or OUTPUT mode.

When reset, the port is placed in OUTPUT mode; and the value of the output latch (P0) becomes 1111 1111B.

The K_{I/O} port contains the pull-down resistor, allowing pull-down in INPUT mode only.

Caution During double pressing of a key, a high-level output and a low-level output may coincide with each other at the K_{I/O} port. To avoid this, the low-level output current of the K_{I/O} port is held low. Therefore, be careful when using the K_{I/O} port for purposes other than key scan output. The K_{I/O} port is so designed that, even when connected directly to V_{DD} within the normal supply voltage range (V_{DD} = 1.8 to 3.6 V), no problem may occur.

Table 3-2. K_{I/O} Port (P0)

Bit	b ₇	b ₆	b ₅	b ₄	b ₃	b ₂	b ₁	b ₀
Name	K _{I/O7}	K _{I/O6}	K _{I/O5}	K _{I/O4}	K _{I/O3}	K _{I/O2}	K _{I/O1}	K _{I/O0}

b₀-b₇ : In reading : In INPUT mode, the K_{I/O} pin's state is read.

In OUTPUT mode, the K_{I/O} pin's output latch contents are read.

In writing : Data is written to the K_{I/O} pin's output latch regardless of INPUT or OUTPUT mode.

3.2 K_I Port/Special Ports (P1)

3.2.1 K_I port (P₁₁: bits 4-7 of P1)

The K_I port is to the 4-bit input port for key entry.

The pin state can be read.

Software can be used to set the availability of the pull-down resistor of the K_I port in 4-bit units by means of bit 5 of the P4 register.

When reset, the pull-down resistor is connected.

Table 3-3. K_I/Special Port Register (P1)

Bit	b ₇	b ₆	b ₅	b ₄	b ₃	b ₂	b ₁	b ₀
Name	K _{I3}	K _{I2}	K _{I1}	K _{I0}	S ₁ /LED	S ₀	(Fixed to "1")	

b₂ : In INPUT mode, state of the S₀ pin is read (Read only).

In OFF mode, this bit is fixed to "1".

b₃ : The state of the S₁/LED pin is read regardless of INPUT/OUTPUT mode (Read only).

b₄-b₇ : The state of the K_I pin is read (Read only).

Caution In order to prevent malfunction, be sure to input a low level to more than one of pins K_{I0} to K_{I3} when reset is released (when RESET pin changes from low level to high level, or POC is released due to supply voltage startup).

3.2.2 S₀ port (bit 2 of P1)

The S₀ port is the INPUT/OFF mode port.

The pin state can be read by setting this port to INPUT mode with bit 0 of the P4 register.

In INPUT mode, software can be used to set the availability of the pull-down resistor of the S₀ and S₁/LED port in 2-bit units by means of bit 4 of the P4 register.

If INPUT mode is canceled (thus set to OFF mode), the pin becomes high-impedance but it also makes that the through current does not flow internally. In OFF mode, "1" can be read regardless of the pin state.

When reset, it is set to OFF mode, thus becoming high-impedance.

3.2.3 S₁/LED (bit 3 of P1)

The S₁/LED port is the input/output port.

It uses bit 2 of the P4 register to set INPUT or OUTPUT mode. The pin state can be read in both INPUT mode and OUTPUT mode.

When in INPUT mode, software can be used to set the availability of the pull-down resistor of the S₀ and S₁/LED ports in 2-bit units by means of bit 4 of the P4 register.

When in OUTPUT mode, the pull-down resistor is automatically disconnected thus becoming the remote transmission display pin (refer to 4. TIMER).

When reset, it is placed in OUTPUT mode, and high level is output.

3.3 Control Register 0 (P3)

Control register 0 consists of 8 bits. The contents that can be controlled are as shown below. When reset, the register becomes 0000 0011B.

Table 3-4. Control Register 0 (P3)

Bit		b ₇	b ₆	b ₅	b ₄	b ₃	b ₂	b ₁	b ₀
Name		—	—	DP (Data pointer)		TCTL	CARY	MOD ₁	MOD ₀
				DP ₉	DP ₈				
Set value	0	Fixed to "0"	Fixed to "0"	0	0	1/1	ON	Refer to Table 3-5.	
	1			1	1	1/2	OFF		
When reset		0	0	0	0	0	0	1	1

- b₀, b₁ : These bits specify the carrier frequency and duty ratio of the REM output.
- b₂ : This bit specifies the availability of the carrier of the frequency specified by b₀ and b₁.
"0" = ON (with carrier); "1" = OFF (without carrier; high level)
- b₃ : This bit changes the carrier frequency and the timer clock's frequency division ratio.
"0" = 1/1 (carrier frequency: the specified value of b₀ and b₁; timer clock: f_x/8)
"1" = 1/2 (carrier frequency: half of the specified value of b₀ and b₁; timer clock: f_x/16)

Table 3-5. Timer Clock and Carrier Frequency Setup

b ₃	b ₂	b ₁	b ₀	Timer Clock	Carrier Frequency (Duty Ratio)
0	0	0	0	f _x /8	f _x (Duty 1/2)
		0	1		f _x /8 (Duty 1/2)
		1	0		f _x /12 (Duty 1/2)
		1	1		f _x /12 (Duty 1/3)
	1	×	×	Without carrier (high level)	
1	0	0	0	f _x /16	f _x /2 (Duty 1/2)
		0	1		f _x /16 (Duty 1/2)
		1	0		f _x /24 (Duty 1/2)
		1	1		f _x /24 (Duty 1/3)
	1	×	×	Without carrier (high level)	

b₄ and b₅ : These bits specify the high-order 2 bits (DP₈ and DP₉) of ROM's data pointer.

Remark ×: don't care

3.4 Control Register 1 (P4)

Control register 1 consists of 8 bits. The contents that can be controlled are as shown below. When reset, the register becomes 0010 0110B.

Table 3-6. Control Register 1 (P4)

Bit		b ₇	b ₆	b ₅	b ₄	b ₃	b ₂	b ₁	b ₀
Name		—	—	K _I Pull-down	S ₀ /S ₁ Pull-down	—	S ₁ / $\overline{\text{LED}}$ mode	K _{I/O} mode	S ₀ mode
Set value	0	Fixed	Fixed	OFF	OFF	Fixed to "0"	S ₁	IN	OFF
	1	to "0"	to "0"	ON	ON		$\overline{\text{LED}}$	OUT	IN
When reset		0	0	1	0	0	1	1	0

b₀ : Specifies the input mode of the S₀ port. "0" = OFF mode (high impedance); "1" = IN (INPUT mode).

b₁ : Specifies the I/O mode of the K_{I/O} port.

"0" = IN (INPUT mode); "1" = OUT (OUTPUT mode).

b₂ : Specifies the I/O mode of the S₁/ $\overline{\text{LED}}$ port. "0" = S₁ (INPUT mode); "1" = $\overline{\text{LED}}$ (output mode).

b₄ : Specifies the availability of the pull-down resistor in S₀/S₁ port INPUT mode. "0" = OFF (unavailable);

"1" = ON (available)

b₅ : Specifies the availability of the pull-down resistor in K_I port. "0" = OFF (unavailable);

"1" = ON (available).

Remark In OUTPUT mode or in OFF mode, all the pull-down resistors are automatically disconnected.

4. TIMER

4.1 Timer Configuration

The timer is the block used for creating a remote control transmission pattern. As shown in Figure 4-1, it consists of a 9-bit down counter (t_8 to t_0), a flag (t_9) permitting the 1-bit timer output, and a zero detecting circuit.

Figure 4-1. Timer Configuration

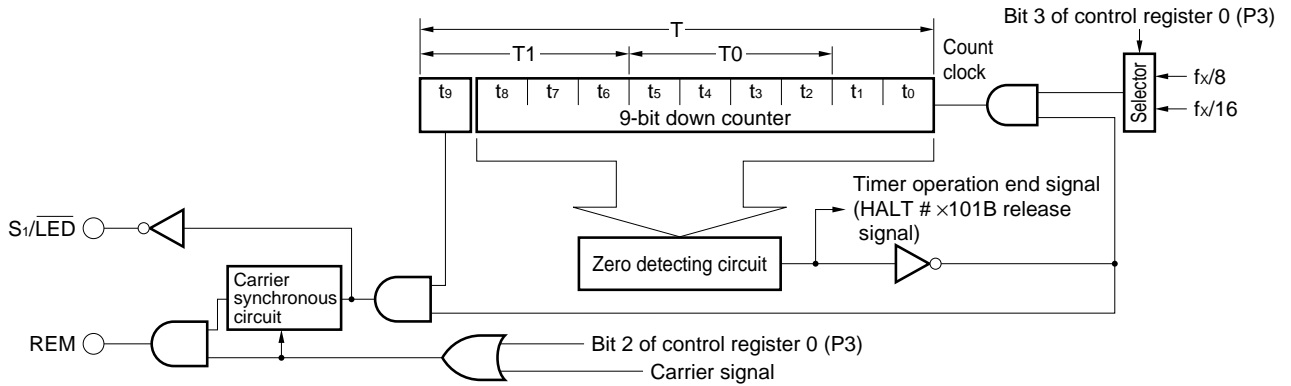

4.2 Timer Operation

The timer starts (counting down) when a value other than 0 is set for the down counter with a timer operation instruction. The timer operation instructions for making the timer start operation are shown below:

```
MOV T0, A
MOV T1, A
MOV T, #data10
MOV T, @R0
```

The down counter is decremented (-1) in the cycle of 8/fx or 16/fx^{Note}. If the value of the down counter becomes 0, the zero detecting circuit generates the timer operation end signal to stop the timer operation. At this time, if the timer is in HALT mode (HALT # × 101B) waiting for the timer to stop its operation, the HALT mode is canceled and the instruction following the HALT instruction is executed. The output of the timer operation end signal is continued while the down counter is 0 and the timer is stopped. There is the following relational expression between the timer's time and the down counter's set value.

$$\text{Timer time} = (\text{Set value} + 1) \times 8/fx \text{ (or } 16/fx^{\text{Note}})$$

Note This becomes 16/fx if bit 3 of the control register is set (to 1).

By setting 1 for the flag (t₉) which enables the timer output, the timer can output its operation status from the S₁/LED pin and the REM pin. The REM pin can also output the carrier while the timer is in operation.

Table 4-1. Timer Output (at t₉ = 1)

	S ₁ /LED Pin	REM Pin
Timer operating	L	H (or carrier output ^{Note})
Timer halting	H	L

Note The carrier output results if bit 2 of the control register 0 is cleared (to 0).

Figure 4-2. Timer Output (When Carrier Is Not Output)

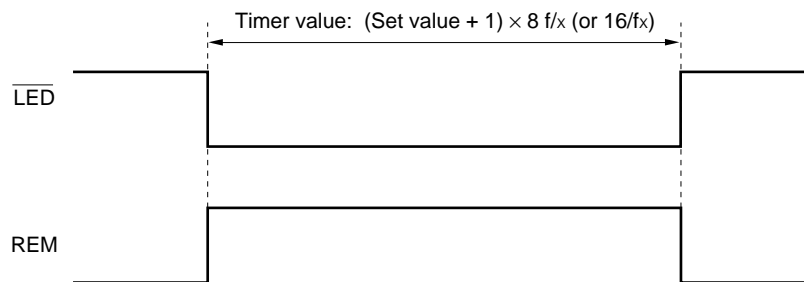

4.3 Carrier Output

The carrier for remote-controlled transmission can be output from the REM pin by clearing (to 0) bit 2 of the control register 0.

As shown in Figure 4-3, in the case where the timer stops when the carrier is at a high level, the carrier continues to be output until its next fall and then stops due to the function of the carrier synchronous circuit. When the timer starts operation, however, the high-level width of the first carrier may become shorter than the specified width.

Figure 4-3. Timer Output (When Carrier Is Output)

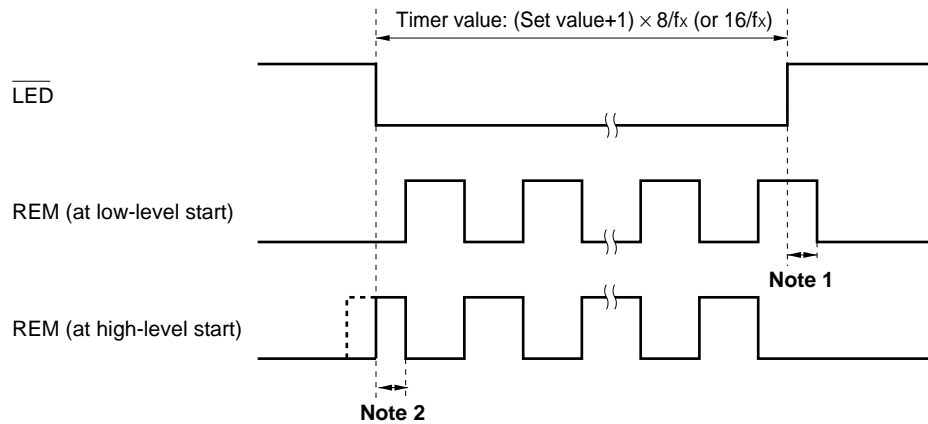

- Notes**
1. Error when the REM output ends: Lead by “the carrier’s low-level width” to lag by “the carrier’s high-level width”
 2. Error of the carrier’s high-level width: 0 to “the carrier’s high-level width”

4.4 Software Control of Timer Output

The timer output can be controlled by software. As shown in Figure 4-4, the pulse with a minimum width of 1-instruction cycle ($8/f_x$) can be output.

Figure 4-4. Pulse Output of 1-Instruction Cycle Width

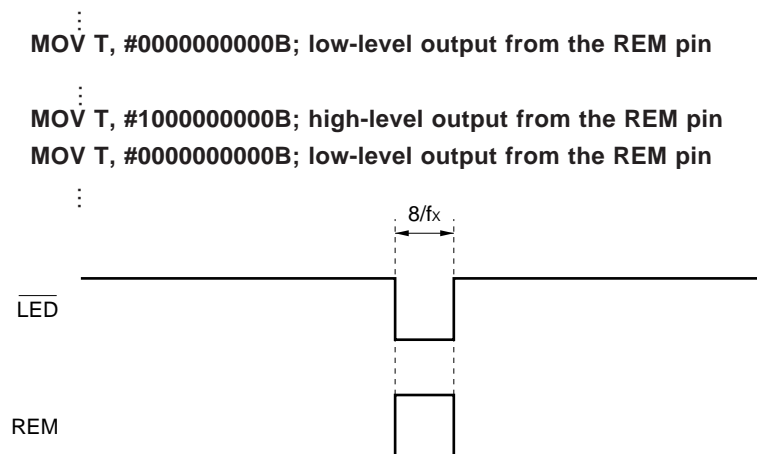

5. STANDBY FUNCTION

5.1 Outline of Standby Function

To save current consumption, two types of standby modes, i.e., HALT mode and STOP mode, are made available.

In STOP mode, the system clock stops oscillation. At this time, the X_{IN} and X_{OUT} pins are fixed at a low level.

In HALT mode, CPU operation halts, while the system clock continues oscillation. When in HALT mode, the timer (including REM output and LED output) operates.

In either STOP mode or HALT mode, the statuses of the data memory, accumulator, and port register, etc. immediately before the standby mode is set are retained. Therefore, make sure to set the port status for the system so that the current consumption of the whole system is suppressed before the standby mode is set.

Table 5-1. Statuses During Standby Mode

		STOP Mode	HALT Mode	
Setting instruction		HALT instruction		
Clock oscillator		Oscillation stopped	Oscillation continued	
Operation statuses	CPU	• Operation halted		
	Data memory	• Immediately preceding status retained		
	Accumulator	• Immediately preceding status retained		
	Flag	F	• 0 (When 1, the flag is not placed in the standby mode.)	
		CY	• Immediately preceding status retained	
	Port register	• Immediately preceding status retained		
Timer	• Operation halted (The count value is reset to "0")	• Operable		

- Cautions**
1. Write the NOP instruction as the first instruction after STOP mode is canceled.
 2. When standby mode is canceled, the status flag (F) is set (to 1).
 3. If, at the point the standby mode has been set, its cancelation condition is met, then the system is not placed in the standby mode. However, the status flag (F) is set (1).

5.2 Standby Mode Setup and Cancelation

The standby mode is set with the HALT #b3b2b1b0B instruction for both STOP mode and HALT mode. For the standby mode to be set, the status flag (F) is required to have been cleared (to 0).

The standby mode is canceled by the cancelation condition specified with the $\overline{\text{RESET}}$ ($\overline{\text{RESET}}$ input; POC) or the operand of HALT instruction. If the standby mode is canceled, the status flag (F) is set (to 1).

Even when the HALT instruction is executed in the state that the status flag (F) has been set (to 1), the standby mode is not set. If the cancelation condition is not met at this time, the status flag is cleared (to 0). If the cancelation condition is met, the status flag remains set (to 1).

Even in the case when the cancelation condition has been already met at the point that the HALT instruction is executed, the standby mode is not set. Here, also, the status flag (F) is set (to 1).

Caution Depending on the status of the status flag (F), the HALT instruction may not be executed. Be careful about this. For example, when setting HALT mode after checking the key status with the STTS instruction, the system does not enter HALT mode as long as the status flag (F) remains set (to 1) thus sometimes performing an unintended operation. In this case, the intended operation can be realized by executing the STTS instruction immediately after timer setting to clear (to 0) the status flag.

```

Example  STTS    #03H    ;To check the Ki pin status.
           :
           MOV     T, #0xxH ;To set the timer
           STTS    #05H    ;To clear the status flag
           : (During this time, be sure not to execute an instruction that may set the status flag.)
           HALT   #05H    ;To set HALT mode
    
```

Table 5-2. Addresses Executed After Standby Mode Release

Cancelation Condition	Address Executed After Cancelation
Reset	0 address
Cancelation condition shown in Table 5-3	The address following the HALT instruction

Table 5-3. Standby Mode Setup (HALT #b3b2b1b0B) and Release Conditions

Operand Value of HALT Instruction				Setting Mode	Precondition for Setup	Release Condition
b3	b2	b1	b0			
0	0	0	0	STOP	All K _{I/O} pins are high-level output.	High level is input to at least one of K _I pins.
	0	1	1	STOP	All K _{I/O} pins are high-level output.	High level is input to at least one of K _I pins.
	1	1	0	STOP ^{Note 1}	The K _{I/O0} pin is high-level output.	High level is input to at least one of K _I pins.
1	Any of the combinations of b2b1b0 above			STOP or HALT	[The following condition is added in addition to the above.] —	High level is input to at least one of S ₀ and S ₁ pins ^{Note 2} .
0/1	1	0	1	HALT	—	When the timer's down counter is 0

- Notes**
1. When setting HALT #×110B, configure a key matrix by using the K_{I/O0} pin and the K_I pin so that an internal reset takes effect at the time of program hang-up.
 2. At least one of the S₀ and S₁ pins (the pin used for releasing the standby) must be in INPUT mode. (The internal reset does not take effect even when both pins are in OUTPUT mode.)

- Cautions**
1. The internal reset takes effect when the HALT instruction is executed with an operand value other than that above or when the precondition has not been satisfied when executing the HALT instruction.
 2. If STOP mode is set when the timer's down counter is not 0 (timer operating), the system is placed in STOP mode only after all the 10 bits of the timer's down counter and the timer output permit flag are cleared to 0.
 3. Write the NOP instruction as the first instruction after STOP mode is released.

5.3 Standby Mode Release Timing

(1) STOP Mode Release Timing

Figure 5-1. STOP Mode Cancelation by Release Condition

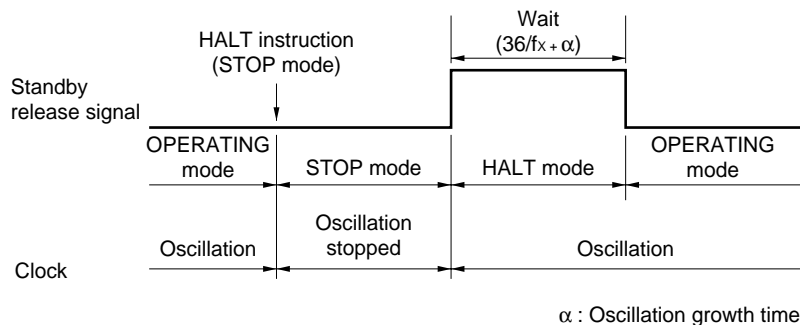

Caution When a release condition is established in the STOP mode, the device is released from the STOP mode and goes into a wait status. At this time, if the release condition is not held, the device mode and goes into the STOP mode again after the wait time has elapsed. Therefore, when releasing the STOP mode, it is necessary to hold the release condition longer than the wait time.

Figure 5-2. STOP Mode Release by $\overline{\text{RESET}}$ Input

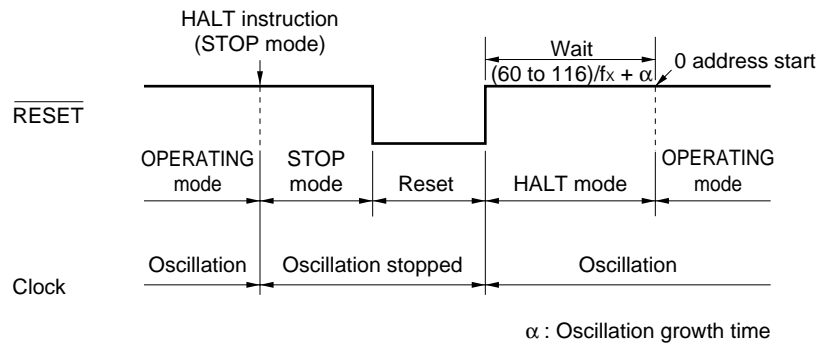

(2) HALT Mode Release Timing

Figure 5-3. HALT Mode Release by Cancellation Condition

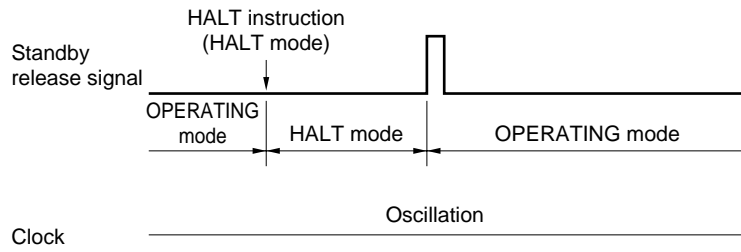
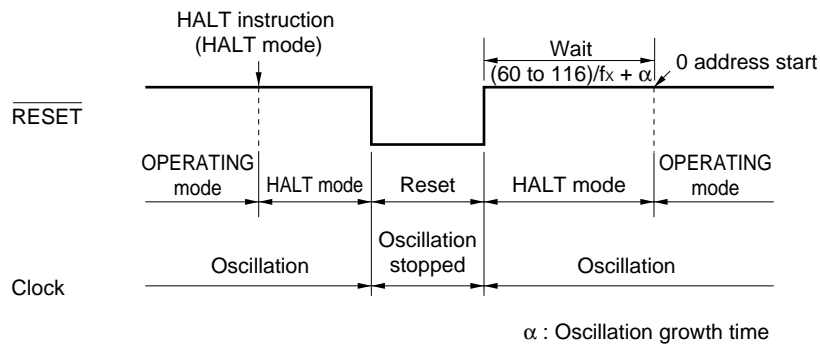

Figure 5-4. HALT Mode Release by $\overline{\text{RESET}}$ Input



6. RESET PIN

The system reset takes effect by inputting low level to the RESET pin.

While the RESET pin is at low level, the system clock oscillator is stopped and the X_{IN} and X_{OUT} pins are fixed to the GND.

If the RESET pin is raised from low level to high level, it executes the program from the 0 address after counting 60 to 116 of the system clock (f_x).

Figure 6-1. Reset Operation by RESET Input

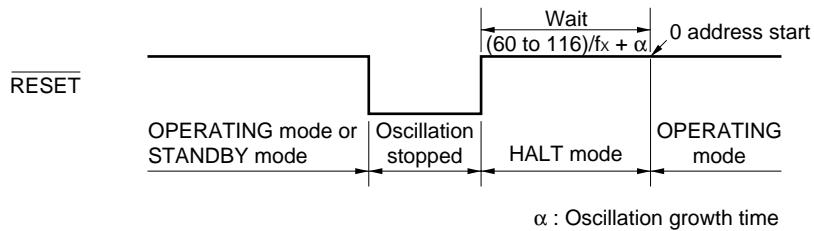

The RESET pin outputs low level when the POC circuit (mask option) is in operation.

Caution When connecting a reset IC to the RESET pin, ensure that the IC is of the N-ch open drain output type.

Table 6-1. Hardware Statuses After Reset

Hardware		<ul style="list-style-type: none"> • RESET Input in Operation • Resetting by Internal POC Circuit in Operation • Resetting by Other Factors^{Note 1} 	<ul style="list-style-type: none"> • RESET Input During STANDBY Mode • Resetting by the Internal POC Circuit During STANDBY Mode
PC (10 bits)		000H	
SP (1 bit)		0B	
Data memory	R0 = DP	000H	
	R1-RF	Undefined	Previous status retained
Accumulator (A)		Undefined	
Status flag (F)		0B	
Carry flag (CY)		0B	
Timer (10 bits)		000H	
Port register	P0	FFH	
	P1	xFH ^{Note 2}	
Control register	P3	03H	
	P4	26H	

Notes 1. The following resets are available.

- Reset when executing the HALT instruction (when the operand value is illegal or does not satisfy the precondition)
- Reset when executing the RLZ instruction (when A = 0)
- Reset by stack pointer's overflow or underflow

2. Refers to the value by the K_i pin status.

In order to prevent malfunction, be sure to input a low level to more than one of pins K₁₀ to K₁₃ when reset is released (when RESET pin changes from low level to high level, or POC is released due to supply voltage startup).

7. POC CIRCUIT (MASK OPTION)

The POC circuit monitors the power supply voltage and applies an internal reset in the microcontroller at the time of battery replacement. If the applied circuit satisfies the following conditions, the POC circuit can be incorporated by the mask option.

- High reliability is not required.
- Clock frequency $f_x = 300$ to 500 kHz
- Operating ambient temperature $T_A = -20$ to $+70$ °C

Cautions 1. The one-time PROM product (μ PD61P34B) originally contains the POC circuit.

2. There are cases in which the POC circuit cannot detect a low power supply voltage of less than 1 ms. Therefore, if the power supply voltage has become low for a period of less than 1 ms, the POC circuit may malfunction because it does not generate an internal reset signal.
3. Clock oscillation is stopped by the resonator due to low power supply voltage before the POC circuit generates the internal reset signal. In this case, malfunction may result, for example when the power supply voltage is recovered after the oscillation is stopped. This type of phenomenon takes place because the POC circuit does not generate an internal reset signal (because the power supply voltage recovers before the low power supply voltage is detected) even though the clock has stopped. If, by any chance, a malfunction has taken place, remove the battery for a short time and put it back. In most cases, normal operation will be resumed.
4. If the applied circuit does not satisfy the conditions above, design the applied circuit in such a manner that the reset takes effect without failure within the power supply voltage range by means of an external reset circuit.
5. In order to prevent malfunction, be sure to input a low level to more than one of pins K_{10} to K_{13} when reset is released (when $\overline{\text{RESET}}$ pin changes from low level to high level, or POC is released due to supply voltage startup).

Remarks 1. It is recommended that a POC circuit should be incorporated if applied circuits are infrared remote-control transmitters for household appliances.

2. Even when a POC circuit is incorporated, the externally entered $\overline{\text{RESET}}$ input is valid with the OR condition; therefore, the POC circuit and the $\overline{\text{RESET}}$ input can be used at the same time. However, if the POC circuit detects a low power supply voltage, the $\overline{\text{RESET}}$ pin will be forced to low level; therefore, use an N-ch open drain output or NPN open collector output for the external reset circuit.

7.1 Functions of POC Circuit

The POC circuit has the following functions:

- Generates an internal reset signal when $V_{DD} \leq V_{POC}$.
- Cancels an internal reset signal when $V_{DD} > V_{POC}$.

Here, V_{DD} : power supply voltage, V_{POC} : POC-detected voltage.

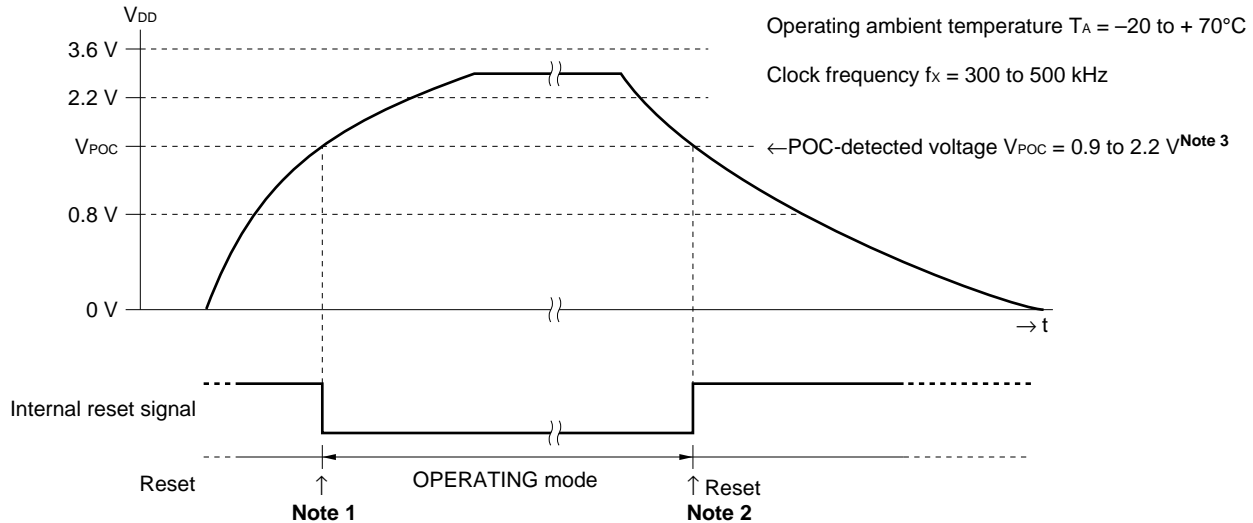

- Notes**
1. In reality, there is the oscillation stabilization wait time until the circuit is switched to OPERATING mode. The oscillation stabilization wait time is about $60/f_x$ to $116/f_x$ (when about 130 to 250 μs ; $f_x = 455$ kHz).
 2. For the POC circuit to generate an internal reset signal when the power supply voltage has fallen, it is necessary for the power supply voltage to be kept less than the V_{POC} for the period of 1 ms or more. Therefore, in reality, there is the time lag of up to 1 ms until the reset takes effect.
 3. The POC-detected voltage (V_{POC}) varies between 0.9 to 2.2 V; thus, the resetting may be canceled at a power supply voltage smaller than the assured range ($V_{DD} = 1.8$ to 3.6 V). However, as long as the conditions for operating the POC circuit are met, the actual lowest operating power supply voltage becomes lower than the POC-detected voltage. Therefore, there is no malfunction occurring due to the shortage of power supply voltage. However, malfunction for such reasons as the clock not oscillating due to low power supply voltage may occur (refer to **Cautions 3.** in **7. POC CIRCUIT**).

7.2 Oscillation Check at Low Supply Voltage

A reliable resetting operation can be expected of the POC circuit if it satisfies the condition that the clock can oscillate even at low power supply voltage (the oscillation start voltage of the resonator being even lower than the POC-detected voltage). Whether this condition is being met or not can be checked by measuring the oscillation status on a product which actually contains a POC circuit, as follows.

- <1> Connect a storage oscilloscope to the X_{OUT} pin so that the oscillation status can be measured.
- <2> Connect a power supply whose output voltage can be varied and then gradually raise the power supply voltage V_{DD} from 0 V (making sure to avoid $V_{DD} > 3.6\text{V}$).

At first (during $V_{DD} < 0.9$ V), the X_{OUT} pin is 0 V regardless of the V_{DD} . However, at the point that V_{DD} reaches the POC-detected voltage (voltage somewhere between $V_{POC} = 0.9$ to 2.2 V), the voltage of the X_{OUT} pin jumps to about $0.5 V_{DD}$. Maintain this power supply voltage for a while to measure the waveform of the X_{OUT} pin. If, by any chance, the oscillation start voltage of the resonator is lower than the POC-detected voltage, the growing oscillation of the X_{OUT} pin can be confirmed within several ms after the V_{DD} has reached the V_{POC} .

8. SYSTEM CLOCK OSCILLATOR

The system clock oscillator consists of oscillators for ceramic resonators ($f_x = 300 \text{ kHz to } 1 \text{ MHz}$).

Figure 8-1. System Clock

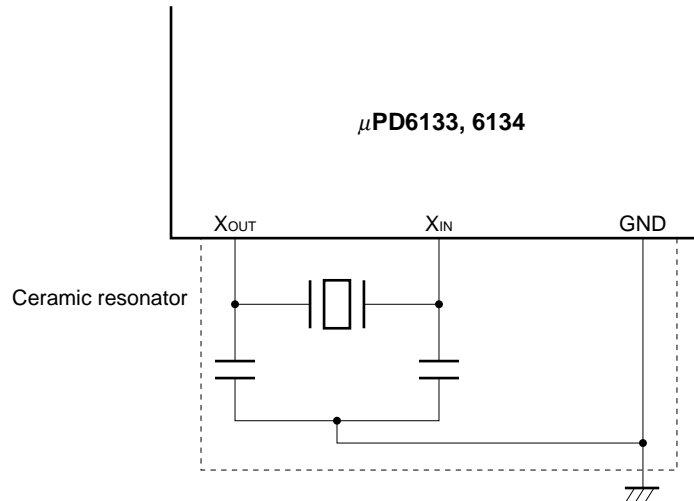

The system clock oscillator stops its oscillation when reset or in STOP mode.

Caution When using the system clock oscillator, wire area indicated by the dotted-line in the diagram as follows to reduce the effects of the wiring capacitance, etc.

- Make the wiring as short as possible.
- Do not allow the wiring to intersect other signal lines. Do not wire close to lines through which large fluctuating currents flow.
- Make sure that the point where the oscillator capacitor is installed is always at the same electric potential as the ground. Never earth with a ground pattern through which large currents flow.
- Do not extract signals from the oscillator.

9. INSTRUCTION SET

9.1 Machine Language Output by Assembler

The bit length of the machine language of this product is 10 bits per word. However, the machine language that is output by the assembler is extended to 16 bits per word. As shown in the example below, the expansion is made by inserting 3-bit extended bits (111) in two locations.

Figure 9-1. Example of Assembler Output (10 bits extended to 16 bits)

<1> In the case of "ANL A, @R0H"

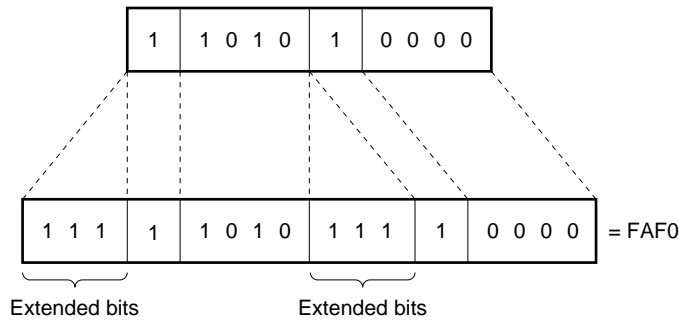

<2> In the case of "OUT P0, #data8"

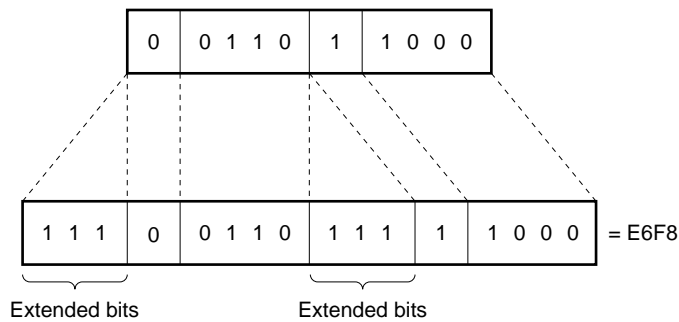

9.2 Circuit Symbol Description

A	: Accumulator
ASR	: Address Stack Register
addr	: Program memory address
CY	: Carry flag
data4	: 4-bit immediate data
data8	: 8-bit immediate data
data10	: 10-bit immediate data
F	: Status flag
PC	: Program Counter
Pn	: Port register pair (n = 0, 1, 3, 4)
P0n	: Port register (low-order 4 bits)
P1n	: Port register (high-order 4 bits)
ROMn	: Bit n of the program memory's (n = 0-9)
Rn	: Register pair
R0n	: Data memory (General-purpose register; n = 0-F)
R1n	: Data memory (General-purpose register; n = 0-F)
SP	: Stack Pointer
T	: Timer register
T0	: Timer register (low-order 4 bits)
T1	: Timer register (high-order 4 bits)
(\times)	: Content addressed with \times

9.3 Mnemonic to/from Machine Language (Assembler Output) Contrast Table

Accumulator Operation Instructions

Mnemonic	Operand	Instruction Code			Operation	Instruction Length	Instruction Cycle
		1st Word	2nd Word	3rd Word			
ANL	A, R0n	FBE _n			$(A) \leftarrow (A) \wedge (R_{mn}) \quad m = 0, 1 \quad n = 0-F$	1	1
	A, R1n	FAE _n			$CY \leftarrow A_3 \cdot R_{mn3}$		
	A, @R0H	FAF0			$(A) \leftarrow (A) \wedge ((P13), (R0))_{7-4}$ $CY \leftarrow A_3 \cdot ROM_7$		
	A, @R0L	FBF0			$(A) \leftarrow (A) \wedge ((P13), (R0))_{3-0}$ $CY \leftarrow A_3 \cdot ROM_3$		
	A, #data4	FBF1	data4		$(A) \leftarrow (A) \wedge data4$ $CY \leftarrow A_3 \cdot data4_3$	2	
ORL	A, R0n	FDE _n			$(A) \leftarrow (A) \vee (R_{mn}) \quad m = 0, 1 \quad n = 0-F$	1	
	A, R1n	FCE _n			$CY \leftarrow 0$		
	A, @R0H	FCF0			$(A) \leftarrow (A) \vee ((P13), (R0))_{7-4}$ $CY \leftarrow 0$		
	A, @R0L	FDF0			$(A) \leftarrow (A) \vee ((P13), (R0))_{3-0}$ $CY \leftarrow 0$		
	A, #data4	FDF1	data4		$(A) \leftarrow (A) \vee data4$ $CY \leftarrow 0$	2	
XRL	A, R0n	F5E _n			$(A) \leftarrow (A) \nabla (R_{mn}) \quad m = 0, 1 \quad n = 0-F$	1	
	A, R1n	F4E _n			$CY \leftarrow A_3 \cdot R_{mn3}$		
	A, @R0H	F4F0			$(A) \leftarrow (A) \nabla ((P13), (R0))_{7-4}$ $CY \leftarrow A_3 \cdot ROM_7$		
	A, @R0L	F5F0			$(A) \leftarrow (A) \nabla ((P13), (R0))_{3-0}$ $CY \leftarrow A_3 \cdot ROM_3$		
	A, #data4	F5F1	data4		$(A) \leftarrow (A) \nabla data4$ $CY \leftarrow A_3 \cdot data4_3$	2	
INC	A	F4F3			$(A) \leftarrow (A) + 1$ if (A) = 0 CY ← 1 else CY ← 1	1	
RL	A	FCF3			$(A_{n+1}) \leftarrow (A_n), (A_0) \leftarrow (A_3)$ $CY \leftarrow A_3$		
RLZ	A	FEF3			if A = 0 reset else $(A_{n+1}) \leftarrow (A_n), (A_0) \leftarrow (A_3)$ $CY \leftarrow A_3$		

Input/output Instructions

Mnemonic	Operand	Instruction Code			Operation	Instruction Length	Instruction Cycle
		1st Word	2nd Word	3rd Word			
IN	A, P0n	FFF8 + n	—	—	(A) ← (Pmn) m = 0, 1 n = 0, 1, 3, 4	1	1
	A, P1n	FEF8 + n	—	—	CY ← 0		
OUT	P0n, A	E5F8 + n	—	—	(Pmn) ← (A) m = 0, 1 n = 0, 1, 3, 4	1	1
	P1n, A	E4F8 + n	—	—			
ANL	A, P0n	FBF8 + n	—	—	(A) ← (A) ∧ (Pmn) m = 0, 1 n = 0, 1, 3, 4	1	1
	A, P1n	FAF8 + n	—	—	CY ← A ₃ • Pmn ₃		
ORL	A, P0n	fdf8 + n	—	—	(A) ← (A) ∨ (Pmn) m = 0, 1 n = 0, 1, 3, 4	1	1
	A, P1n	FCF8 + n	—	—	CY ← 0		
XRL	A, P0n	F5F8 + n	—	—	(A) ← (A) ⊕ (Pmn) m = 0, 1 n = 0, 1, 3, 4	1	1
	A, P1n	F4F8 + n	—	—	CY ← A ₃ • Pmn ₃		

Mnemonic	Operand	Instruction Code			Operation	Instruction Length	Instruction Cycle
		1st Word	2nd Word	3rd Word			
OUT	Pn, #data8	E6F8 + n	data8		(Pn) ← data8 n = 0, 1, 3, 4	2	1

Remark Pn: P1n-P0n are dealt with in pairs.

Data Transfer Instruction

Mnemonic	Operand	Instruction Code			Operation	Instruction Length	Instruction Cycle
		1st Word	2nd Word	3rd Word			
MOV	A, R0n	FFEn			(A) ← (Rmn) m = 0, 1 n = 0-F	1	1
	A, R1n	FEEEn			CY ← 0		
	A, @R0H	FEF0			(A) ← ((P13), (R0)) ₇₋₄ CY ← 0		
	A, @R0L	FFF0			(A) ← ((P13), (R0)) ₇₋₄ CY ← 0	2	1
	A, #data4	FFF1	data4		(A) ← data4 CY ← 0		
	R0n, A	E5En			(Rmn) ← (A) m = 0, 1 n = 0-F	1	1
	R1n, A	E4En					

Mnemonic	Operand	Instruction Code			Operation	Instruction Length	Instruction Cycle
		1st Word	2nd Word	3rd Word			
MOV	Rn, #data8	E6En	data8	—	(R1n-R0n) ← data8 n = 0-F	2	1
	Rn, @R0	E7En	—	—	(R1n-R0n) ← ((P13), (R0)) n = 1-F		

Remark Rn: R1n-R0n are dealt with in pairs.

Branch Instructions

Mnemonic	Operand	Instruction Code			Operation	Instruction Length	Instruction Cycle
		1st Word	2nd Word	3rd Word			
JMP	addr (Page 0)	E8F1	addr		PC ← addr	2	1
	addr (Page 1)	E9F1	addr				
JC	addr (Page 0)	ECF1	addr		if CY = 1 PC ← addr	2	1
	addr (Page 1)	EAF1	addr		else PC ← PC + 2		
JNC	addr (Page 0)	EDF1	addr		if CY = 0 PC ← addr	2	1
	addr (Page 1)	EBF1	addr		else PC ← PC + 2		
JF	addr (Page 0)	EEF1	addr		if F = 1 PC ← addr	2	1
	addr (Page 1)	F0F1	addr		else PC ← PC + 2		
JNF	addr (Page 0)	EFF1	addr		if F = 0 PC ← addr	2	1
	addr (Page 1)	F1F1	addr		else PC ← PC + 2		

Caution 0 and 1, which refer to PAGE0 and 1, are not written when describing mnemonics.

Subroutine Instructions

Mnemonic	Operand	Instruction Code			Operation	Instruction Length	Instruction Cycle
		1st Word	2nd Word	3rd Word			
CALL	addr (Page 0)	E6F2	E8F1	addr	SP ← SP + 1, ASR ← PC, PC ← addr	3	2
	addr (Page 1)	E6F2	E9F1	addr			
RET		E8F2			PC ← ASR, SP ← SP - 1	1	1

Caution 0 and 1, which refer to PAGE0 and 1, are not written when describing mnemonics.

Timer Operation Instructions

Mnemonic	Operand	Instruction Code			Operation	Instruction Length	Instruction Cycle
		1st Word	2nd Word	3rd Word			
MOV	A, T0	FFFF			(A) ← (Tn) n = 0, 1	1	1
	A, T1	FEFF			CY ← 0		
	T0, A	E5FF			(Tn) ← (A) n = 0, 1		
	T1, A	F4FF			(T) n ← 0		

Mnemonic	Operand	Instruction Code			Operation	Instruction Length	Instruction Cycle
		1st Word	2nd Word	3rd Word			
MOV	T, #data10	E6FF	data10		(T) ← data10	1	1
	T, @R0	F4FF			(T) ← ((P13), (R0))		

Others

Mnemonic	Operand	Instruction Code			Operation	Instruction Length	Instruction Cycle
		1st Word	2nd Word	3rd Word			
HALT	#data4	E2F1	data4		Standby mode	2	1
STTS	#data4	E3F1	data4		if statuses match $F \leftarrow 1$ else $F \leftarrow 0$		
	R0n	E3En			if statuses match $F \leftarrow 1$ else $F \leftarrow 0$ $n = 0-F$	1	
SCAF		FAF3			if A = 0FH $CY \leftarrow 1$ else $CY \leftarrow 0$		
NOP		E0E0			$PC \leftarrow PC + 1$		

9.4 Accumulator Operation Instructions

ANL A, R0n

ANL A, R1n

- <1> Instruction code :

1	1	0	1	R ₄	0	R ₃	R ₂	R ₁	R ₀
---	---	---	---	----------------	---	----------------	----------------	----------------	----------------
- <2> Cycle count : 1
- <3> Function : $(A) \leftarrow (A) \wedge (R_{mn})$ $m = 0, 1$ $n = 0$ to F
CY $\leftarrow A_3 \cdot R_{mn3}$

The accumulator contents and the register Rmn contents are ANDed and the results are entered in the accumulator.

ANL A, @R0H

ANL A, @R0L

- <1> Instruction code :

1	1	0	1	0	1	1	0	0	0	0
---	---	---	---	---	---	---	---	---	---	---
- <2> Cycle count : 1
- <3> Function : $(A) \leftarrow (A) \wedge ((P13), (R0))_{7-4}$ (in the case of ANL A, @R0H)
CY $\leftarrow A_3 \cdot ROM_7$
 $(A) \leftarrow (A) \wedge ((P13), (R0))_{3-0}$ (in the case of ANL A, @R0L)
CY $\leftarrow A_3 \cdot ROM_3$

The accumulator contents and the program memory contents specified with the control register P13 and register pair R10-R00 are ANDed and the results are entered in the accumulator.

If H is specified, b₇, b₆, b₅ and b₄ take effect. If L is specified, b₃, b₂, b₁ and b₀ take effect.

- **Program memory (ROM) organization**

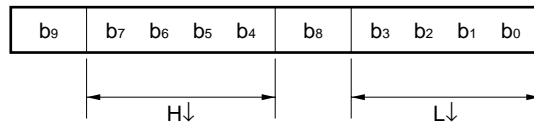

Valid bits at the time of accumulator operation

ANL A, #data4

- <1> Instruction code :

1	1	0	1	1	1	0	0	0	1
0	0	0	0	0	0	d ₃	d ₂	d ₁	d ₀
- <2> Cycle count : 1
- <3> Function : $(A) \leftarrow (A) \wedge \text{data4}$
CY $\leftarrow A_3 \cdot \text{data4}_3$

The accumulator contents and the immediate data are ANDed and the results are entered in the accumulator.

ORL A, R0n

ORL A, R1n

- <1> Instruction code :

1	1	1	0	R ₄	0	R ₃	R ₂	R ₁	R ₀
---	---	---	---	----------------	---	----------------	----------------	----------------	----------------
- <2> Cycle count : 1
- <3> Function : $(A) \leftarrow (A) \vee (Rmn)$ $m = 0, 1$ $n = 0$ to F
CY ← 0

The accumulator contents and the register Rmn contents are ORed and the results are entered in the accumulator.

ORL A, @R0H

ORL A, @R0L

- <1> Instruction code :

1	1	1	0	0	1	1	0	0	0	0
---	---	---	---	---	---	---	---	---	---	---
- <2> Cycle count : 1
- <3> Function : $(A) \leftarrow (A) \vee (P13), (R0))_{7-4}$ (in the case of ORL A, @R0H)
 $(A) \leftarrow (A) \vee (P13), (R0))_{3-0}$ (in the case of ORL A, @R0L)
CY ← 0

The accumulator contents and the program memory contents specified with the control register P13 and register pair R₁₀-R₀₀ are ORed and the results are entered in the accumulator.

If H is specified, b₇, b₆, b₅ and b₄ take effect. If L is specified, b₃, b₂, b₁ and b₀ take effect.

ORL A, #data4

- <1> Instruction code :

1	1	1	0	1	1	0	0	0	1
0	0	0	0	0	0	d ₃	d ₂	d ₁	d ₀
- <2> Cycle count : 1
- <3> Function : $(A) \leftarrow (A) \vee \text{data4}$
CY ← 0

The accumulator contents and the immediate data are exclusive-ORed and the results are entered in the accumulator.

XRL A, R0n

XRL A, R1n

- <1> Instruction code :

1	0	1	0	R ₄	0	R ₃	R ₂	R ₁	R ₀
---	---	---	---	----------------	---	----------------	----------------	----------------	----------------
- <2> Cycle count : 1
- <3> Function : $(A) \leftarrow (A) \nabla (Rmn)$ $m = 0, 1$ $n = 0$ to F
CY ← A₃ • Rmn₃

The accumulator contents and the register Rmn contents are ORed and the results are entered in the accumulator.

XRL A, @R0H

XRL A, @R0L

<1> Instruction code :

1	0	1	0	0	1	1	0	0	0	0
---	---	---	---	---	---	---	---	---	---	---

<2> Cycle count : 1

<3> Function : $(A) \leftarrow (A) \vee (P13), (R0))_{7-4}$ (in the case of XRL A, @R0H)

$CY \leftarrow A_3 \cdot ROM_7$

$(A) \leftarrow (A) \vee (P13), (R0))_{3-0}$ (in the case of XRL A, @R0L)

$CY \leftarrow A_3 \cdot ROM_3$

The accumulator contents and the program memory contents specified with the control register P13 and register pair R₁₀-R₀₀ are exclusive-ORed and the results are entered in the accumulator.

If H is specified, b₇, b₆, b₅, and b₄ take effect. If L is specified, b₃, b₂, b₁, and b₀ take effect.

XRL A, #data4

<1> Instruction code :

1	0	1	0	1	1	0	0	0	1
0	0	0	0	0	0	d ₃	d ₂	d ₁	d ₀

<2> Cycle count : 1

<3> Function : $(A) \leftarrow (A) \vee \text{data4}$

$CY \leftarrow A_3 \cdot \text{data4}_3$

The accumulator contents and the immediate data are exclusive-ORed and the results are entered in the accumulator.

INC A

<1> Instruction code :

1	0	1	0	0	1	0	0	1	1
---	---	---	---	---	---	---	---	---	---

<2> Cycle count : 1

<3> Function : $(A) \leftarrow (A) + 1$

if $A = 0$ $CY \leftarrow 1$

else $CY \leftarrow 0$

The accumulator contents are incremented (+1).

RL A

<1> Instruction code :

1	1	1	0	0	1	0	0	1	1
---	---	---	---	---	---	---	---	---	---

<2> Cycle count : 1

<3> Function : $(A_{n+1}) \leftarrow (A_n), (A_0) \leftarrow (A_3)$

$CY \leftarrow A_3$

The accumulator contents are rotated anticlockwise bit by bit.

RLZ A

<1> Instruction code :

1	1	1	1	0	1	0	0	1	1
---	---	---	---	---	---	---	---	---	---

<2> Cycle count : 1

<3> Function : if $A = 0$ reset

else $(A_{n+1}) \leftarrow (A_n), (A_0) \leftarrow (A_3)$

$CY \leftarrow A_3$

The accumulator contents are rotated anticlockwise bit by bit.

If $A = 0H$ at the time of command execution, an internal reset takes effect.

9.5 Input/Output Instructions

IN A, P0n

IN A, P1n

- <1> Instruction code :

1	1	1	1	P ₄	1	1	P ₂	P ₁	P ₀
---	---	---	---	----------------	---	---	----------------	----------------	----------------
- <2> Cycle count : 1
- <3> Function : $(A) \leftarrow (P_{mn}) \quad m = 0, 1 \quad n = 0, 1, 3, 4$
CY ← 0

The port P_{mn} data is loaded (read) onto the accumulator.

OUT P0n, A

OUT P1n, A

- <1> Instruction code :

0	0	1	0	P ₄	1	1	P ₂	P ₁	P ₀
---	---	---	---	----------------	---	---	----------------	----------------	----------------
- <2> Cycle count : 1
- <3> Function : $(P_{mn}) \leftarrow (A) \quad m = 0, 1 \quad n = 0, 1, 3, 4$

The accumulator contents are transferred to port P_{mn} to be latched.

ANL A, P0n

ANL A, P1n

- <1> Instruction code :

1	1	0	1	P ₄	1	1	P ₂	P ₁	P ₀
---	---	---	---	----------------	---	---	----------------	----------------	----------------
- <2> Cycle count : 1
- <3> Function : $(A) \leftarrow (A) \wedge (P_{mn}) \quad m = 0, 1 \quad n = 0, 1, 3, 4$
CY ← A₃ • P_{mn}

The accumulator contents and the port P_{mn} contents are ANDed and the results are entered in the accumulator.

ORL A, P0n

ORL A, P1n

- <1> Instruction code :

1	1	1	0	P ₄	1	1	P ₂	P ₁	P ₀
---	---	---	---	----------------	---	---	----------------	----------------	----------------
- <2> Cycle count : 1
- <3> Function : $(A) \leftarrow (A) \vee (P_{mn}) \quad m = 0, 1 \quad n = 0, 1, 3, 4$
CY ← 0

The accumulator contents and the port P_{mn} contents are ORed and the results are entered in the accumulator.

XRL A, P0n

XRL A, P1n

- <1> Instruction code :

1	0	1	0	P ₄	1	1	P ₂	P ₁	P ₀
---	---	---	---	----------------	---	---	----------------	----------------	----------------
- <2> Cycle count : 1
- <3> Function : $(A) \leftarrow (A) \nabla (P_{mn}) \quad m = 0, 1 \quad n = 0, 1, 3, 4$
CY ← A₃ • P_{mn}

The accumulator contents and the port P_{mn} contents are exclusive-ORed and the results are entered in the accumulator.

OUT Pn, #data8

<1> Instruction code :

0	0	1	1	0	1	1	P ₂	P ₁	P ₀
0	d ₇	d ₆	d ₅	d ₄	0	d ₃	d ₂	d ₁	d ₀

<2> Cycle count : 1

<3> Function : (Pn) ← data8 n = 0, 1, 3, 4

The immediate data is transferred to port Pn. In this case, port Pn refers to P_{1n}-P_{0n} operating in pairs.

9.6 Data Transfer Instructions

MOV A, R0n

MOV A, R1n

<1> Instruction code :

1	1	1	1	R ₄	0	R ₃	R ₂	R ₁	R ₀
---	---	---	---	----------------	---	----------------	----------------	----------------	----------------

<2> Cycle count : 1

<3> Function : (A) ← (Rmn) m = 0, 1 n = 0 to F
CY ← 0

The register Rmn contents are transferred to the accumulator.

MOV A, @R0H

<1> Instruction code :

1	1	1	1	0	1	0	0	0	0
---	---	---	---	---	---	---	---	---	---

<2> Cycle count : 1

<3> Function : (A) ← ((P13), (R0))₇₋₄
CY ← 0

The high-order 4 bits (b₇ b₆ b₅ b₄) of the program memory specified with control register P13 and register pair R₁₀-R₀₀ are transferred to the accumulator. b₉ is ignored.

MOV A, @R0L

<1> Instruction code :

1	1	1	1	1	1	0	0	0	0
---	---	---	---	---	---	---	---	---	---

<2> Cycle count : 1

<3> Function : (A) ← ((P13), (R0))₃₋₀
CY ← 0

The low-order 4 bits (b₃ b₂ b₁ b₀) of the program memory specified with control register P13 and register pair R₁₀-R₀₀ are transferred to the accumulator. b₈ is ignored.

• **Program memory (ROM) contents**

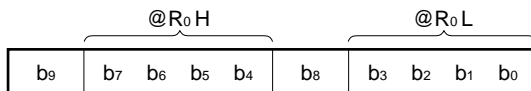

MOV A, #data4

<1> Instruction code :

1	1	1	1	1	1	0	0	0	1
0	0	0	0	0	0	d ₃	d ₂	d ₁	d ₀

<2> Cycle count : 1

<3> Function : (A) ← data4
CY ← 0

The immediate data is transferred to the accumulator.

MOV R0n, A

MOV R1n, A

<1> Instruction code :

0	0	1	0	R ₄	0	R ₃	R ₂	R ₁	R ₀
---	---	---	---	----------------	---	----------------	----------------	----------------	----------------

<2> Cycle count : 1

<3> Function : (R_mn) ← (A) m = 0, 1 n = 0 to F

The accumulator contents are transferred to register R_mn.

MOV Rn, #data8

<1> Instruction code :

0	0	1	1	0	0	R ₃	R ₂	R ₁	R ₀
0	d ₇	d ₆	d ₅	d ₄	0	d ₃	d ₂	d ₁	d ₀

<2> Cycle count : 1

<3> Function : (R₁n-R₀n) ← data8 n = 0-F

The immediate data is transferred to the register. Using this instruction, registers operate as register pairs.

The pair combinations are as follows:

R₀ : R₁₀ - R₀₀

R₁ : R₁₁ - R₀₁

:

R_E : R_{1E} - R_{0E}

R_F : R_{1F} - R_{0F}

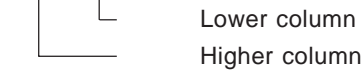

MOV Rn, @R0

<1> Instruction code :

0	0	1	1	1	0	R ₃	R ₂	R ₁	R ₀
---	---	---	---	---	---	----------------	----------------	----------------	----------------

<2> Cycle count : 1

<3> Function : (R₁n-R₀n) ← ((P13), R₀) n = 1 to F

The program memory contents specified with control register P13 and register pair R₁₀-R₀₀ are transferred to register pair R₁n-R₀n. The program memory consists of 10 bits and has the following state after the transfer to the register.

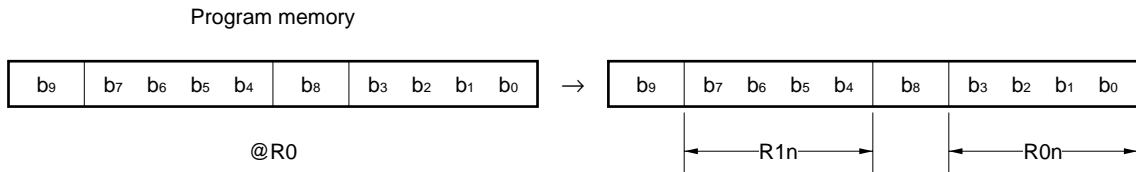

The high-order 2 bits of the program memory address is specified with the control register (P13).

9.7 Branch Instructions

The program memory consists of pages in steps of 1K (000H to 3FFH). However, as the assembler automatically performs page optimization, it is unnecessary to designate pages. The pages allowed for each product are as follows.

μ PD6133 (ROM: 0.5K steps) : page 0

μ PD6134 (ROM: 1K steps) : page 0

μ PD61P34B (ROM: 1K steps): page 0

JMP addr

<1> Instruction code : page 0

0	1	0	0	0	1	0	0	0	1
---	---	---	---	---	---	---	---	---	---

 ; page 1

0	1	0	0	1	1	0	0	0	1
---	---	---	---	---	---	---	---	---	---

a ₉	a ₇	a ₆	a ₅	a ₄	a ₃	a ₂	a ₁	a ₀
----------------	----------------	----------------	----------------	----------------	----------------	----------------	----------------	----------------

<2> Cycle count : 1

<3> Function : PC \leftarrow addr

The 10 bits (PC₉₋₀) of the program counter are replaced directly by the specified address addr (a₉ to a₀).

JC addr

<1> Instruction code : page 0

0	1	1	0	0	1	0	0	0	1
---	---	---	---	---	---	---	---	---	---

 ; page 1

0	1	0	1	0	1	0	0	0	1
---	---	---	---	---	---	---	---	---	---

a ₉	a ₇	a ₆	a ₅	a ₄	a ₃	a ₂	a ₁	a ₀
----------------	----------------	----------------	----------------	----------------	----------------	----------------	----------------	----------------

<2> Cycle count : 1

<3> Function : if CY = 1 PC \leftarrow addr
 else PC \leftarrow PC + 2

If the carry flag CY is set (to 1), a jump is made to the address specified with addr (a₉ to a₀).

JNC addr

<1> Instruction code : page 0

0	1	1	0	1	1	0	0	0	1
---	---	---	---	---	---	---	---	---	---

 ; page 1

0	1	0	1	1	1	0	0	0	1
---	---	---	---	---	---	---	---	---	---

a ₉	a ₇	a ₆	a ₅	a ₄	a ₃	a ₂	a ₁	a ₀
----------------	----------------	----------------	----------------	----------------	----------------	----------------	----------------	----------------

<2> Cycle count : 1

<3> Function : if CY = 0 PC \leftarrow addr
 else PC \leftarrow PC + 2

If the carry flag CY is cleared (to 0), a jump is made to the address specified with addr (a₉ to a₀).

JF addr

<1> Instruction code : page 0

0	1	1	1	0	1	0	0	0	1
---	---	---	---	---	---	---	---	---	---

 ; page 1

1	0	0	0	0	1	0	0	0	1
---	---	---	---	---	---	---	---	---	---

a ₉	a ₇	a ₆	a ₅	a ₄	a ₃	a ₂	a ₁	a ₀
----------------	----------------	----------------	----------------	----------------	----------------	----------------	----------------	----------------

<2> Cycle count : 1

<3> Function : if F = 1 PC \leftarrow addr
 else PC \leftarrow PC + 2

If the status flag F is set (to 1), a jump is made to the address specified with addr (a₉ to a₀).

JNF addr

<1> Instruction code : page 0

0	1	1	1	1	1	0	0	0	1
---	---	---	---	---	---	---	---	---	---

 ; page 1

1	0	0	0	1	1	0	0	0	1
---	---	---	---	---	---	---	---	---	---

a ₉	a ₇	a ₆	a ₅	a ₄	a ₃	a ₂	a ₁	a ₀
----------------	----------------	----------------	----------------	----------------	----------------	----------------	----------------	----------------

<2> Cycle count : 1

<3> Function : if F = 0 PC \leftarrow addr
 else PC \leftarrow PC + 2

If the status flag F is cleared (to 0), a jump is made to the address specified with addr (a₉ to a₀).

9.8 Subroutine Instructions

The program memory consists of pages in steps of 1K (000H to 3FFH). However, as the assembler automatically performs page optimization, it is unnecessary to designate pages. The pages allowed for each product are as follows.

- μPD6133 (ROM: 0.5K steps) : page 0
- μPD6134 (ROM: 1K steps) : page 0
- μPD61P34B (ROM: 1K steps): page 0

CALL addr

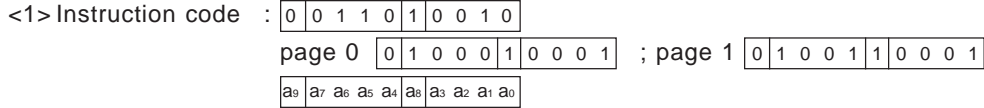

- <2> Cycle count : 2
- <3> Function : SP ← SP + 1
ASR ← PC
PC ← addr

Increments (+1) the stack pointer value and saves the program counter value in the address stack register. Then, enters the address specified with the operand addr (a₉ to a₀) into the program counter. If a carry is generated when the stack pointer value is incremented (+1), an internal reset takes effect.

RET

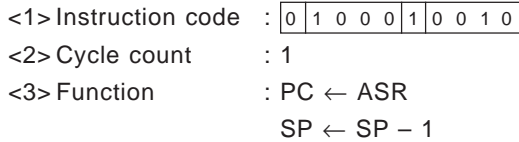

Restores the value saved in the address stack register to the program counter. Then, decrements (-1) the stack pointer. If a borrow is generated when the stack pointer value is decremented (-1), an internal reset takes effect.

9.9 Timer Operation Instructions

MOV A, T0

MOV A, T1

- <1> Instruction code :

1	1	1	1	0/1	1	1	1	1	1
---	---	---	---	-----	---	---	---	---	---
- <2> Cycle count : 1
- <3> Function : $(A) \leftarrow (T_n) \quad n = 0, 1$
CY ← 0

The timer T_n contents are transferred to the accumulator. T1 corresponds to (t₉, t₈, t₇, t₆); T0 corresponds to (t₅, t₄, t₃, t₂).

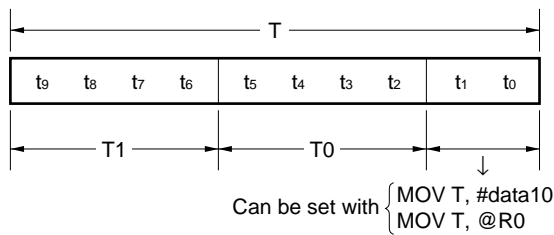

MOV T0, A

MOV T1, A

- <1> Instruction code :

0	0	1	0/1	1	1	1	1	1	1
---	---	---	-----	---	---	---	---	---	---
- <2> Cycle count : 1
- <3> Function : $(T_n) \leftarrow (A) \quad n = 0, 1$

The accumulator contents are transferred to the timer register T_n. T1 corresponds to (t₉, t₈, t₇, t₆); T0 corresponds to (t₅, t₄, t₃, t₂). After executing this instruction, if data is transferred to T1, t₁ becomes 0; if data is transferred to T0, t₀ becomes 0.

MOV T, #data10

- <1> Instruction code :

0	0	1	1	0	1	1	1	1	1
---	---	---	---	---	---	---	---	---	---

t ₁	t ₉	t ₈	t ₇	t ₆	t ₅	t ₄	t ₃	t ₂
----------------	----------------	----------------	----------------	----------------	----------------	----------------	----------------	----------------
- <2> Cycle count : 1
- <3> Function : $(T) \leftarrow \text{data10}$

The immediate data is transferred to the timer register T (t₉-t₀).

Remark The timer time is set with $(\text{set value} + 1) \times 8/f_x$ (or $16/f_x$).

MOV T, @R0

- <1> Instruction code :

0	0	1	1	1	1	1	1	1
---	---	---	---	---	---	---	---	---
- <2> Cycle count : 1
- <3> Function : $(T) \leftarrow ((P13), (R0))$

Transfers the program memory contents to the timer register T (t_9 to t_0) specified with the control register P13 and the register pair R_{10} - R_{00} .

The program memory, which consists of 10 bits, is placed in the following state after the transfer to the register.

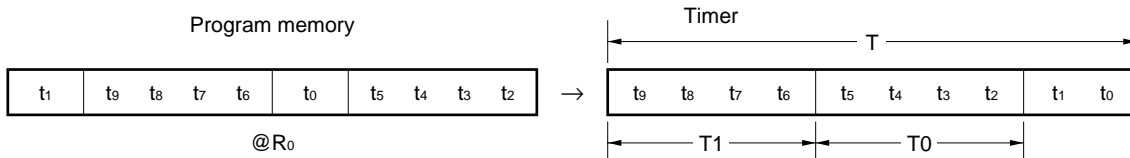

The high-order 2 bits of the program memory address are specified with the control register (P13).

Caution When setting a timer value in the program memory, ensure to use the DT directive.

9.10 Others

HALT #data4

- <1> Instruction code :

0	0	0	1	0	1	0	0	0	1
---	---	---	---	---	---	---	---	---	---

0	0	0	0	0	0	d_3	d_2	d_1	d_0
---	---	---	---	---	---	-------	-------	-------	-------
- <2> Cycle count : 1
- <3> Function : Standby mode

Places the CPU in standby mode.

The condition for having the standby mode (HALT/STOP mode) canceled is specified with the immediate data.

STTS R0n

- <1> Instruction code :

0	0	0	1	1	0	R_3	R_2	R_1	R_0
---	---	---	---	---	---	-------	-------	-------	-------
- <2> Cycle count : 1
- <3> Function : if statuses match $F \leftarrow 1$
 else $F \leftarrow 0$ $n = 0$ to F

Compares the S_0 , S_1 , $K_{I/O}$, K_I , and TIMER statuses with the register R_{0n} contents. If at least one of the statuses coincides with the bits that have been set, the status flag F is set (to 1).

If none of them coincide, the status flag F is cleared (to 0).

STTS #data4

<1> Instruction code :

0	0	0	1	1	0	0	0	1
---	---	---	---	---	---	---	---	---

 :

0	0	0	0	0	d ₃	d ₂	d ₁	d ₀
---	---	---	---	---	----------------	----------------	----------------	----------------

<2> Cycle count : 1

<3> Function : if statuses match F ← 1
 else F ← 0

Compares the S₀, S₁, K_{VO}, K_I, and TIMER statuses with the immediate data contents. If at least one of the statuses coincides with the bits that have been set, the status flag F is set (to 1).

If none of them coincide, the status flag F is cleared (to 0).

SCAF (Set Carry If Acc = FH)

<1> Instruction code :

1	1	0	1	0	1	0	0	1	1
---	---	---	---	---	---	---	---	---	---

<2> Cycle count : 1

<3> Function : if A = 0FH CY ← 1
 else CY ← 0

Sets the carry flag CY (to 1) if the accumulator contents are FH.

The accumulator values after executing the SCAF instruction are as follows:

Accumulator Value		Carry Flag
Before execution	After execution	
xxx0	0000	0 (clear)
xx01	0001	0 (clear)
x011	0011	0 (clear)
0111	0111	0 (clear)
1111	1111	1 (set)

Remark x: don't care

NOP

<1> Instruction code :

0	0	0	0	0	0	0	0	0	0
---	---	---	---	---	---	---	---	---	---

<2> Cycle count : 1

<3> Function : PC ← PC + 1

No operation

10. ASSEMBLER RESERVED WORDS

10.1 Mask Option Directives

When creating the μPD6133 program, it is necessary to use a mask option directive in the assembler's source program to specify a mask option.

10.1.1 OPTION and ENDOP directives

From the OPTION directive on to the ENDOP directive are called the mask option definition block. The format of the mask option definition block is as follows:

Format

<u>Symbol field</u> [Label:]	<u>Mnemonic field</u> OPTION : : ENDOP	<u>Operand field</u>	<u>Comment field</u> [: Comment]
---------------------------------	--	----------------------	-------------------------------------

10.1.2 Mask option definition directives

The directives that can be used in the mask option definition block are listed in Table 10-1. An example of the mask option definition is shown below.

Example

<u>Symbol field</u>	<u>Mnemonic field</u> OPTION USEPOC ENDOP	<u>Operand field</u>	<u>Comment field</u> ; POC circuit incorporated
---------------------	--	----------------------	--

Table 10-1. List of Mask Option Definition Directives

Name	Mask Option Definition Directive	PRO File	
		Address value	Data value
POC	USEPOC (POC circuit incorporated)	2044H	01
	NOUSEPOC (Without POC circuit)		00

11. ELECTRICAL SPECIFICATIONS

Absolute Maximum Ratings (T_A = +25 °C)

Parameter	Symbol	Test Conditions		Rating	Unit
Power supply voltage	V _{DD}			-0.3 to +5.0	V
Input voltage	V _I	K _{I/O} , K _I , S ₀ , S ₁ , $\overline{\text{RESET}}$		-0.3 to V _{DD} + 0.3	V
Output voltage	V _O			-0.3 to V _{DD} + 0.3	V
High-level output current	I _{OH} ^{Note}	REM	Peak value	-30	mA
			rms	-20	mA
		$\overline{\text{LED}}$	Peak value	-7.5	mA
			rms	-5	mA
		One K _{I/O} pin	Peak value	-13.5	mA
			rms	-9	mA
		Total of $\overline{\text{LED}}$ and K _{I/O} pins	Peak value	-18	mA
			rms	-12	mA
Low-level output current	I _{OL} ^{Note}	REM	Peak value	7.5	mA
			rms	5	mA
		$\overline{\text{LED}}$	Peak value	7.5	mA
			rms	5	mA
Operating ambient temperature	T _A			-40 to +85	°C
Storage temperature	T _{stg}			-65 to +150	°C

Note Work out the rms with: [rms] = [Peak value] × √Duty.

Caution Product quality may suffer if the absolute rating is exceeded for any parameter, even momentarily. In other words, an absolute maximum rating is a value at which the possibility of physical damage to the product cannot be ruled out. Care must therefore be taken to ensure that these ratings are not exceeded during use of the product.

Recommended Power Supply Voltage Range (T_A = -40 to +85 °C)

Parameter	Symbol	Test Conditions	MIN.	TYP.	MAX.	Unit
Power supply voltage	V _{DD}	f _x = 300 to 500 kHz	1.8	3.0	3.6	V
		f _x = 500 kHz to 1 MHz	2.2	3.0	3.6	V
		When using the POC circuit (mask option) T _A = -20 to +70 °C f _x = 300 to 500 kHz	2.2	3.0	3.6	V

DC Characteristics (T_A = -40 to +85 °C, V_{DD} = 1.8 to 3.6 V)

Parameter	Symbol	Test Conditions		MIN.	TYP.	MAX.	Unit
High-level input voltage	V _{IH1}	RESET		0.8 V _{DD}		V _{DD}	V
	V _{IH2}	K/I/O		0.65 V _{DD}		V _{DD}	V
	V _{IH3}	K ₁ , S ₀ , S ₁		0.65 V _{DD}		V _{DD}	V
Low-level input voltage	V _{IL1}	RESET		0		0.2 V _{DD}	V
	V _{IL2}	K/I/O		0		0.3 V _{DD}	V
	V _{IL3}	K ₁ , S ₀ , S ₁		0		0.15 V _{DD}	V
High-level input leakage current	I _{LIH1}	K ₁ V _I = V _{DD} , pull-down resistor not incorporated				3	μA
	I _{LIH2}	S ₀ , S ₁ V _I = V _{DD} , pull-down resistor not incorporated				3	μA
Low-level input leakage current	I _{LIL1}	K ₁ V _I = 0 V				-3	μA
	I _{LIL2}	K/I/O V _I = 0 V				-3	μA
	I _{LIL3}	S ₀ , S ₁ V _I = 0 V				-3	μA
High-level output voltage	V _{OH1}	REM, LED, K/I/O	I _{OH} = -0.3 mA	0.8 V _{DD}			V
Low-level output voltage	V _{OL1}	REM, LED	I _{OL} = 0.3 mA			0.3	V
	V _{OL2}	K/I/O	I _{OL} = 15 μA			0.4	V
High-level output current	I _{OH1}	REM	V _{DD} = 3.0 V, V _{OH} = 1.0 V	-5	-9		mA
	I _{OH2}	K/I/O	V _{DD} = 3.0 V, V _{OH} = 2.2 V	-2.5	-5		mA
Low-level output current	I _{OL1}	K/I/O	V _{DD} = 3.0 V, V _{OL} = 0.4 V	30	70		μA
			V _{DD} = 3.0 V, V _{OL} = 2.2 V	100	220		μA
Built-in pull-up resistor	R ₁	RESET		25	50	100	kΩ
Built-in pull-down resistor	R ₂	RESET		2.5	5	15	kΩ
	R ₃	K ₁ , S ₀ , S ₁		75	150	300	kΩ
	R ₄	K/I/O		130	250	500	kΩ
Data hold power supply voltage	V _{DDDR}	In STOP mode		0.9		3.6	V
Supply current ^{†Note}	I _{DD1}	OPERATING mode	f _X = 1.0 MHz, V _{DD} = 3 V ± 10 %		0.4	0.8	mA
			f _X = 455 kHz, V _{DD} = 3 V ± 10 %		0.35	0.7	mA
	I _{DD2}	HALT mode	f _X = 1.0 MHz, V _{DD} = 3 V ± 10 %		0.35	0.7	mA
			f _X = 455 kHz, V _{DD} = 3 V ± 10 %		0.3	0.6	mA
	I _{DD3}	STOP mode	V _{DD} = 3 V ± 10 %		1.0	8.0	μA
			V _{DD} = 3 V ± 10 %, T _A = 25 °C		0.1	1.0	μA

Note The POC circuit current and the current flowing in the built-in pull-up resistor are not included.

AC Characteristics (T_A = -40 to +85 °C, V_{DD} = 1.8 to 3.6 V)

Parameter	Symbol	Test Conditions	MIN.	TYP.	MAX.	Unit
Command execution time	t _{CY}	V _{DD} = 2.2 to 3.6 V	7.9		27	μs
			15.9		27	μs
K _i , S ₀ , S ₁ high-level width	t _H	When releasing Standby mode	10			μs
			in HALT mode	10		μs
			in STOP mode	Note		μs
RESET low-level width	t _{RSL}		10			μs

Note 10 + 36/f_x + oscillation growth time

Remark t_{CY} = 8/f_x (f_x: System clock oscillator frequency)

POC Circuit (mask option^{Note 1}) (T_A = -20 to +70 °C)

Parameter	Symbol	Test Conditions	MIN.	TYP.	MAX.	Unit
POC-detected voltage ^{Note 2}	V _{POC}		0.9	1.6	2.2	V
POC circuit current	I _{POC}			0.9	1.0	μA

- ★ **Notes**
 1. Operates effectively under the conditions of f_x = 300 to 500 kHz.
 2. Refers to the voltage with which the POC circuit cancels an internal reset. If V_{POC} < V_{DD}, the internal reset is released.
From the time of V_{POC} ≥ V_{DD} until the internal reset takes effect, lag of up to 1 ms occurs. When the period of V_{POC} ≥ V_{DD} lasts less than 1 ms, the internal reset may not take effect.

System Clock Oscillator Characteristics (T_A = -40 to +85 °C, V_{DD} = 1.8 to 3.6 V)

Parameter	Symbol	Test Conditions	MIN.	TYP.	MAX.	Unit
Oscillator frequency (ceramic resonator)	f _x		300	455	500	kHz
		V _{DD} = 2.2 to 3.6 V	300	455	1000	kHz

Recommended Ceramic Resonator (T_A = -40 to +85 °C)

Manufacturer (Order Disregarded)	Part Number	Recommended Constant			Power Supply Voltage [V] ^{Note}		Remark
		C1 [pF]	C1 [pF]	Rd [kΩ]	MIN.	MAX.	
Murata Mfg. Co., Ltd	CSB455E	150	150	0	1.8	3.6	
	CSB600P	150	150	0	2.2	3.6	
	CSB910J	100	100	0	2.2	3.6	
Kyocera Corp.	KBR-455BK	220	220	0	1.8	3.6	
	KBR-455BY	220	220	0	1.8	3.6	
	KBR-1000F	100	100	0	2.2	3.6	
	KBR-1000Y	100	100	0	2.2	3.6	
TDK Corp.	FCR400K3	220	220	0	1.8	3.6	
	FCR455K3	220	220	0	1.8	3.6	
	FCR500K3	220	220	0	1.8	3.6	
Matsushita Electronics Components Co., Ltd.	EFOA440K06B	470	470	0	1.8	3.6	
	EFOA455K06B	470	470	0	1.8	3.6	
	EFOA480K06B	470	470	0	1.8	3.6	

Note When a POC circuit (mask option) is not incorporated

An external circuit example

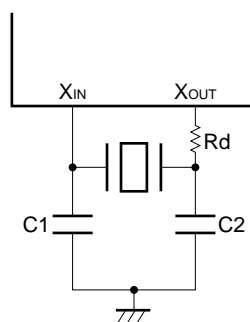

12. CHARACTERISTIC CURVE (REFERENCE VALUES) (common to μ PD6133 and 6134)

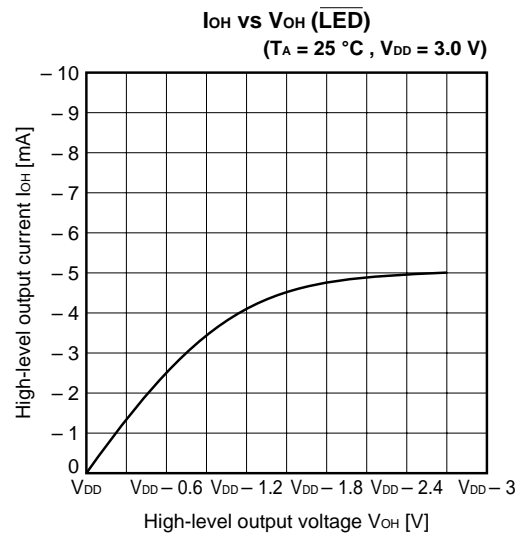
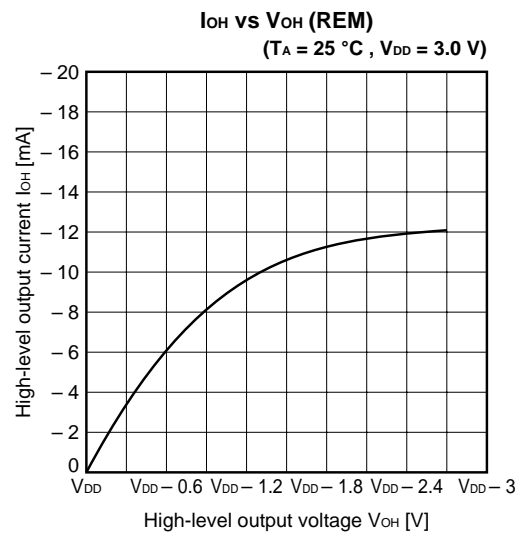
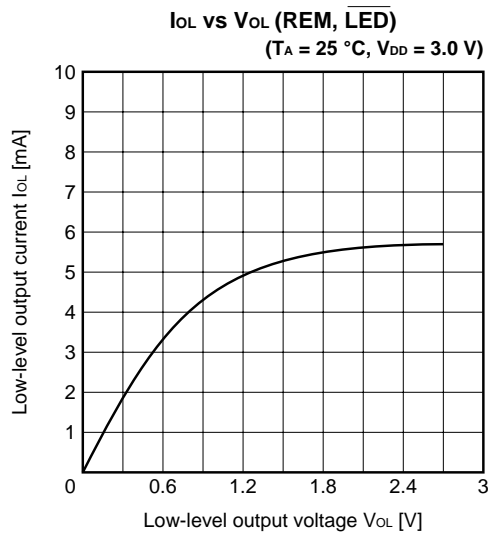
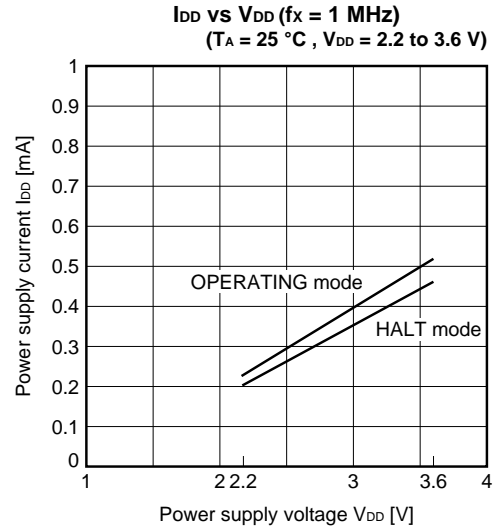
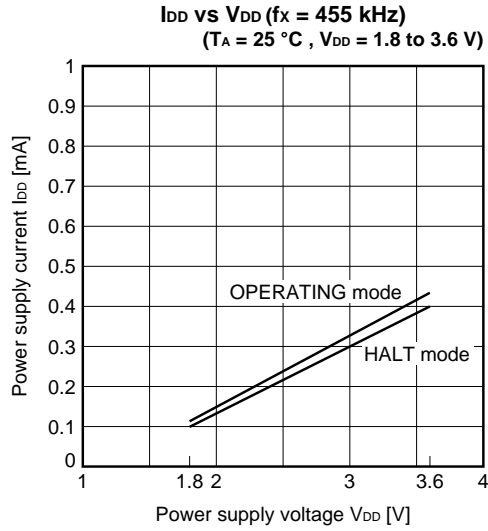

I_{OL} vs V_{OL} ($K_{I/O}$)
 ($T_A = 25\text{ }^\circ\text{C}$, $V_{DD} = 3.0\text{ V}$)

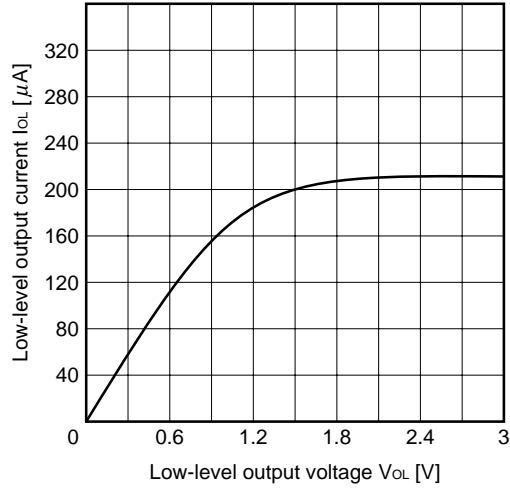

I_{OH} vs V_{OH} ($K_{I/O}$)
 ($T_A = 25\text{ }^\circ\text{C}$, $V_{DD} = 3.0\text{ V}$)

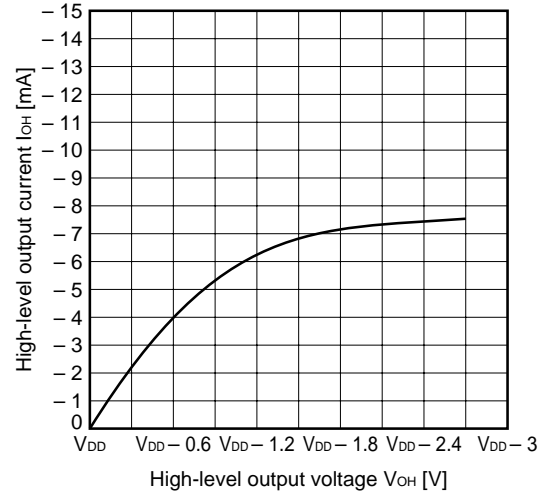

13. APPLIED CIRCUIT EXAMPLE

Example of Application to System

- Remote-control transmitter (40 keys; mode selection switch accommodated)

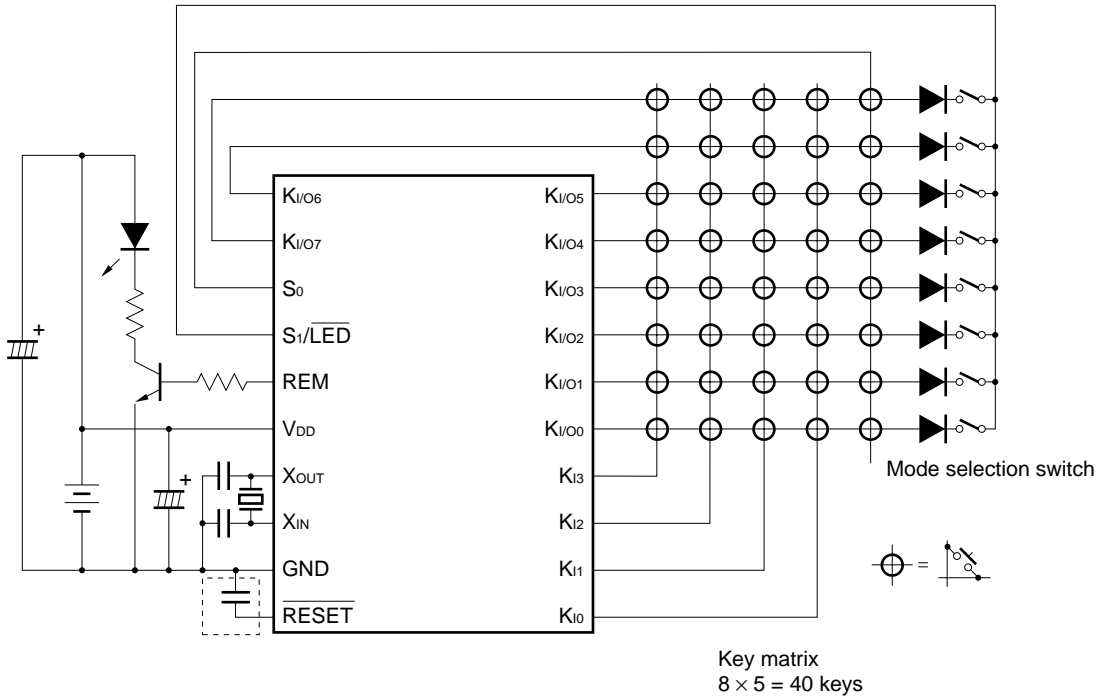

- Remote-control transmitter (48 keys accommodated)

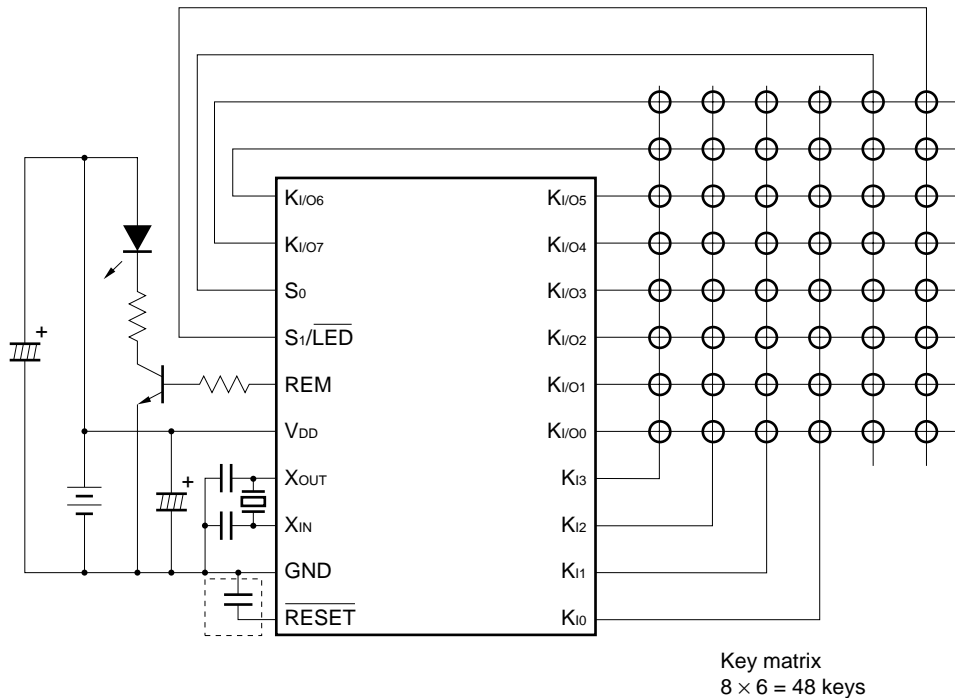

Remark When the POC circuit of the mask option is used effectively, it is not necessary to connect the capacitor enclosed in the dotted lines.

14. PACKAGE DRAWINGS

20 PIN PLASTIC SOP (300 mil)

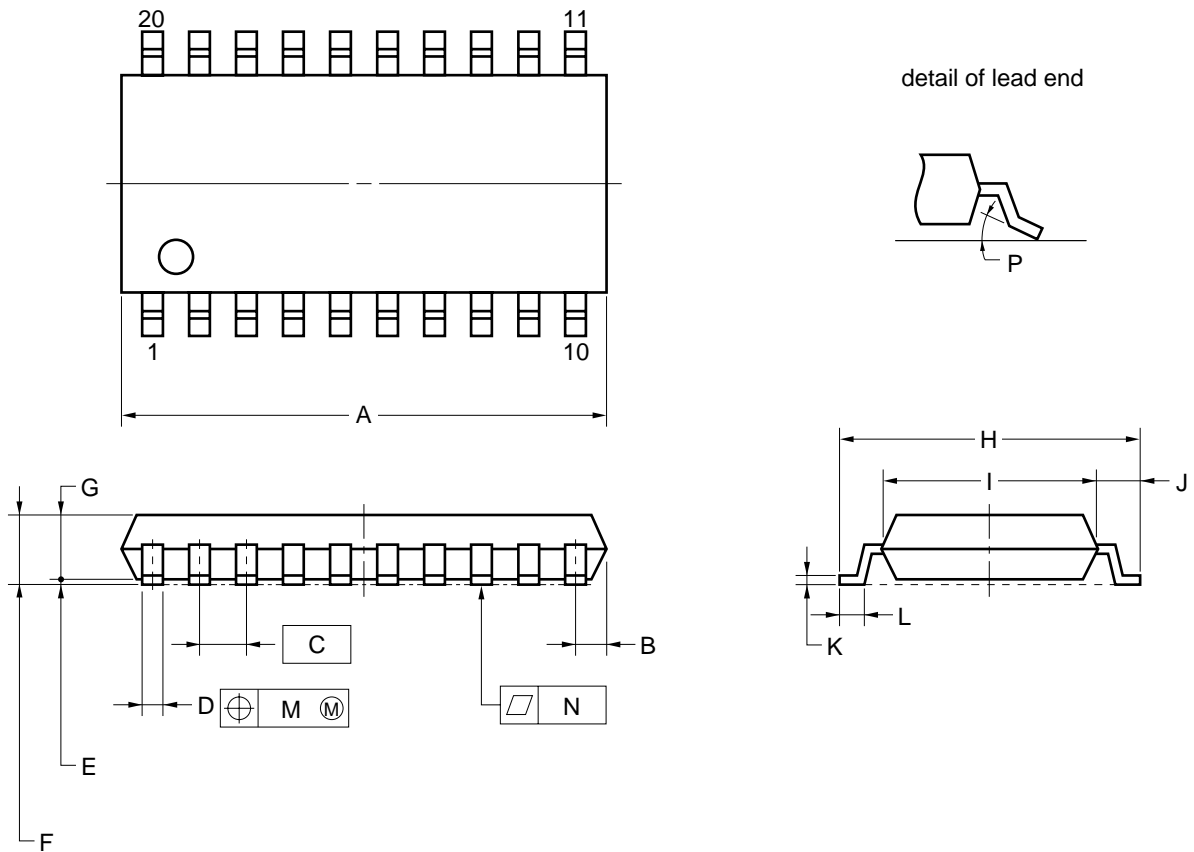

NOTE

Each lead centerline is located within 0.12 mm (0.005 inch) of its true position (T.P.) at maximum material condition.

ITEM	MILLIMETERS	INCHES
A	12.7±0.3	0.500±0.012
B	0.78 MAX.	0.031 MAX.
C	1.27 (T.P.)	0.050 (T.P.)
D	0.42 ^{+0.08} _{-0.07}	0.017 ^{+0.003} _{-0.004}
E	0.1±0.1	0.004±0.004
F	1.8 MAX.	0.071 MAX.
G	1.55±0.05	0.061±0.002
H	7.7±0.3	0.303±0.012
I	5.6±0.2	0.220 ^{+0.009} _{-0.008}
J	1.1	0.043
K	0.22 ^{+0.08} _{-0.07}	0.009 ^{+0.003} _{-0.004}
L	0.6±0.2	0.024 ^{+0.008} _{-0.009}
M	0.12	0.005
N	0.10	0.004
P	3°+7° -3°	3°+7° -3°

P20GM-50-300B, C-5

Remark The dimensions and materials of the ES model are the same as those of mass production model.

★ 20 PIN PLASTIC SSOP (300 mil)

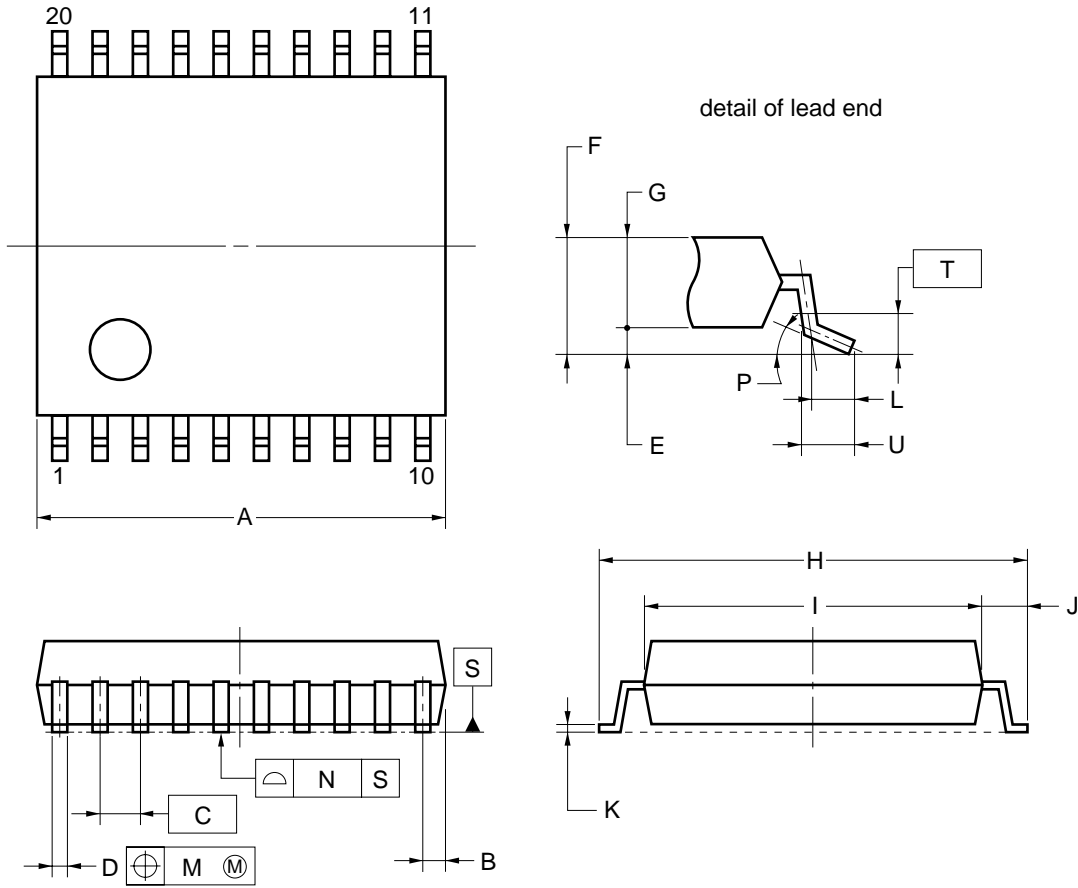

NOTE
 Each lead centerline is located within 0.12 mm of its true position (T.P.) at maximum material condition.

ITEM	MILLIMETERS
A	6.65±0.15
B	0.475 MAX.
C	0.65 (T.P.)
D	0.24 ^{+0.08} _{-0.07}
E	0.1±0.05
F	1.3±0.1
G	1.2
H	8.1±0.2
I	6.1±0.2
J	1.0±0.2
K	0.17±0.03
L	0.5
M	0.13
N	0.10
P	3° ^{+5°} _{-3°}
T	0.25
U	0.6±0.15

S20MC-65-5A4-1

Remark The dimensions and materials of the ES model are the same as those of mass production model.

15. RECOMMENDED SOLDERING CONDITIONS

Carry out the soldered packaging of this product under the following recommended conditions.

For details of the soldering conditions, refer to information material **Semiconductor Device Mounting Technology Manual (C10535E)**.

For soldering methods and conditions other than the recommended conditions, please consult one of our NEC sales representatives.

Table 15-1. Soldering Conditions for Surface-Mount Type

(1) μPD6133GS-xxx: 20-pin plastic SOP (300 mil)

μPD6134GS-xxx: 20-pin plastic SOP (300 mil)

Soldering Method	Soldering Condition	Recommended Condition Symbol
Infrared reflow	Package peak temperature: 235 °C; time: 30 secs. max. (210 °C min.); count: twice max.	IR35-00-2
VPS	Package peak temperature: 215 °C; time: 40 secs. max. (200 °C min.); count: twice max.	VP15-00-2
Wave soldering	Solder bath temperature: 260 °C max.; time: 10 secs. max.; count: once; Preliminary heat temperature: 120 °C max. (Package surface temperature)	WS60-00-1
Partial heating	Pin temperature: 300 °C or less ; time: 3 secs. max. (for each side of the device)	—

Caution Using more than one soldering method should be avoided (except in the case of partial heating).

★ (2) μPD6134MC-xxx-5A4: 20-pin plastic SSOP (300 mil)

Soldering Method	Soldering Condition	Recommended Condition Symbol
Infrared reflow	Package peak temperature: 235 °C; time: 30 secs. max. (210 °C min.); count: three times max.	IR35-00-3
VPS	Package peak temperature: 215 °C; time: 40 secs. max. (200 °C min.); count: three times max.	VP15-00-3
Wave soldering	Solder bath temperature: 260 °C max.; time: 10 secs. max.; count: once; Preliminary heat temperature: 120 °C max. (Package surface temperature)	WS60-00-1
Partial heating	Pin temperature: 300 °C or less ; time: 3 secs. max. (for each side of the device)	—

Caution Using more than one soldering method should be avoided (except in the case of partial heating).

APPENDIX A. DEVELOPMENT TOOLS

An emulator is provided for the μPD6133.

Hardware

- **Emulator (EB-6133^{Note})**

It is used to emulate the μPD6133.

Note This is a product of Naito Densai Machida Mfg. Co., Ltd. For details, consult Naito Densai Machida Mfg. Co., Ltd. (044-822-3813).

Software

- **Assembler (AS6133)**

- This is a development tool for remote control transmitter software.

Part Number List of AS6133

Host Machine	OS	Supply Medium	Part Number
PC-9800 series (CPU: 80386 or more)	MS-DOS™ (Ver. 5.0 to Ver. 6.2)	3.5-inch 2HD	μS5A13AS6133
IBM PC/AT™ compatible	MS-DOS (Ver. 6.0 to Ver. 6.22)	3.5-inch 2HC	μS7B13AS6133
	PC DOS™ (Ver. 6.1 to Ver. 6.3)		

Caution Although Ver.5.0 or later has a task swap function, this function cannot be used with this software.

APPENDIX B. FUNCTIONAL COMPARISON BETWEEN μPD6133 SUBSERIES AND OTHER SUBSERIES

Item		μPD6133	μPD6134	μPD6600A	μPD6124A
ROM capacity		512 × 10 bits	1002 × 10 bits	512 × 10 bits	1002 × 10 bits
RAM capacity		32 × 4 bits		32 × 5 bits	
Stack		1 level (multiplexed with RF of RAM)		3 levels (multiplexed with RAM)	
Key matrix		8 × 6 = 48 keys		8 × 4 = 32 keys	
S ₀ (S-IN) input		Read by P ₀₁ register (with function to release standby mode)		Read by left shift instruction	
S ₁ /LED (S-OUT)		I/O (with function to release standby mode)		Output	
Clock frequency		Ceramic oscillation • f _x = 300 kHz to 1 MHz • f _x = 300 to 500 kHz (with POC circuit)		Ceramic oscillation • f _x = 400 to 500 kHz	
Timer	Clock	f _x /8, f _x /16		f _x /8	
	Count start	Writing count value		Writing count value and P1 register value	
Carrier	Frequency	• f _x , f _x /8, f _x /12 (timer clock: f _x /8) • f _x /2, f _x /16, f _x /24 (timer clock: f _x /16) • No carrier		• f _x /8, f _x /12	
	Output start	Synchronized with timer		Not synchronized with timer	
Instruction execution time		8 μs (f _x = 1 MHz)		16 μs (f _x = 500 kHz)	
Relative branch instruction		None		Provided	
Left shift instruction		None		Provided	
"MOV Rn, @R0" instruction		n = 1 to F		n = 0 to F	
Standby mode (HALT instruction)		HALT mode for timer only. STOP mode for only releasing K _I (K _{I/O} high-level output or K _{I/O0} high-level output)		HALT/STOP mode set by P1 register value	
Relation between HALT instruction execution and status flag (F)		HALT instruction not executed when F = 1		HALT instruction executed regardless of status of F	
Reset function by charging/discharging capacitor		None		Provided	
POC circuit		Mask option Low level output to RESET pin on detection		Provided (low-voltage detection circuit) Low level output to S-OUT pin on detection	
Mask option		POC circuit only (Circuits other than POC circuit are set by software.)		• Pull-down resistor • Variable duty • Hang-up detection	
Supply voltage		V _{DD} = 1.8 to 3.6 V		• V _{DD} = 2.2 to 3.6 V	• V _{DD} = 2.2 to 5.5 V
Operating temperature		• T _A = -40 to +85 °C • T _A = -20 to +70 °C (with POC circuit)		• T _A = -20 to +70 °C	
★	Package	• 20-pin plastic SOP	• 20-pin plastic SOP • 20-pin plastic SSOP	• 20-pin plastic SOC • 20-pin plastic shrink DIP	
One-time PROM product		μPD61P34B		μPD61P24	

APPENDIX C. EXAMPLE OF REMOTE-CONTROL TRANSMISSION FORMAT
 (in the case of NEC transmission format in command one-shot transmission mode)

Caution When using the NEC transmission format, please apply for a custom code at NEC.

(1) REM output waveform (From <2> on, the output is made only when the key is kept pressed.)

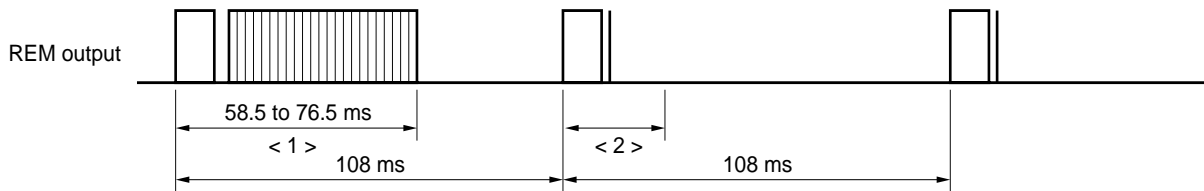

Remark If the key is repeatedly pressed, the power consumption of the infrared light-emitting diode (LED) can be reduced by sending the reader code and the stop bit from the second time.

(2) Enlarged waveform of <1>

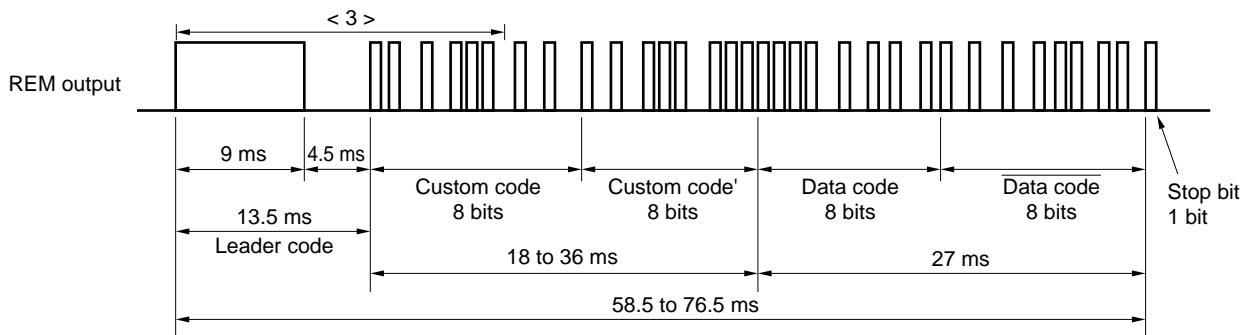

(3) Enlarged waveform of <3>

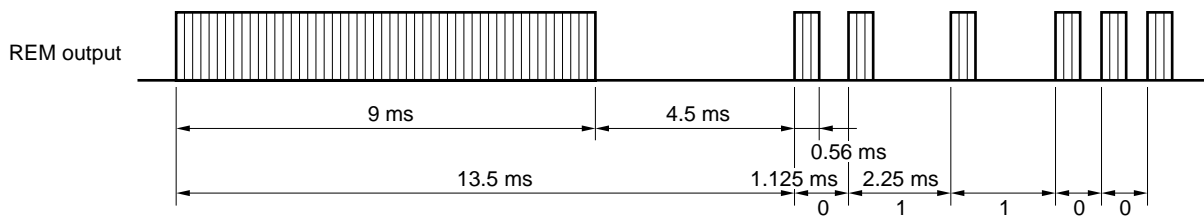

(4) Enlarged waveform of <2>

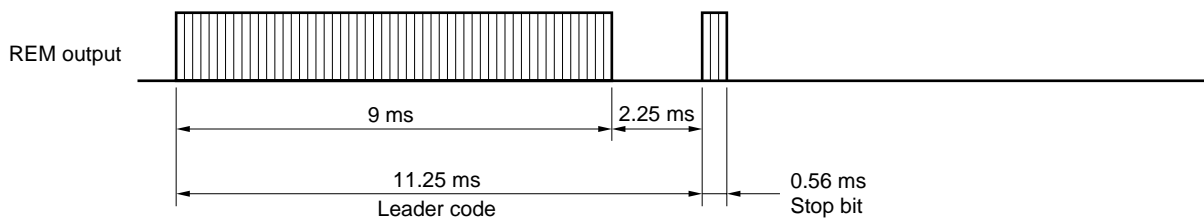

(5) Carrier waveform (Enlarged waveform of each code's high period)

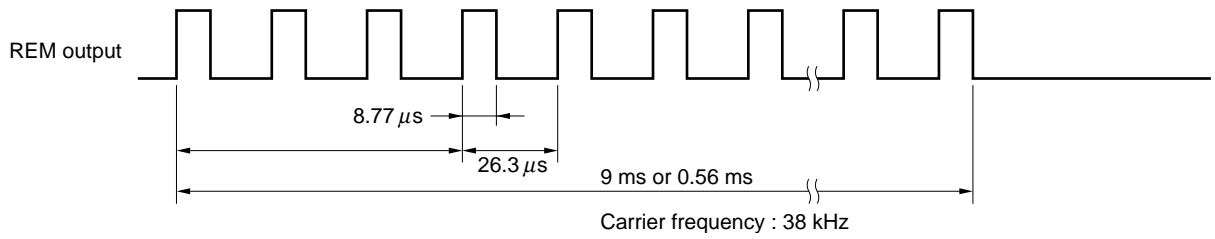

(6) Bit array of each code

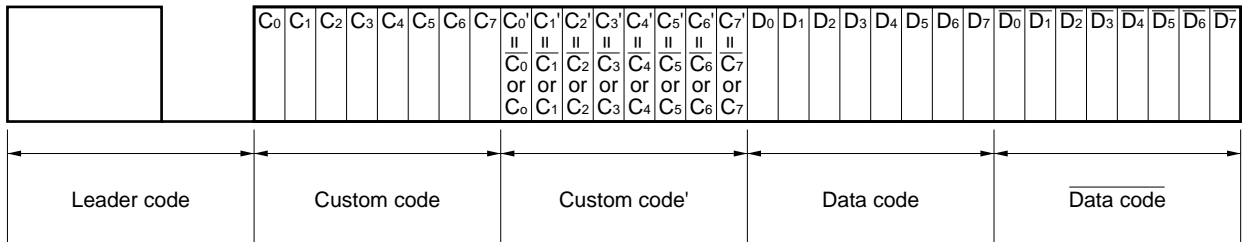

Caution To prevent malfunction with other systems when receiving data in the NEC transmission format, not only fully decode (make sure to check Data Code as well) the total 32 bits of the 16-bit custom codes (Custom Code, Custom Code') and the 16-bit data codes (Data Code, Data Code) but also check to make sure that no signals are present.

NOTES FOR CMOS DEVICES**① PRECAUTION AGAINST ESD FOR SEMICONDUCTORS**

Note:

Strong electric field, when exposed to a MOS device, can cause destruction of the gate oxide and ultimately degrade the device operation. Steps must be taken to stop generation of static electricity as much as possible, and quickly dissipate it once, when it has occurred. Environmental control must be adequate. When it is dry, humidifier should be used. It is recommended to avoid using insulators that easily build static electricity. Semiconductor devices must be stored and transported in an anti-static container, static shielding bag or conductive material. All test and measurement tools including work bench and floor should be grounded. The operator should be grounded using wrist strap. Semiconductor devices must not be touched with bare hands. Similar precautions need to be taken for PW boards with semiconductor devices on it.

② HANDLING OF UNUSED INPUT PINS FOR CMOS

Note:

No connection for CMOS device inputs can be cause of malfunction. If no connection is provided to the input pins, it is possible that an internal input level may be generated due to noise, etc., hence causing malfunction. CMOS devices behave differently than Bipolar or NMOS devices. Input levels of CMOS devices must be fixed high or low by using a pull-up or pull-down circuitry. Each unused pin should be connected to V_{DD} or GND with a resistor, if it is considered to have a possibility of being an output pin. All handling related to the unused pins must be judged device by device and related specifications governing the devices.

③ STATUS BEFORE INITIALIZATION OF MOS DEVICES

Note:

Power-on does not necessarily define initial status of MOS device. Production process of MOS does not define the initial operation status of the device. Immediately after the power source is turned ON, the devices with reset function have not yet been initialized. Hence, power-on does not guarantee out-pin levels, I/O settings or contents of registers. Device is not initialized until the reset signal is received. Reset operation must be executed immediately after power-on for devices having reset function.

Regional Information

Some information contained in this document may vary from country to country. Before using any NEC product in your application, please contact the NEC office in your country to obtain a list of authorized representatives and distributors. They will verify:

- Device availability
- Ordering information
- Product release schedule
- Availability of related technical literature
- Development environment specifications (for example, specifications for third-party tools and components, host computers, power plugs, AC supply voltages, and so forth)
- Network requirements

In addition, trademarks, registered trademarks, export restrictions, and other legal issues may also vary from country to country.

NEC Electronics Inc. (U.S.)

Santa Clara, California
Tel: 408-588-6000
800-366-9782
Fax: 408-588-6130
800-729-9288

NEC Electronics (Germany) GmbH

Duesseldorf, Germany
Tel: 0211-65 03 02
Fax: 0211-65 03 490

NEC Electronics (UK) Ltd.

Milton Keynes, UK
Tel: 01908-691-133
Fax: 01908-670-290

NEC Electronics Italiana s.r.l.

Milano, Italy
Tel: 02-66 75 41
Fax: 02-66 75 42 99

NEC Electronics (Germany) GmbH

Benelux Office
Eindhoven, The Netherlands
Tel: 040-2445845
Fax: 040-2444580

NEC Electronics (France) S.A.

Velizy-Villacoublay, France
Tel: 01-30-67 58 00
Fax: 01-30-67 58 99

NEC Electronics (France) S.A.

Spain Office
Madrid, Spain
Tel: 91-504-2787
Fax: 91-504-2860

NEC Electronics (Germany) GmbH

Scandinavia Office
Taebly, Sweden
Tel: 08-63 80 820
Fax: 08-63 80 388

NEC Electronics Hong Kong Ltd.

Hong Kong
Tel: 2886-9318
Fax: 2886-9022/9044

NEC Electronics Hong Kong Ltd.

Seoul Branch
Seoul, Korea
Tel: 02-528-0303
Fax: 02-528-4411

NEC Electronics Singapore Pte. Ltd.

United Square, Singapore 1130
Tel: 65-253-8311
Fax: 65-250-3583

NEC Electronics Taiwan Ltd.

Taipei, Taiwan
Tel: 02-2719-2377
Fax: 02-2719-5951

NEC do Brasil S.A.

Electron Devices Division
Rodovia Presidente Dutra, Km 214
07210-902-Guarulhos-SP Brasil
Tel: 55-11-6465-6810
Fax: 55-11-6465-6829

J99.1

MS-DOS is either a registered trademark or a trademark of Microsoft Corporation in the United States and/or other countries.

PC/AT and PC DOS are trademarks of IBM Corp.

The export of this product from Japan is regulated by the Japanese government. To export this product may be prohibited without governmental license, the need for which must be judged by the customer. The export or re-export of this product from a country other than Japan may also be prohibited without a license from that country. Please call an NEC sales representative.

- **The information in this document is subject to change without notice. Before using this document, please confirm that this is the latest version.**
 - No part of this document may be copied or reproduced in any form or by any means without the prior written consent of NEC Corporation. NEC Corporation assumes no responsibility for any errors which may appear in this document.
 - NEC Corporation does not assume any liability for infringement of patents, copyrights or other intellectual property rights of third parties by or arising from use of a device described herein or any other liability arising from use of such device. No license, either express, implied or otherwise, is granted under any patents, copyrights or other intellectual property rights of NEC Corporation or others.
 - Descriptions of circuits, software, and other related information in this document are provided for illustrative purposes in semiconductor product operation and application examples. The incorporation of these circuits, software, and information in the design of the customer's equipment shall be done under the full responsibility of the customer. NEC Corporation assumes no responsibility for any losses incurred by the customer or third parties arising from the use of these circuits, software, and information.
 - While NEC Corporation has been making continuous effort to enhance the reliability of its semiconductor devices, the possibility of defects cannot be eliminated entirely. To minimize risks of damage or injury to persons or property arising from a defect in an NEC semiconductor device, customers must incorporate sufficient safety measures in its design, such as redundancy, fire-containment, and anti-failure features.
 - NEC devices are classified into the following three quality grades:
"Standard", "Special", and "Specific". The Specific quality grade applies only to devices developed based on a customer designated "quality assurance program" for a specific application. The recommended applications of a device depend on its quality grade, as indicated below. Customers must check the quality grade of each device before using it in a particular application.
 - Standard: Computers, office equipment, communications equipment, test and measurement equipment, audio and visual equipment, home electronic appliances, machine tools, personal electronic equipment and industrial robots
 - Special: Transportation equipment (automobiles, trains, ships, etc.), traffic control systems, anti-disaster systems, anti-crime systems, safety equipment and medical equipment (not specifically designed for life support)
 - Specific: Aircraft, aerospace equipment, submersible repeaters, nuclear reactor control systems, life support systems or medical equipment for life support, etc.
- The quality grade of NEC devices is "Standard" unless otherwise specified in NEC's Data Sheets or Data Books. If customers intend to use NEC devices for applications other than those specified for Standard quality grade, they should contact an NEC sales representative in advance.