

### FEATURES

- Current output
- Space saving package(SOP8 )
- Low power consumption
- Low total harmonic distortion
- Wide dynamic range(16-bit resolution)
- Fast setting time permits 2\*, 4\*, and 8\* oversampling(serial input) or double speed operation at 4\* oversampling
- Internal bias current ensures maximum dynamic range
- Wide operating temperature range of -40°C to 85°C
- Internal timing and control circuits
- Compatible with most of the Japanese input formats; time multiplexed, two's complement, TTL
- No zero crossing distortion
- Easy application :  
Operation range: 2.7V~5.5V  
Output and bias current are proportional to supply voltage

### APPLICATIONS

DVD Player, multimedia system.

### DESCRIPTION

The MS6610 is a 16-bit current-output Digital-to-Analog Converter(DAC). The MS6610 is fabricated in a CMOS process and features extremely low power dissipation, small package size and ease of application. The accuracy of the matched coarse current sources, combined with the unique symmetrical decoding method, preclude zero-crossing distortion and ensures high quality audio reproduction. These unique features, combined with its exceptional performance, make the MS6610 ideally suited for use in digital audio equipment. MS6610 is pin and function compatible with the Philips, TDA1545.

### PINNING

Symbol	Pin	Description
BCK	1	bit clock input
WS	2	word select input
DATA	3	data input
GND	4	ground
V <sub>DD</sub>	5	positive supply voltage
I <sub>OL</sub>	6	left channel output
I <sub>REF</sub>	7	reference current input
I <sub>OR</sub>	8	right channel output

**Pin configuration**

### BLOCK DIAGRAM

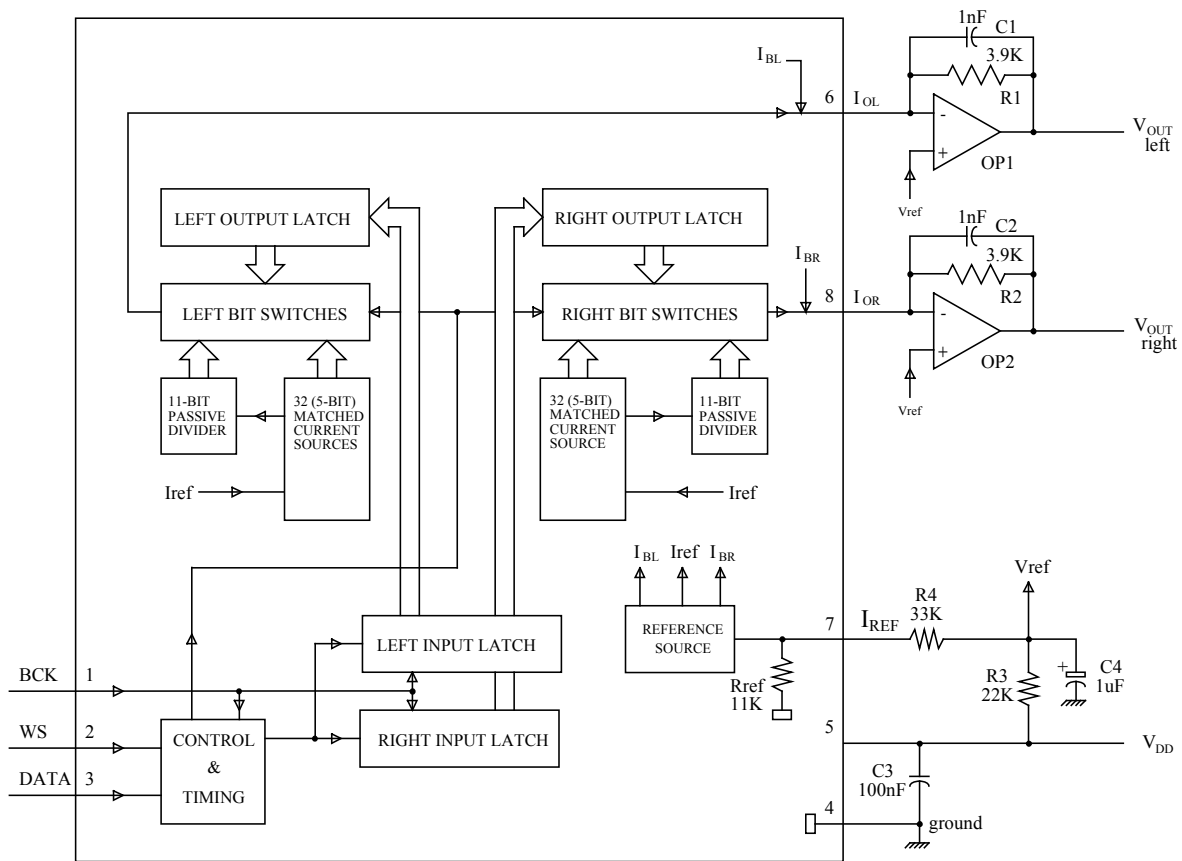

Fig.1 Block diagram.

### LIMITING VALUES

Symbol	Parameter	Min	Max	Unit
VDD	Positive Supply Voltage	-	6	V
Tsig	Storage Temperature Range	-55	+150	°C
TXTAL	Maximum Crystal Temperature	-	+150	°C
TAMB	Operating Ambient Temperature Range	-40	+85	°C
Ves	Electrostatic Handling	-2000	2000	V

### ELECTRICAL CHARACTERISTICS

(Ta=25°C, V<sub>DD</sub>=5V)

SYM	PARAMETER	CONDITIONS	MIN	TYP	MAX	UNIT
V <sub>DD</sub>	Positive Supply Voltage		2.7	5	5.5	V
I <sub>DD</sub>	Operating Current	at code 0000H	-	3	5	mA
PSSR	Power Ripple Rejection Ratio		-	30		dB

### DIGITAL INPUTS (WS, BCK, DATA)

SYM	PARAMETER	CONDITIONS	MIN	TYP	MAX	UNIT
f <sub>BCK</sub>	Input Clock Frequency				18.4	MHz
BR	Bit Rate Data Input (Pin 3)				18.4	Mbits/s
FWS	Word Select Input (Pin 2)				384	kHz
t <sub>r</sub>	Rise Time				12	ns
t <sub>f</sub>	Fall Time				12	ns
t <sub>Cr</sub>	Bit Clock Cycle Time		54			ns
t <sub>HB</sub>	Bit Clock High Time		15			ns
t <sub>LB</sub>	Bit Clock Low Time		15			ns
t <sub>SD</sub>	Data Set-up Time		12			ns
t <sub>HD</sub>	Data Hold Time to Bit Clock		2			ns
t <sub>HW</sub>	Word Select Hold Time		2			ns
t <sub>SW</sub>	Word Select Set-up Time		12			ns

### ANALOG INPUT (I<sub>ref</sub>)

SYM	PARAMETER	CONDITIONS	MIN	TYP	MAX	UNIT
R <sub>ref</sub>	Reference Resistor (Fig.1)		7.4	11.0	14.6	K

### ANALOG OUTPUT (I<sub>OL</sub>, I<sub>OR</sub>)

SYM	PARAMETER	CONDITIONS	MIN	TYP	MAX	UNIT
Res	Resolution				16	bits
V <sub>DCC</sub>	DC output Voltage Compliance		2.0		V <sub>DD</sub> -1	V
I <sub>FS</sub>	Full Scale Output Current	I <sub>FS</sub> = 0.2V <sub>DD</sub>	0.9	1.0	1.1	mA
T <sub>CFS</sub>	Full Scale Temperature Coefficient at Analog Outputs ; I <sub>OL</sub> , I <sub>OR</sub>			±400		10 <sup>-16</sup>
P <sub>tot</sub>	Total Power Dissipation	at code 0000H		15		mW
I <sub>bias</sub>	Bias Current (adjustable)		643	714	785	μA
THD	Total Harmonic Distortion	including noise at 0 dB		-85	-78	dB
THD	Total Harmonic Distortion	including noise at -60 dB		0.005	0.01	%
THD	Total Harmonic Distortion	including noise at -60 dB		-30	-24	dB
S/N	Signal-to-Noise Ratio	a-weighted at code 0000H		3	6	%
S/N	Signal-to-Noise Ratio	a-weighted at code 0000H		92		dB
CS	Channel Separation			95		dB

## TIMING AND DATA FORMAT

The MS6610 accepts input serial data formats of 16-bit word length. Left and right data words are time multiplexed. The MSB(bit 1) must always be First. The format of data input is shown in Figs. 2 and 3. With a LOW level on the word select input(WS) input data is placed in the right input register and with HIGH level on the WS input data is placed in the left register. The data in the input registers are simultaneously latched in the output registers which control the bit switches. Internal bias currents IBL and IBR are each added to the full scale output current IFS in order to achieve the maximum dynamic range at the outputs of OP1 and OP2(Fig. 1). The reference output voltage  $V_{ref}$ (Fig. 1) is  $2/3 V_{DD}$ . In this way the maximum dynamic range is achieved over the entire power supply range.

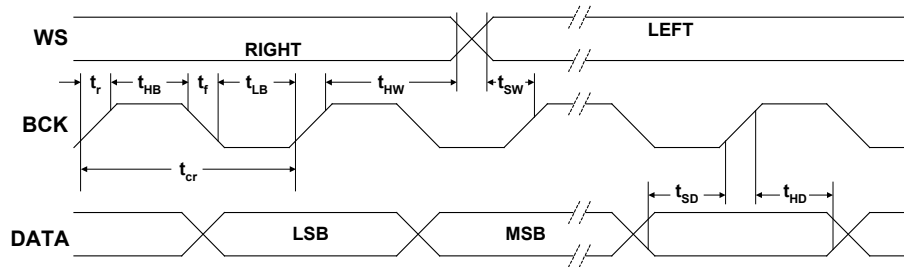

**Fig.2 Timing and input signals.**

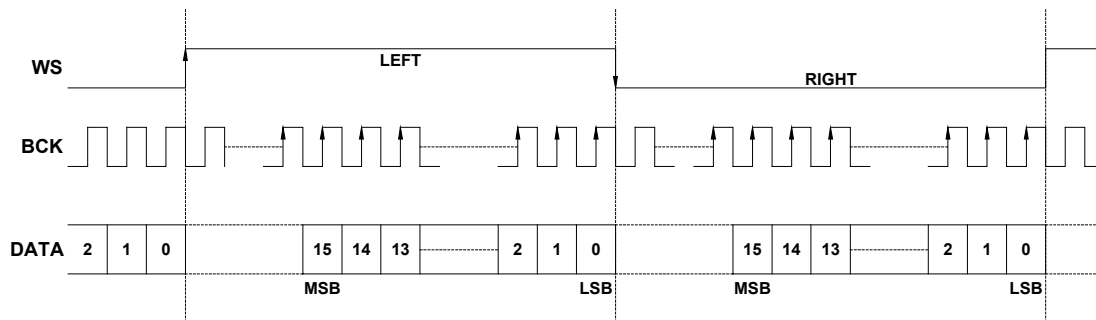

### APPLICATION INFORMATION

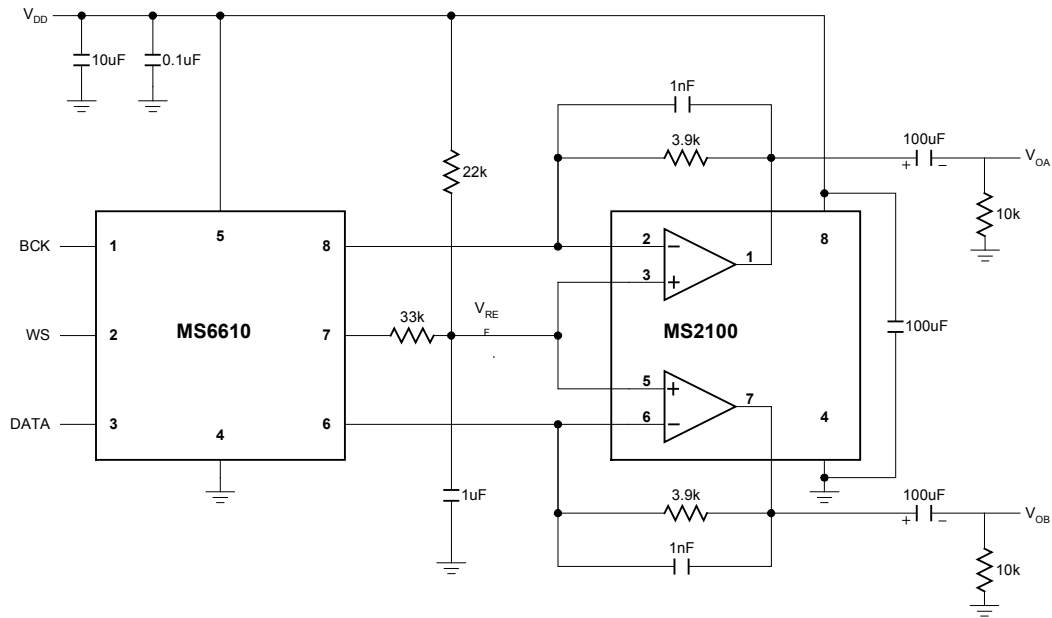
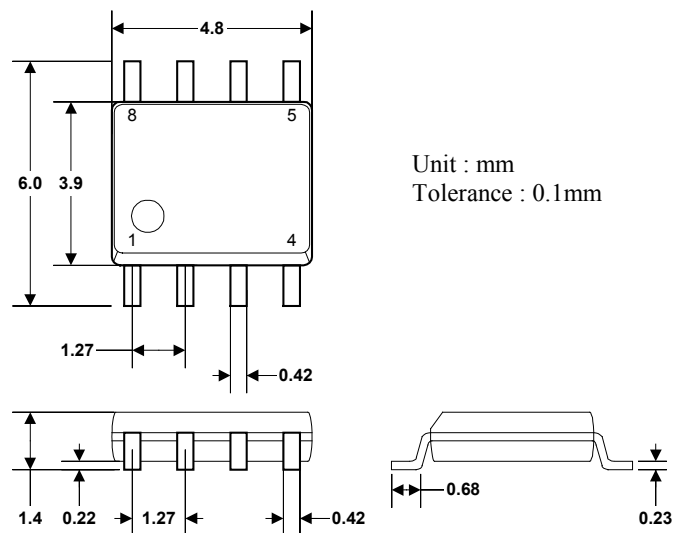
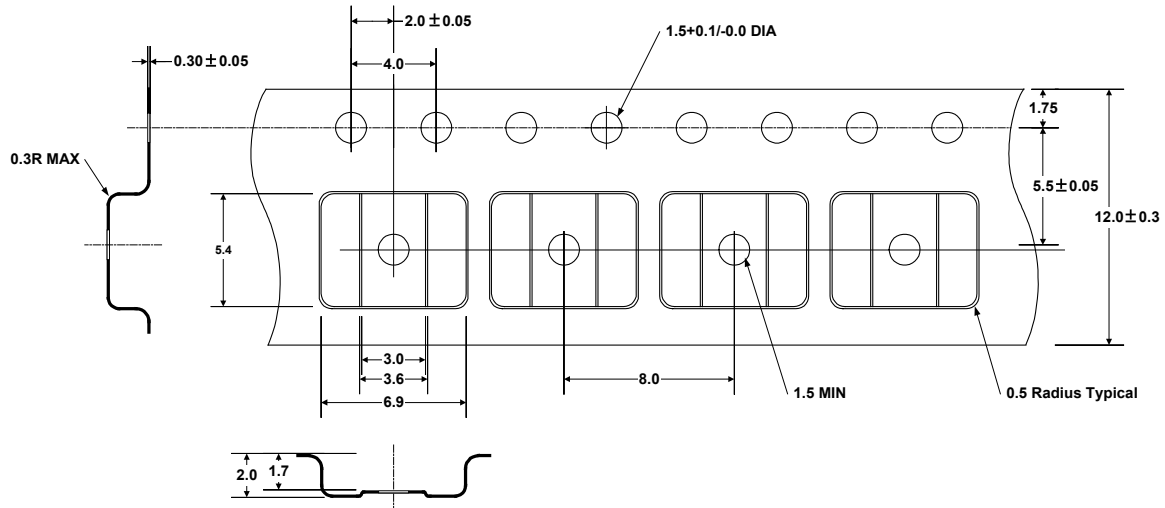

Fig.3 Example of application with MS6610 (audio DAC)

### EXTERNAL DIMENSIONS



### TAPE AND REEL (Unit : mm)



### ORDERING INFORMATION

Package	Part number	Packaging Marking	Transport Media
8-Pin SOP	MS6610BSTR	MS6610BS	2.5k Units Tape and Reel
8-Pin SOP	MS6610BSU	MS6610BS	100 Units Tube
8-Pin SOP (lead free)	MS6610BSGTR	MS6610BSG	2.5k Units Tape and Reel
8-Pin SOP (lead free)	MS6610BSGU	MS6610BSG	100 Units Tube

RoHS Compliance