

Description

The YB1509 is a high-power boost converter. An adjustable current limit, wide range of input voltage, and up to 40V of switch voltage are designed to drive white LEDs back-lighting for large LCD panel. It can drive up to 10 LEDs in series or 18 LEDs in parallel/series configuration.

The wide application VIN range makes YB1509 suitable for many types of battery applications such as Li-ions, Alkaline, or Sealed Lead Acid batteries. The adjustable inductor current optimizes the performance for different output drive capability by an external resistor.

The LED current is set by a resistor connected to **FB** pin. The On/Off duty with clock frequency from 1K to 100KHz at **EN** pin can control the LED brightness

Features

- 2V to 16V Input Voltage
- 40V Maximum Output Voltage
- Drive up to 18 White LEDs
- Adjustable Inductor Current
- 1 μ s Constant Off-time PFM Control
- 1KHz to 100KHz PWM Dimming Control

Applications

- PDA, Palmtops and Smart Phones
- LCD Monitor
- LCD TV
- Portable DVD player
- White LED backlighting
- GPS navigation system
- Handheld Game

Typical Application Circuit

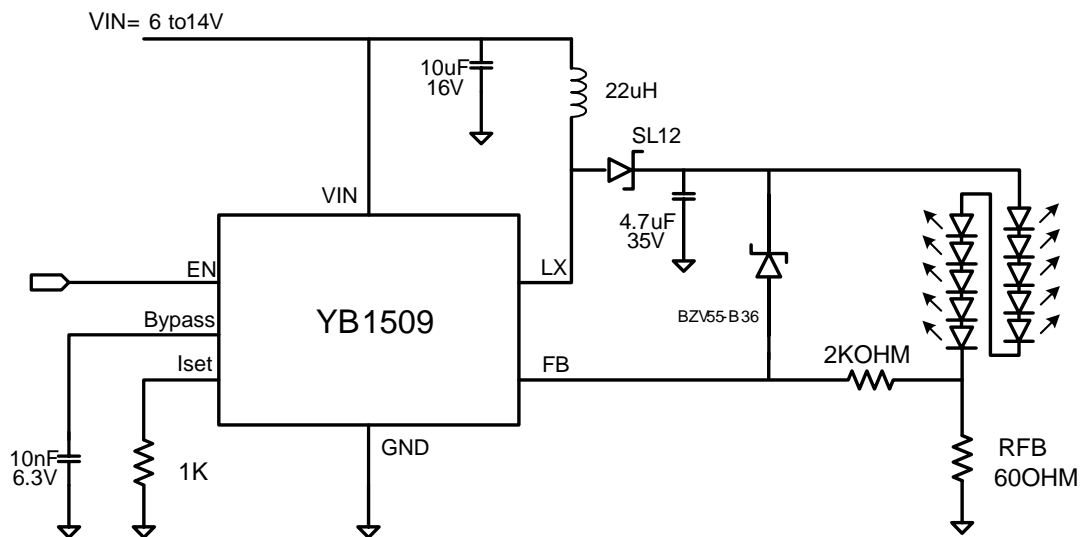

Figure 1. Typical application circuit

Pin Configuration

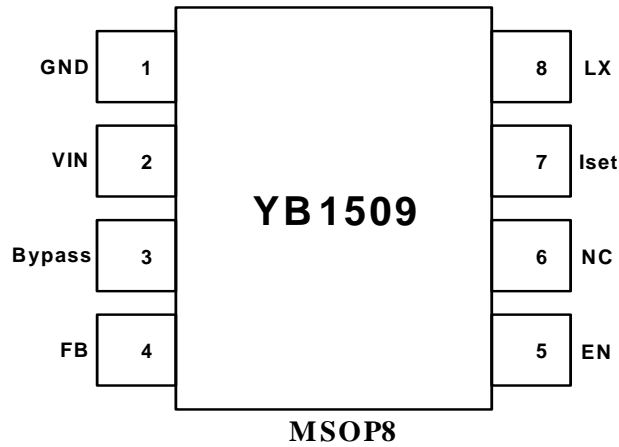

Figure 2. Pin configuration

Pin Description

Table 1

Pin	Name	Description
1	GND	Signal and power ground.
2	VIN	Input supply pin.
3	Bypass	Internal compensation usage. A 10nF bypass capacitor is recommended.
4	FB	Feedback input pin.
5	EN	Enable control input. Active high.
6	NC	No connect.
7	I _{SET}	Set inductor current.
8	LX	Switch pin, connect to external inductor.

Ordering Information

Order Number	Package Type	Supplied as	Package Marking
YB1509	MSOP-8	2500 units Tape & Reel	YB1509

Absolute Maximum Ratings

Supply Voltage.....-0.3V to 16V
 LX Switch Voltage.....-0.3V to 40V
 Junction Temperature Range..... +150
 Storage Temperature Range -65 to +150
 Lead Temperature..... +250

Recommended Operating Conditions

Input Supply Voltage..... 2.2V to 16V
 Operating Temperature..... -40 to +85

Electrical Characteristics

At $T_A=25^\circ\text{C}$, $V_{IN}=6\text{V}$, unless otherwise noted.

Table 2

Function Parameter	Conditions	Min	Typ	Max	Units
Input Voltage Range		2.2		16	V
V_{FB} Threshold Voltage		1.21	1.23	1.25	V
V_{FB} Pin Bias Current	$V_{FB}=1.23\text{V}$	180		250	nA
Quiescent Current	$V_{FB}=1.5\text{V}$, not switching			400	μA
Quiescent Current in shutdown	$V_{EN}=0\text{V}$			10	μA
Switching Off Time			1		μs
Switching On $V_{CE,SAT}$	$I_{SWITCH}=300\text{mA}$		220	330	mV
LX Leakage Current	$V_{FB}=1.5\text{V}$, $V_{LX}=40\text{V}$		1	10	μA
EN Logic Low Level	EN pin voltage low			0.4	V
EN Logic High Level	EN pin voltage high	1.8		V_{IN}	V
EN Input Bias Current	$V_{EN}=3\text{V}$		4.5	15	μA
EN Input Bias Current	$V_{EN}=0\text{V}$			1	μA
I_{SET} Source Current		6	8	10	μA
Inductor Peak Current	$R_{limit}=15\text{K}$, $V_{in}=12\text{V}$, $V_{out}=30\text{V}$, $I_{out} = 150\text{mA}$	1.4	1.5	1.6	A

Typical Characteristics

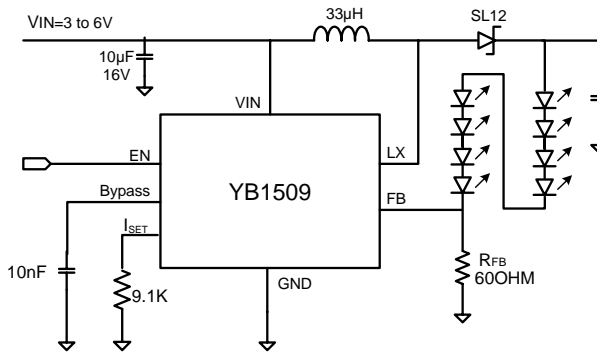

Figure 3. 8 LEDs in a Series

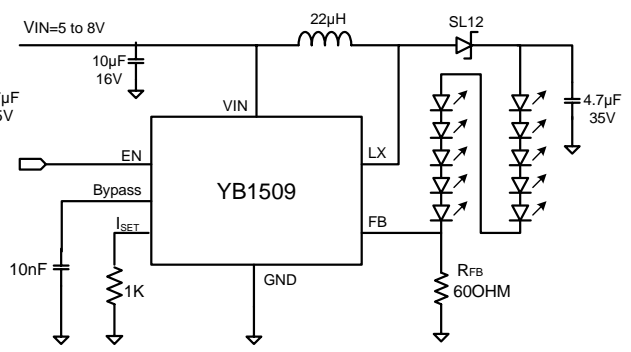

Figure 4. 10 LEDs in a Series

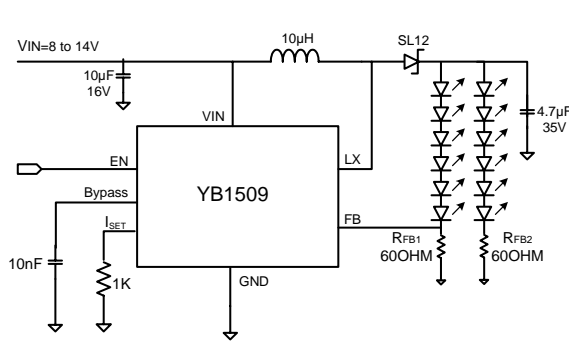

Figure 5. 2 Legs of 6 LEDs in a Series

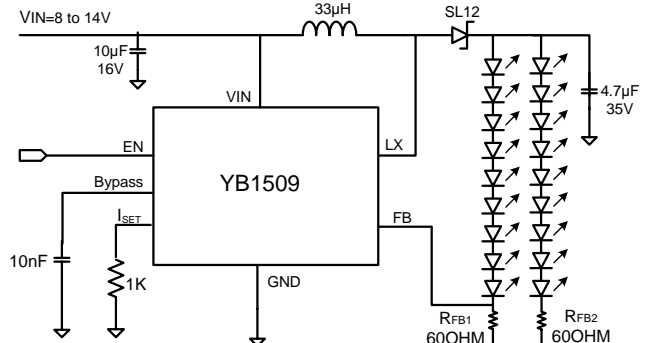
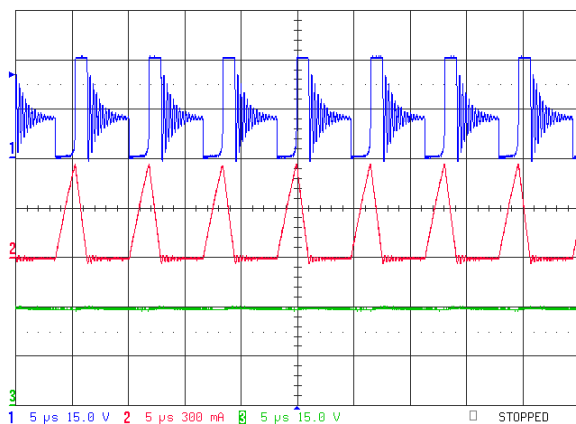
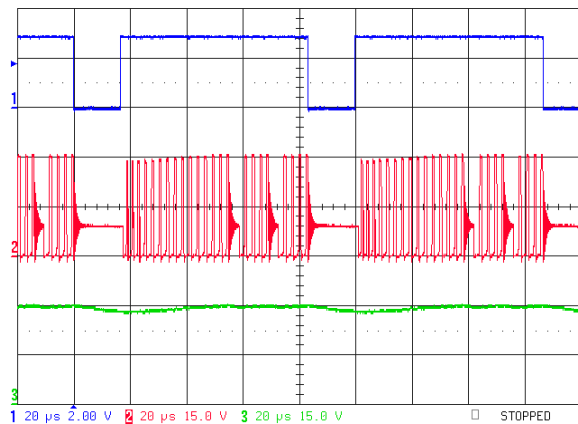

Figure 6. 2 Legs of 9 LEDs in a Series



CH1: LX CH2: Inductor Current CH3: V_{OUT} (18 LEDs)

Figure 7. Typical Switching Waveform



CH1: EN CH2: LX CH3: V_{OUT} (18 LEDs)

Figure 8. PWM Brightness Control by EN

Functional Block Diagram

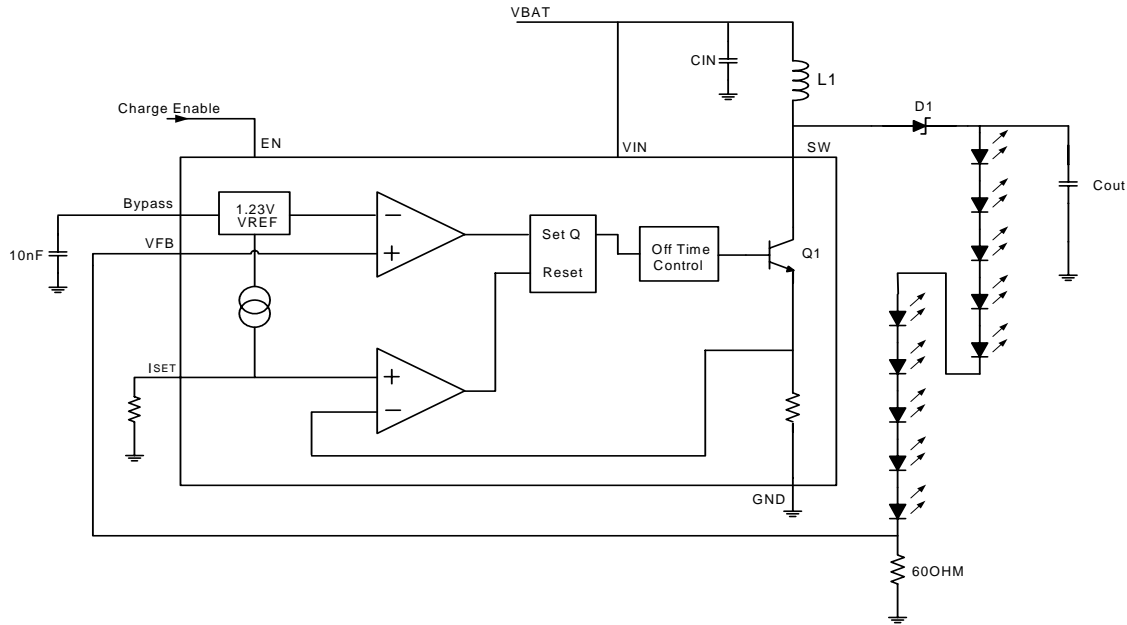

Figure 9. Block Diagram

Functional Description

The YB1509 is a constant current high-power white LED driver. It can drive up to 10 LEDs in series or 18 LEDs in parallel/series configuration. The IC uses a peak current, $1\mu\text{s}$ off-time PFM scheme. The inductor current ramp up when power NPN is turn on. Once the inductor current reaches the preset value determined by the I_{SET} pin, output power NPN is shut off and the energy stored in inductor is delivered to the output capacitor. Once the discharge cycle is completed, the power NPN is on again. If the FB voltage has not yet reached the designated value of 1.23V, the inductor current will be charged up again. This charging and discharging sequence will repeat itself until the FB voltage gets to the designated value and triggers the on-off

latch to hold off the power NPN regardless the inductor current value.

LED Current and Brightness control

The LED's current is set by the resistor connected at FB pin to GND using:

$$I_{LED} = \frac{1.23V}{R_{FB}}$$

LED's brightness is accomplished by applying a PWM signal with a frequency range between 100Hz and 50KHz to the EN pin.

Inductor Current Set

Using a resistor connected from I_{SET} to GND is able to set inductor current. An $8\mu\text{A}$ current source is coming out of the YB1509

and going through the I_{SET} resistor to ground. The higher the I_{SET} pin voltage, the larger the peak inductor current is built up.

Application Information

Enable/Shutdown

The YB1509 comes with an active-high enable pin that allows the white LED driver to be enabled. Forcing the enable pin low disables the chip and puts it into the shutdown mode. This pin cannot be left floating; as it may cause an undetermined state.

Input/Output Capacitor

It is recommended to use a $10\mu\text{F}$ capacitor on the YB1509 input and a $4.7\mu\text{F}$ capacitor on the output. Higher capacitance is allowed to reduce the voltage and current ripple. Choose low ESR capacitors for the output to minimize output ripple. Multilayer ceramic capacitors are good choice for the input and output capacitor.

Inductor

The appropriate inductor for a given application is calculated using the following equation:

$$L = \left(\frac{V_{OUT} - V_{IN,MIN} + V_D}{I_{SET}} \right) T_{OFF}$$

Where V_D is the schottky diode voltage, I_{SET} is the setting for inductor current, and T_{OFF} is the switch off time designed for $1\mu\text{s}$. When using this equation be sure to use the minimum input voltage for the

application, such as for battery-powered application.

Choosing inductor with low ESR decrease power losses and increase efficiency.

Diode selection

To maintain high efficiency, the average current rating of the schottky diode should be large than the peak inductor current. Schottky diode with a low forward drop and fast switching speeds are ideal for increase efficiency in portable application. Choose a reverse breakdown of the schottky diode large than the output voltage.

Thermal Consideration:

When YB1509 is set to handle high switch current will result in internal power dissipation and thus generating heat. Always beware the amount of power dissipated during operation. To resolve the thermal built up issue, reduce resistance at I_{SET} which lower the peak switch current.

Layout consideration

The input capacitor C_{IN} must be placed close to the IC. This will reduce copper trace resistance which effect input voltage ripple of the IC. The output capacitor, C_{OUT} , should also be placed close to the IC. Any copper trace connections for the C_{OUT} capacitor can increase the series resistance, which directly effect output voltage ripple. The feedback resistor should be kept close to the FB pin to minimize copper trace connections that can inject noise into the system. The ground

connection for the feedback resistor network should connect directly to an analog ground plane. Trace connections made to the inductor and schottky diode

should be short and wider for reducing power dissipation and increase overall efficiency.

Package Information

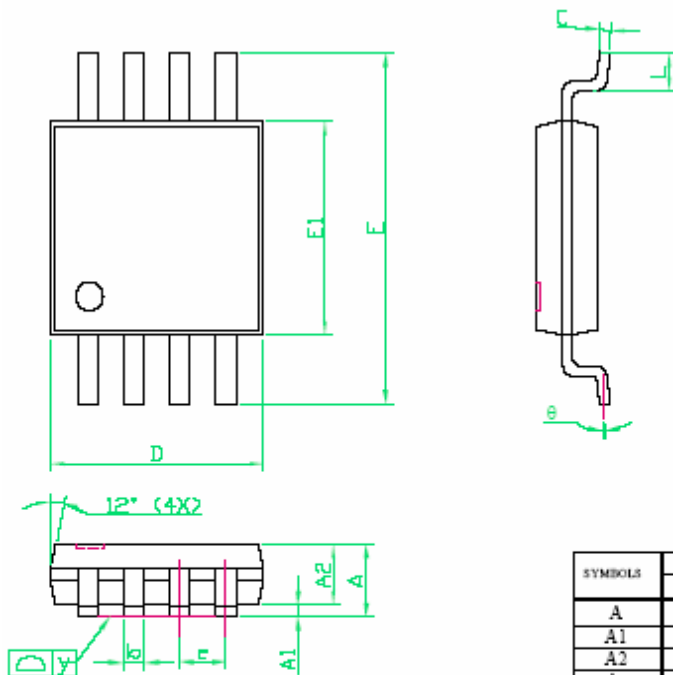

SYMBOLS	DIMENSIONS IN MILLIMETER			DIMENSIONS IN INCH		
	MIN	NOM	MAX	MIN	NOM	MAX
A	0.81	0.95	1.10	0.032	0.0375	0.043
A1	0.05	0.09	0.15	0.002	0.004	0.006
A2	0.76	0.86	0.97	0.030	0.034	0.038
b	0.28	0.30	0.38	0.011	0.012	0.015
C	0.13	0.15	0.23	0.005	0.006	0.009
D	2.90	3.00	3.10	0.114	0.118	0.122
E	4.70	4.90	5.10	0.185	0.193	0.201
E1	2.90	3.00	3.10	0.114	0.118	0.122
e	---	0.65	---	---	0.026	---
L	0.40	0.53	0.66	0.016	0.021	0.026
y	---	---	0.10	---	---	0.004
θ	0°	---	6°	0°	---	6°