

## Description

The YB1519 is a high-power boost converter. An adjustable current limit, wide range of input voltage, and up to 40V of switch voltage are designed to drive white LEDs back-lighting for large LCD panel. It can drive up to 10 LEDs in series or 18 LEDs in parallel/series configuration.

The wide application VIN range makes YB1519 suitable for many types of battery applications such as Li-ions, Alkaline, or Sealed Lead Acid batteries. The adjustable inductor current optimizes the performance for different output drive capability by an external resistor.

The LED current is set by a resistor connected to **FB** pin. The On/Off duty with clock frequency from 1K to 100KHz at **EN** pin can control the LED brightness

## Typical Application Circuit

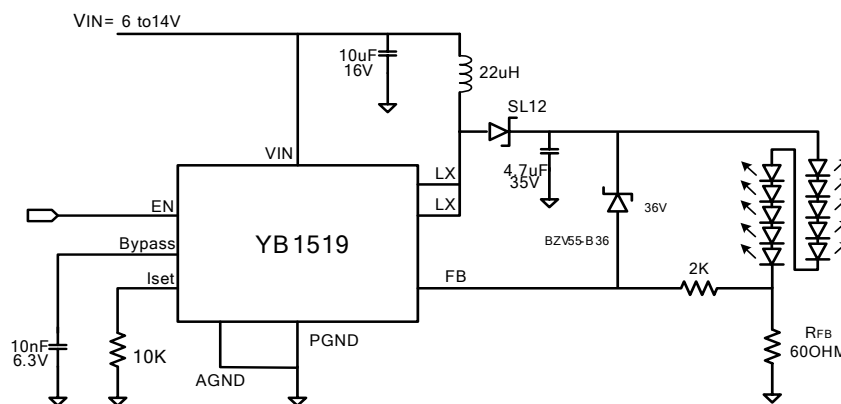

Figure 1. Typical application circuit

## Features

- 2V to 16V Input Voltage
- 40V Maximum Output Voltage
- Drive up to 18 White LEDs
- Adjustable Inductor Current
- 1 $\mu$ s Constant Off-time PFM Control
- 1KHz to 100KHz PWM Dimming Control

## Applications

- High Power WLED Backlight Solution
- LCD Monitor
- LCD TV
- Car TV, Portable DVD
- GPS navigation system
- Handheld Game

## Pin Configuration

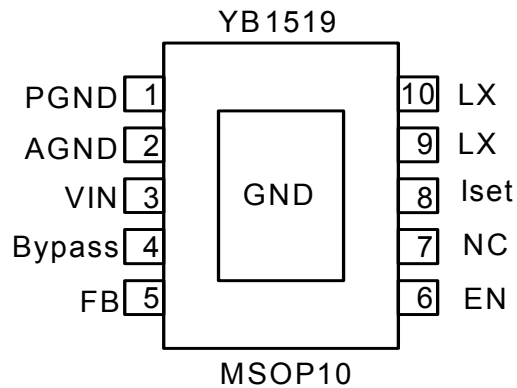

Figure 2. Pin configuration

## Pin Description

Table 1

| Pin | Name   | Description   |
|-----|--------|---|
| 1   | PGND   | Power ground, tie solidly to system ground of the board.                        |
| 2   | AGND   | Analog ground, tie solidly to system ground of the board.                       |
| 3   | VIN    | Input supply pin. Must be locally bypassed with a capacitor to eliminate noise. |
| 4   | Bypass | Internal compensation usage. A 10nF bypass capacitor is recommended.            |
| 5   | FB     | Feedback input pin.   |
| 6   | EN     | Enable control pin. Active high.  |
| 7   | NC     | No connection.  |
| 8   | Iset   | Tie a resistor to ground to set inductor current.                               |
| 9   | LX     | Switch pin, connect to external inductor.                                       |
| 10  | LX     | Switch pin, connect to external inductor.                                       |

## Ordering Information

| Order Number | Package Type | Supplied as            | Package Marking |
|--------------|--------------|------------------------|-----------------|
| YB1519       | MSOP-10      | 2500 Units Tape & Reel | YB1519          |

## Absolute Maximum Ratings

Supply Voltage ..... -0.3V to 16V  
 LX Switch Voltage ..... -0.3V to 40V  
 Junction Temperature Range ..... +150°C  
 Storage Temperature Range ..... -65°C to +150°C  
 Lead Temperature ..... +250°C

## Recommended Operating Conditions

Input Supply Voltage ..... 2.2V to 16V  
 Operating Temperature ..... -40°C to +85°C

## Electrical Characteristics

At  $T_A=25^\circ\text{C}$ ,  $V_{IN}=6\text{V}$ , unless otherwise noted.

**Table 2**

| Function Parameter            | Conditions   | Min  | Typ  | Max      | Units         |
|-------------------------------|--|------|------|----------|---------------|
| Input Voltage Range           |  | 2.2  |      | 16       | V             |
| $V_{FB}$ Threshold Voltage    |  | 1.21 | 1.23 | 1.25     | V             |
| $V_{FB}$ Pin Bias Current     | $V_{FB}=1.23\text{V}$  | 180  |      | 250      | nA            |
| Quiescent Current             | $V_{FB}=1.5\text{V}$ , not switching   |      |      | 400      | $\mu\text{A}$ |
| Quiescent Current in shutdown | $V_{EN}=0\text{V}$   |      |      | 10       | $\mu\text{A}$ |
| Switching Off Time            |  |      | 1    |          | $\mu\text{s}$ |
| Switching On $V_{CE,SAT}$     | $I_{SWITCH}=300\text{mA}$  |      | 220  | 330      | mV            |
| LX Leakage Current            | $V_{FB}=1.5\text{V}$ , $V_{LX}=40\text{V}$   |      | 1    | 10       | $\mu\text{A}$ |
| EN Logic Low Level            | EN pin voltage low   |      |      | 0.4      | V             |
| EN Logic High Level           | EN pin voltage high  | 1.8  |      | $V_{IN}$ | V             |
| EN Input Bias Current         | $V_{EN}=3\text{V}$   |      | 4.5  | 15       | $\mu\text{A}$ |
| EN Input Bias Current         | $V_{EN}=0\text{V}$   |      |      | 1        | $\mu\text{A}$ |
| $I_{SET}$ Source Current      |  | 6    | 8    | 10       | $\mu\text{A}$ |
| Inductor Peak Current         | $R_{limit}=15\text{K}$ , $V_{in}=12\text{V}$ , $V_{out}=30\text{V}$ , $I_{out} = 150\text{mA}$ | 1.4  | 1.5  | 1.6      | A             |

## Typical Characteristics

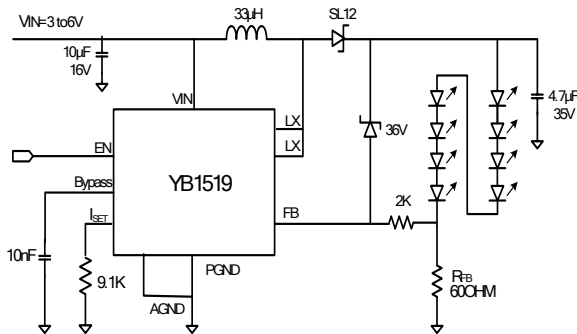

Figure 3. 8 LEDs in a Series

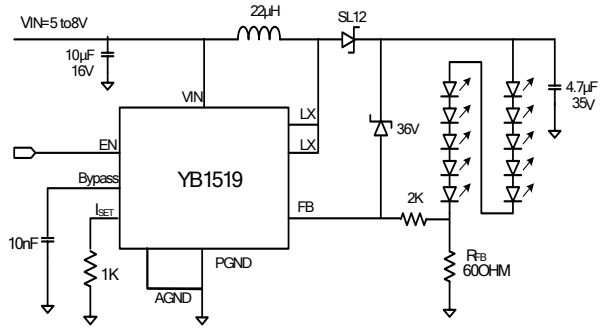

Figure 4. 10 LEDs in a Series

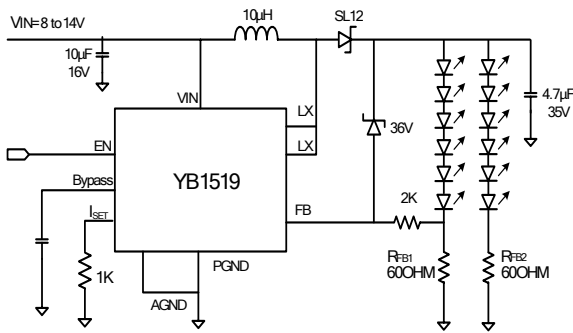

Figure 5. 2 Legs of 6 LEDs in a Series

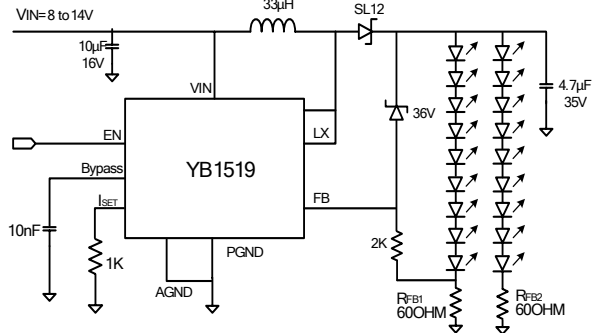
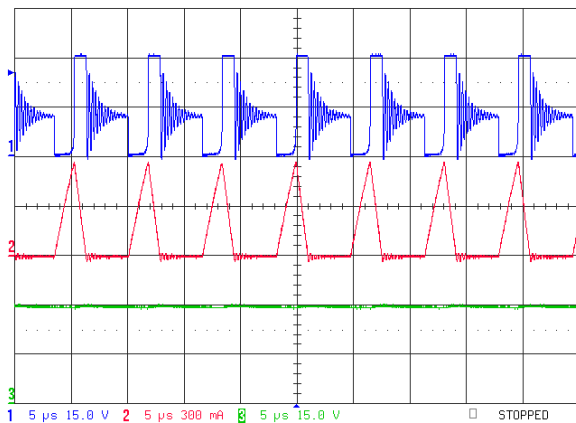
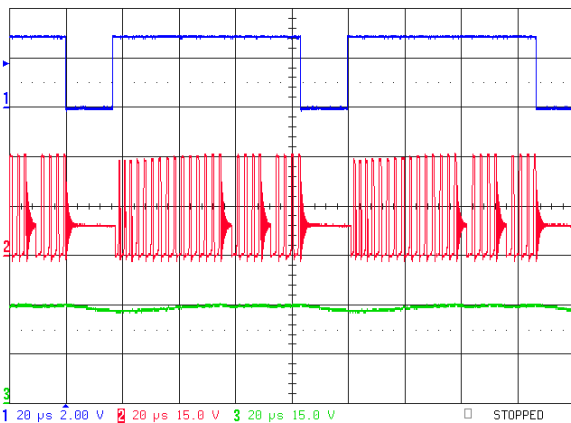

Figure 6. 2 Legs of 9 LEDs in a Series



CH1: LX CH2: Inductor Current CH3:  $V_{OUT}$  (18 LEDs)

Figure 7. Typical Switching Waveform



CH1: EN CH2: LX CH3:  $V_{OUT}$  (18 LEDs)

Figure 8. PWM Brightness Control by EN

## Functional Block Diagram

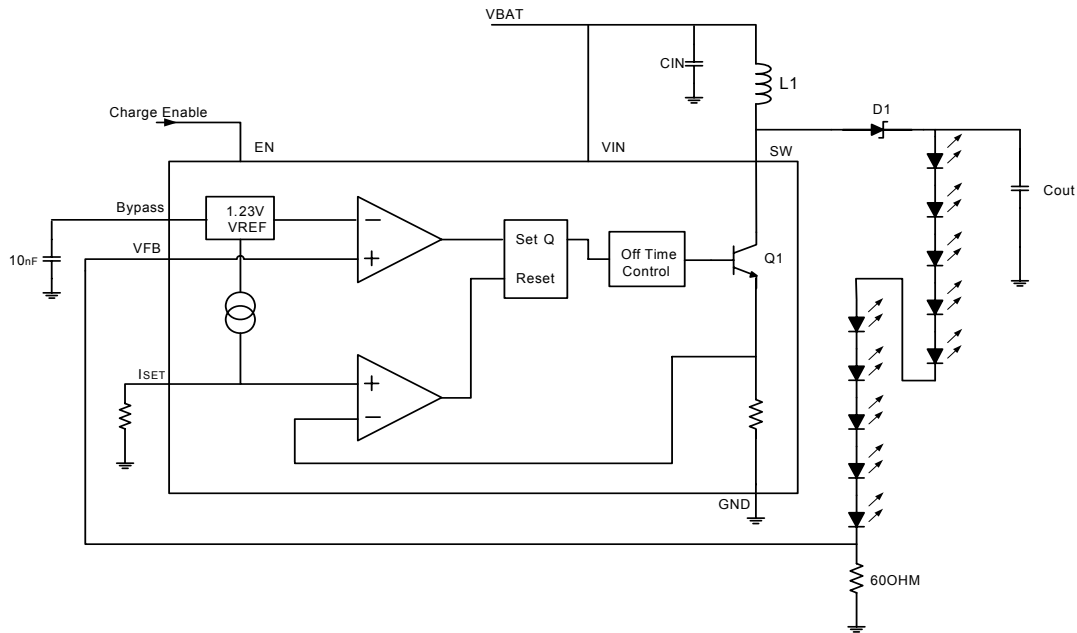

Figure 9. Block Diagram

## Functional Description

The YB1519 is a constant current high-power white LED driver. It can drive up to 10 LEDs in series or 18 LEDs in parallel/series configuration. The IC uses a peak current,  $1\mu\text{s}$  off-time PFM scheme. The inductor current ramp up when power NPN is turn on. Once the inductor current reaches the preset value determined by the  $I_{\text{SET}}$  pin, output power NPN is shut off and the energy stored in inductor is delivered to the output capacitor. Once the discharge cycle is completed, the power NPN is on again. If the FB voltage has not yet reached the designated value of 1.23V, the inductor current will be charged up again. This charging and discharging sequence will repeat itself until the FB voltage gets to the designated value and triggers the on-off

latch to hold off the power NPN regardless the inductor current value.

### LED Current and Brightness control

The LED's current is set by the resistor connected at FB pin to GND using:

$$I_{LED} = \frac{1.23V}{R_{FB}}$$

LED's brightness is accomplished by applying a PWM signal with a frequency range between 100Hz and 50KHz to the EN pin.

### Inductor Current Set

Using a resistor connected from  $I_{\text{SET}}$  to

GND is able to set inductor current. An 8μA current source is coming out of the YB1519 and going through the I<sub>SET</sub> resistor to ground. The higher the I<sub>SET</sub> pin voltage, the larger the peak inductor current is built up.

## Application Information

### Enable/Shutdown

The YB1519 comes with an active-high enable pin that allows the white LED driver to be enabled. Forcing the enable pin low disables the chip and puts it into the shutdown mode. This pin cannot be left floating; as it may cause an undetermined state.

### Input/Output Capacitor

It is recommended to use a 10μF capacitor on the YB1519 input and a 4.7μF capacitor on the output. Higher capacitance is allowed to reduce the voltage and current ripple. Choose low ESR capacitors for the output to minimize output ripple. Multilayer ceramic capacitors are good choice for the input and output capacitor.

### Inductor

The appropriate inductor for a given application is calculated using the following equation:

$$L = \left( \frac{V_{OUT} - V_{IN,MIN} + V_D}{I_{SET}} \right) T_{OFF}$$

Where V<sub>D</sub> is the schottky diode voltage, I<sub>SET</sub> is the setting for inductor current, and T<sub>OFF</sub> is the switch off time designed for 1μs.

When using this equation be sure to use the minimum input voltage for the application, such as for battery-powered application.

Choosing inductor with low ESR decrease power losses and increase efficiency.

### Diode selection

To maintain high efficiency, the average current rating of the schottky diode should be large than the peak inductor current. Schottky diode with a low forward drop and fast switching speeds are ideal for increase efficiency in portable application. Choose a reverse breakdown of the schottky diode large than the output voltage.

### Thermal Consideration:

When YB1519 is set to handle high switch current will result in internal power dissipation and thus generating heat. Always beware the amount of power dissipated during operation. To resolve the thermal built up issue, reduce resistance at I<sub>SET</sub> which lower the peak switch current.

### Layout consideration

The input capacitor C<sub>IN</sub> must be placed close to the IC. This will reduce copper trace resistance which effect input voltage ripple of the IC. The output capacitor, C<sub>OUT</sub>, should also be placed close to the IC. Any copper trace connections for the C<sub>OUT</sub> capacitor can increase the series resistance, which directly effect output voltage ripple. The feedback resistor should be kept close to the FB pin to

minimize copper trace connections that can inject noise into the system. The ground connection for the feedback resistor network should connect directly to an analog ground plane. Trace connections

made to the inductor and schottky diode should be short and wider for reducing power dissipation and increase overall efficiency.

## Package Information

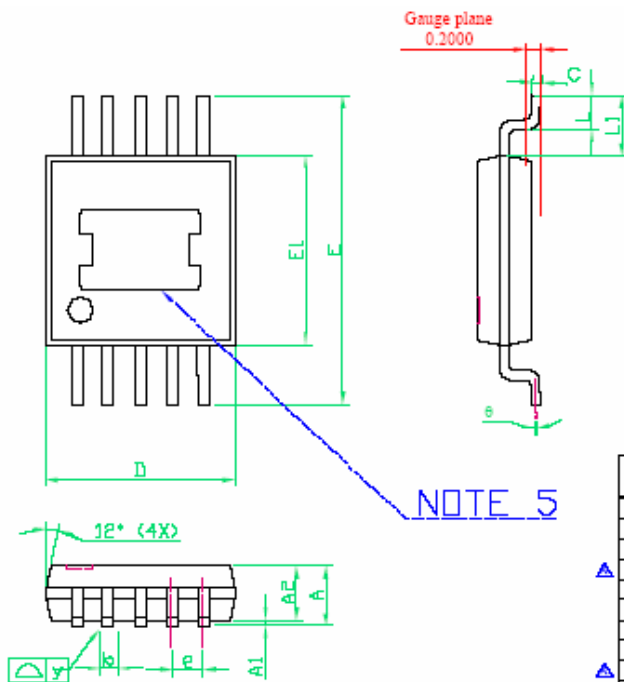

| SYMBOLS | DIMENSIONS IN MILLIMETER |      |       | DIMENSIONS IN INCH |        |       |
|---------|--------------------------|------|-------|--------------------|--------|-------|
|         | MIN                      | NOM  | MAX   | MIN                | NOM    | MAX   |
| A       | 0.76                     | 0.86 | 1.07  | 0.030              | 0.034  | 0.042 |
| A1      | 0.000                    | ---  | 0.100 | 0.000              | ---    | 0.004 |
| A2      | 0.76                     | 0.86 | 0.97  | 0.030              | 0.034  | 0.038 |
| b       | 0.15                     | 0.20 | 0.30  | 0.006              | 0.008  | 0.012 |
| C       | 0.13                     | 0.15 | 0.23  | 0.005              | 0.006  | 0.009 |
| D       | 2.90                     | 3.00 | 3.10  | 0.114              | 0.118  | 0.122 |
| E       | 4.70                     | 4.90 | 5.10  | 0.185              | 0.193  | 0.201 |
| E1      | 2.90                     | 3.00 | 3.10  | 0.114              | 0.118  | 0.122 |
| e       | ---                      | 0.50 | ---   | ---                | 0.0197 | ---   |
| L       | 0.40                     | 0.53 | 0.66  | 0.016              | 0.021  | 0.026 |
| y       | ---                      | ---  | 0.10  | ---                | ---    | 0.004 |
| ø       | 0*                       | ---  | ø*    | 0*                 | ---    | ø*    |
| L1      | 0.85                     | 0.95 | 1.05  | 0.033              | 0.037  | 0.041 |

Note 5. X = 1.48mm, Y = 1.34mm