

### Description

The YB1518 is a step-up DC-DC converter; operates as current source to drive up to 6 white LEDs(VIN at 3.0V) or 8 LEDs(VIN at 3.5V) or 9 LEDs(VIN at 3.5V) in series. Series connecting of the LEDs provides identical LED currents resulting in uniform brightness and eliminating the need for ballast resistors. The light intensity of these LEDs is proportional to the current passing through them. The YB1518 switches at a fixed frequency of ~930KHz, allowing the use of tiny, low profile inductors and capacitors to minimize footprint and cost in space consideration applications for cellular phone backlighting or other hand held equipment.

The YB1518 can drive up to 9 white LEDs from a single Li-Ion battery. The wide input voltage range from 2.7V to 7V is ideal for portable applications with higher conversion efficiency. To control LED brightness, the LED current can be pulsed by applying a PWM (pulse width modulated) signal with a frequency range of 100Hz to 1KHz to the CTRL pin.

YB1518 has integrated Latched Over Voltage Protection that prevents damage to the device in case of a high impedance output due to faulty LED or open circuit caused by abnormal conditions.

### Features

- Built-in internal switch
- 2.7V to 7V input range
- <1uA shutdown current
- PWM dimming control 100Hz to 1KHz
- Analog dimming control
- Internal Soft Start
- Drives up to 9 white LEDs(VIN at 3.5V)
- Over voltage protection 34V
- Small 5-Lead SOT-23 package
- 100mV Low Reference Voltage

### Applications

- LCD Display Module
- White LED Backlighting
- PDAs, GPS terminals
- Digital Cameras
- Cellular Phone
- Electronic Books
- Portable Applications

### Typical Application Circuit

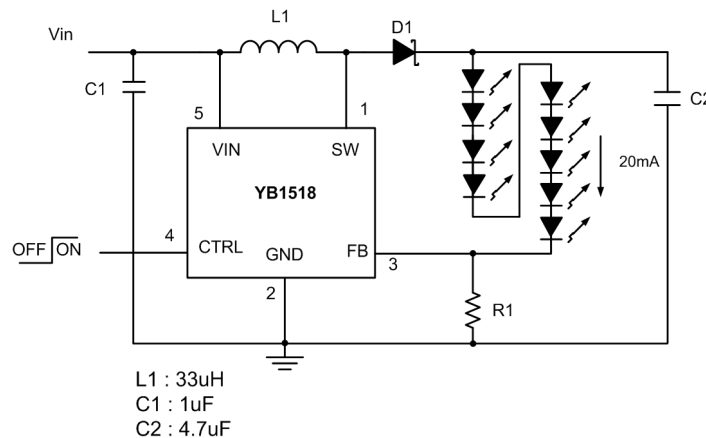

Figure 1: Typical Application Circuit

### Pin Configuration

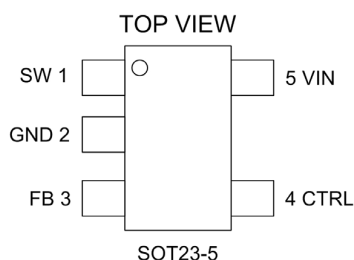

Figure 2: YB1518 Pin Configuration

### Pin Description

Table 1

Pin	NAME	Description
1	SW	Switching Pin. This is the collector of the internal NPN power switch. Connect to inductor and diode. Minimize the metal trace area connected to this pin to reduce EMI.
2	GND	Ground Pin. Connect directly to local ground plane.
3	FB	Feedback Pin. Reference voltage is 100mV. Connect LEDs and a resistor at this pin. LED current is determined by the resistance and CTRL voltage.
4	CTRL	Shutdown Pin and Dimming Control pin. VCTRL > 1.8V generates full-scale LED current VCTRL < 0.4V chip is off Switching from 0.4V to 2.0V, PWM duty cycle controls the LED current
5	VIN	Input Supply Pin. Bypass this pin with a capacitor as close to the device as possible

### Ordering Information

Order Number	Supplied as	Package Marking
YB1518ST25	3000 units Tape & Reel	Please contact sales representative

### Absolute Maximum Ratings

VIN.....	9V
SW Voltage.....	36V
FB Voltage.....	5V
CTRL Voltage.....	5V
Maximum Junction Temp, T <sub>J</sub> .....	150°C
Lead Temperature (Slokering 10 sec).....	300°C
Thermal Resistance.....	195°C

### Recommended Operating Conditions

Operating Temperature.....	-40°C~85°C
Supply Voltage.....	2.7 V~7V
SW Voltage.....	32V

### Electricity Characteristics

(T<sub>A</sub>=25°C, V<sub>in</sub>=3.3V, C<sub>in</sub>=1uF C<sub>out</sub>=10uF unless otherwise noted) Table 3

Symbol	Function Parameter	Test Conditions	Min	Typ	Max	Units
V <sub>in</sub>	Input Voltage Range		2.7		7	V
IQ (Quiescent Current)	Not Switching	V <sub>FB</sub> = 0.3V	1.2	1.5	1.7	mA
	Shutdown	CTRL = 0V		0.3	1	uA
V <sub>FB</sub>	Feedback Voltage	I <sub>out</sub> =20mA, V <sub>out</sub> =12.5V Circuit of Figure 1	90	100	110	mV
I <sub>CL</sub>	Switch Current Limit	100% duty cycle	200	230		mA
		40% duty cycle		180		mA
I <sub>B</sub>	FB Pin Bias Current	V <sub>FB</sub> =100mV			1	uA
FRSW	Switching Frequency		900	930	960	KHz
DTMX	Maximum Duty Cycle				85	%
DTMN	Minimum Duty Cycle		20		25	%
V <sub>SAT</sub>	Switch V <sub>cesat</sub>	At I <sub>sw</sub> = 200mA			180	mV
I <sub>LKG</sub>	Switch Leakage Current	Ctrl = 0.3V			1	uA
V <sub>CTL</sub>	V <sub>CTRL</sub> for Full LED Current	Full On	1.7			V
		Full Off			0.3	V
I <sub>CTL</sub>	CTRL Pin Bias Current	Ctrl = 2V		40		uA
OVP	Over Voltage Protection			34		V
θ <sub>JA</sub>	Thermal Resistance			220		°C/W

### Note:

Absolute maximum ratings are limits beyond which damage to the device may occur. The maximum allowable power dissipation is a function of maximum junction temperature, T<sub>J(max)</sub>, the junction to ambient thermal resistance, θ<sub>JA</sub>, and the ambient temperature. The maximum allowable power dissipation at any ambient temperature is calculated using: PD(MAX)= [T<sub>J(max)</sub>-T<sub>A</sub>]/θ<sub>JA</sub>. Exceeding the maximum allowable power dissipation will cause excessive die temperature. All limits at temperature extremes are guaranteed via correlation using standard statistical methods

**Typical Performance Characteristics**

Condition : VIN 2.8V ; 4.4V / VCTRL: 3V

VOUT ; 3pcs white LEDs

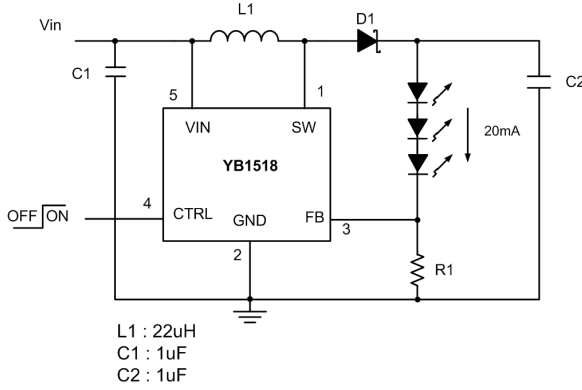

Condition : Vin 2.8V ; 4.4V / Vctrl : 3V

VOUT ; 4pcs white LEDs

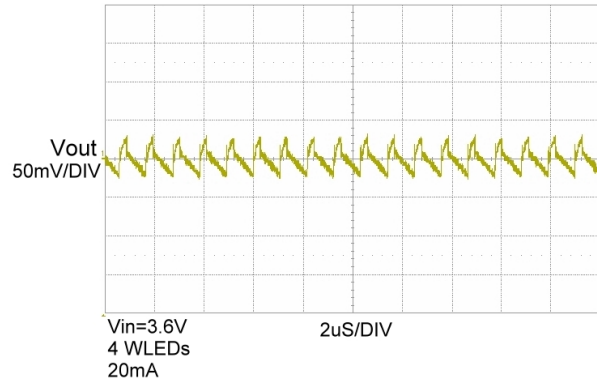
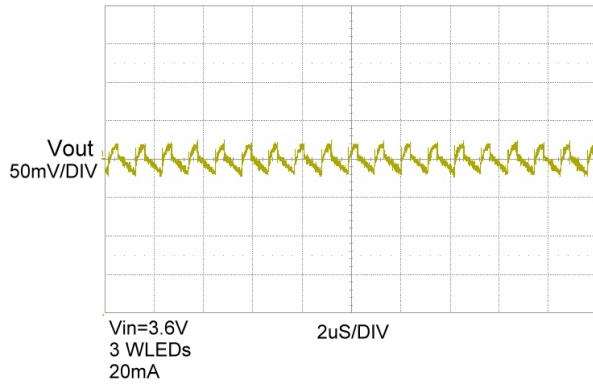
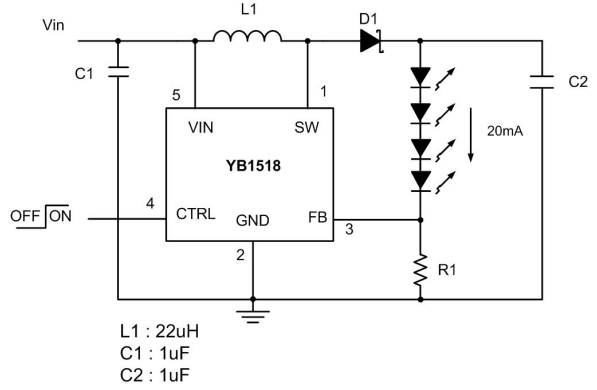

Efficiency vs Vin (3WLEDs)

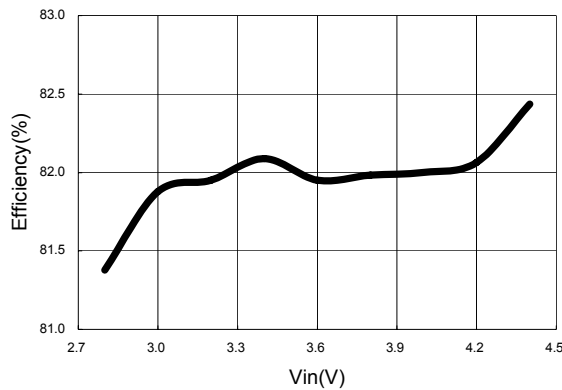

Efficiency vs Vin (4WLEDs)

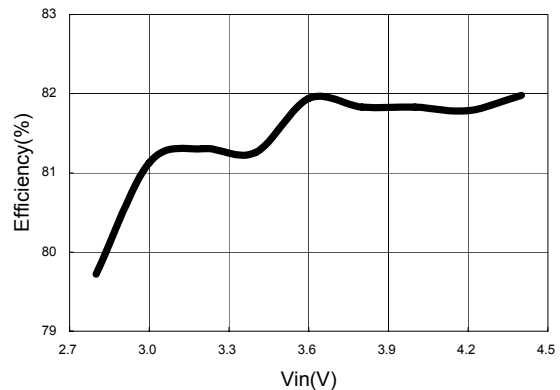

Condition : Vin 2.8V ; 4.4V / Vctrl : 3V  
VOUT ; 5pcs white LEDs

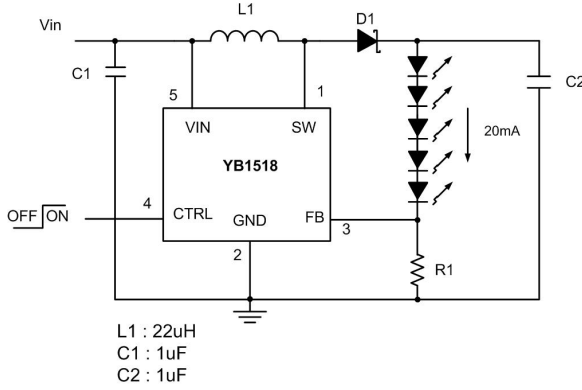

Condition : Vin 2.8V ; 4.4V / Vctrl : 3V  
VOUT ; 6pcs white LEDs

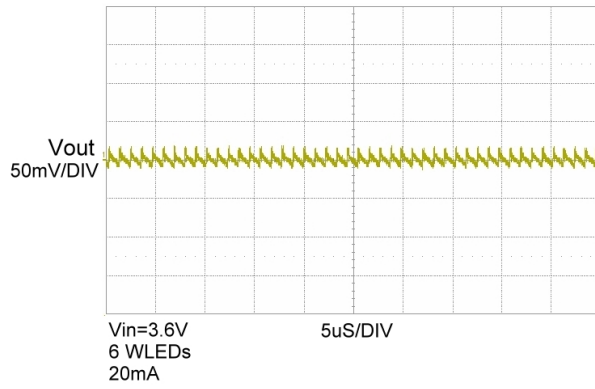
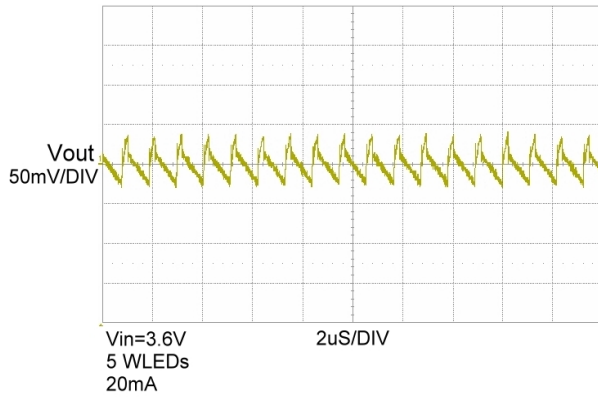
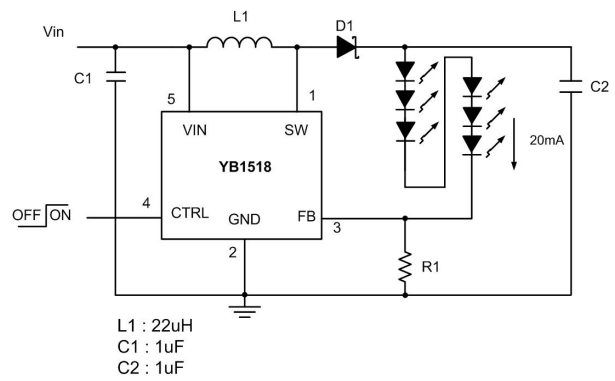

Efficiency vs Vin (5WLEDs)

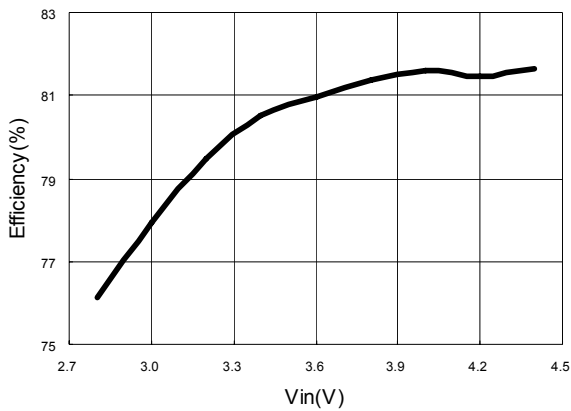

Efficiency vs Vin (6WLEDs)

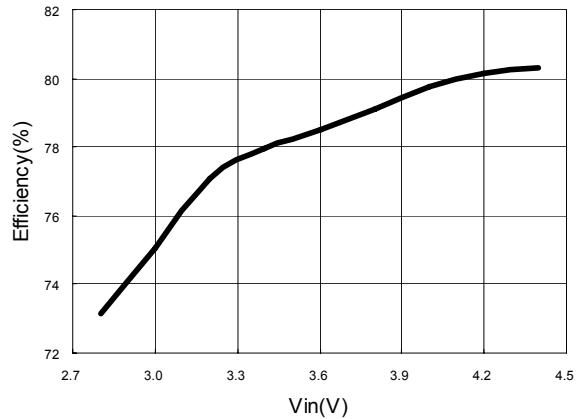

Condition : Vin 3.0V ;4.4V / Vctrl : 3V

VOUT ; 7pcs white LEDs

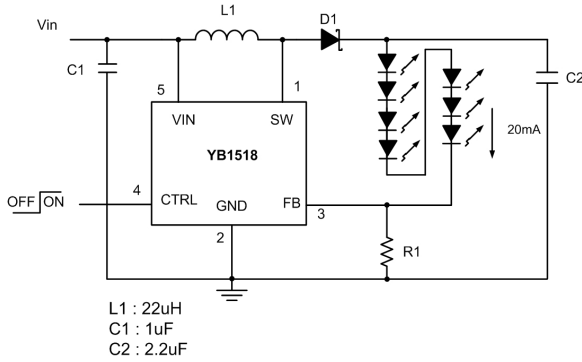

Condition : Vin 3.0V ; 4.4V / Vctrl : 3V

VOUT ; 8pcs white LEDs

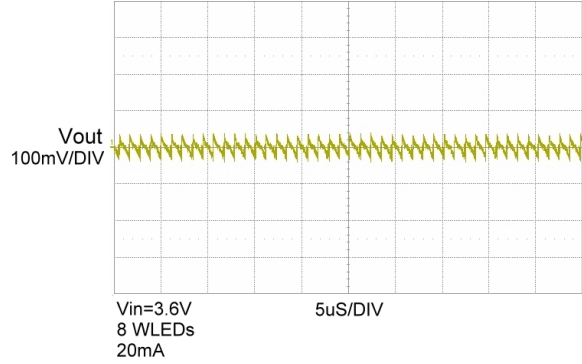
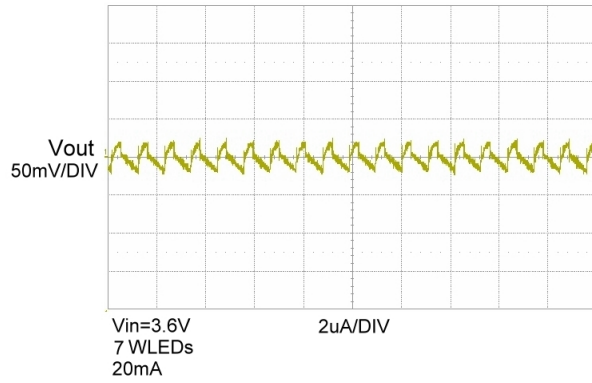
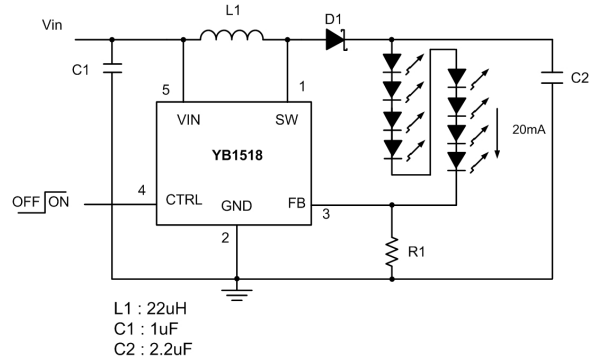

Efficiency vs Vin (7WLEDs)

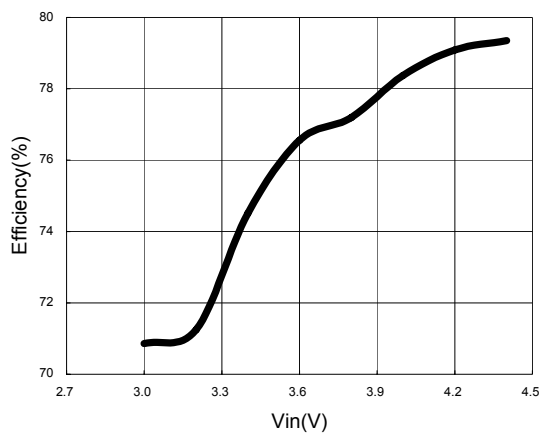

Efficiency vs Vin (8WLEDs)

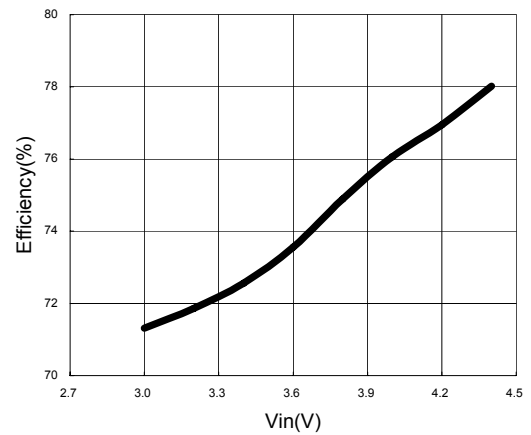

Condition : Vin 3.4V ; 6.0V / Vctrl : 3V

VOUT ; 9pcs white LEDs

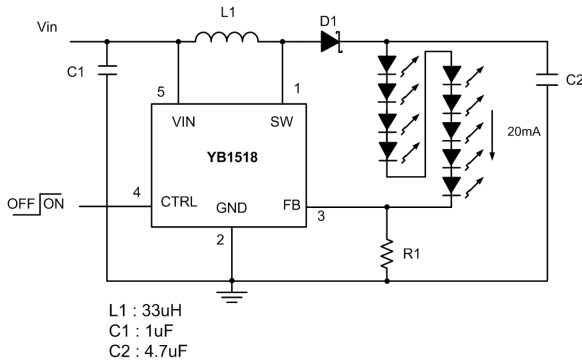

Efficiency vs Vin (9WLEDs)

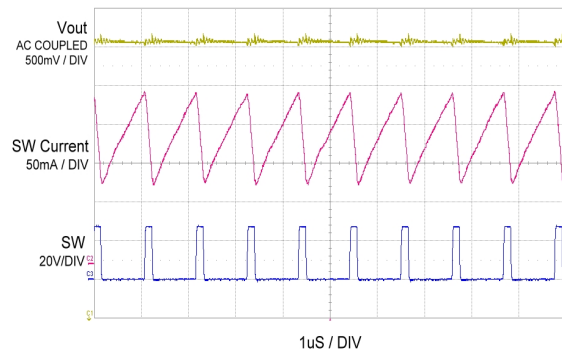
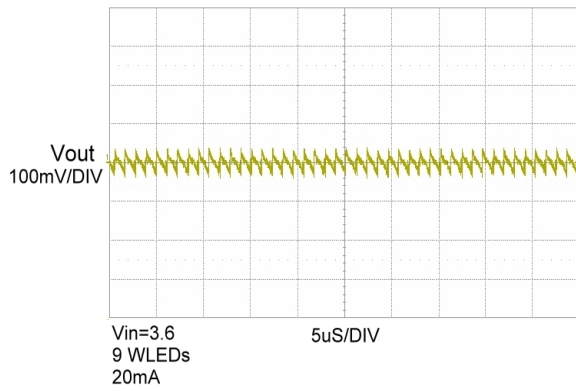
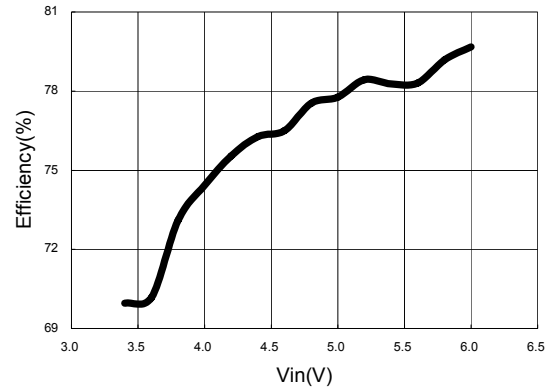

Supply Current (Vctrl = 0V)

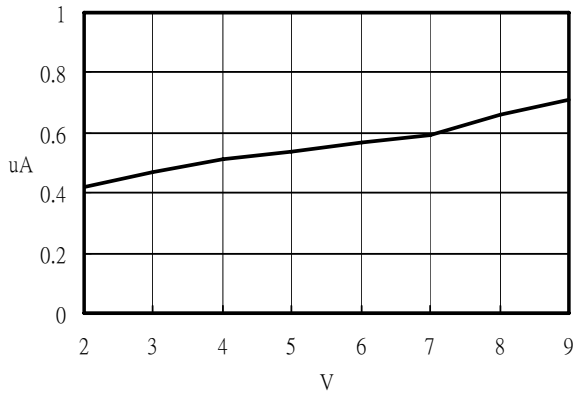

Switching Frequency

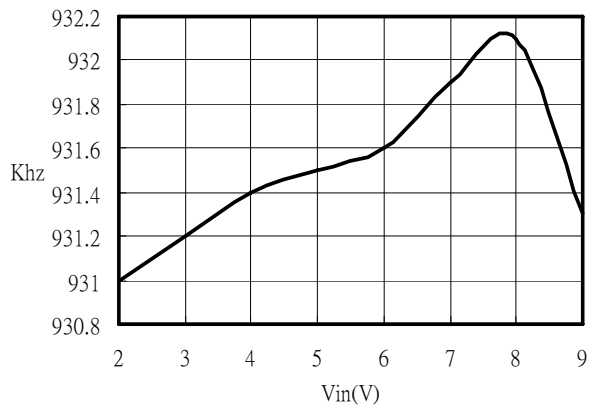

Switch Leakage Current

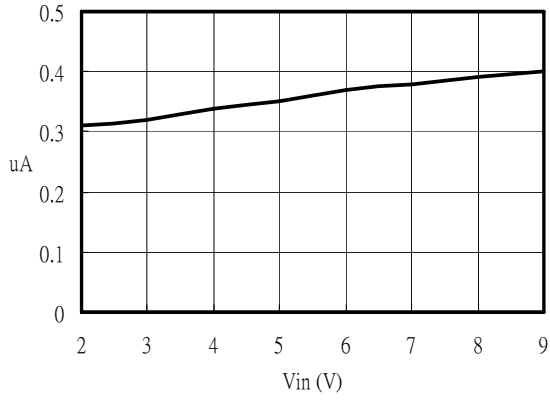

CTRL Pin Bias Current

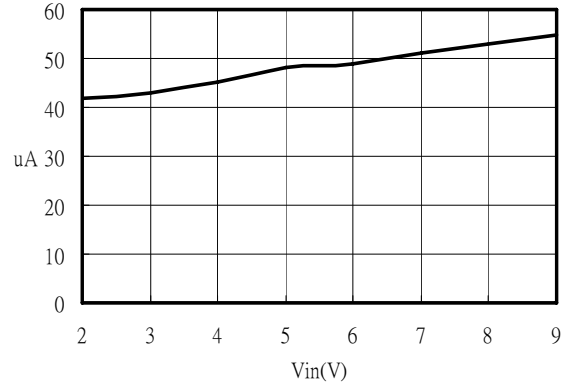

Supply Current (Vctrl = Vin)

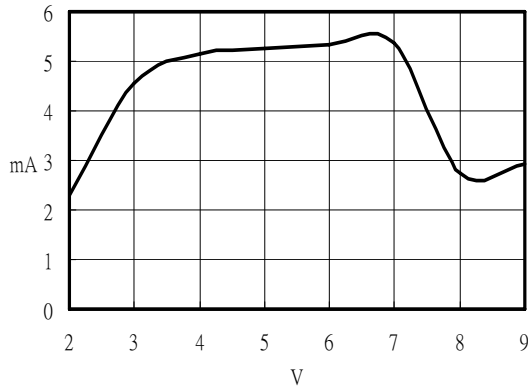

Vcesat

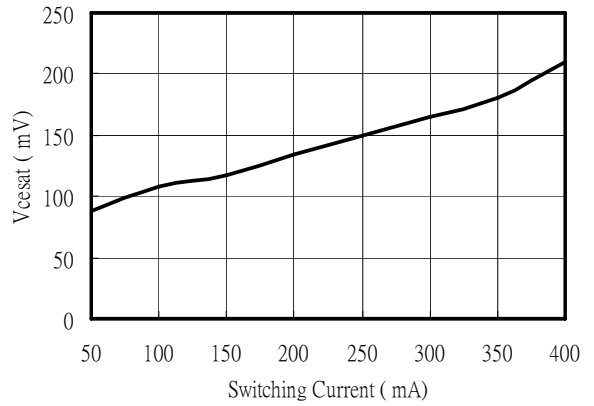



**Functional Block**

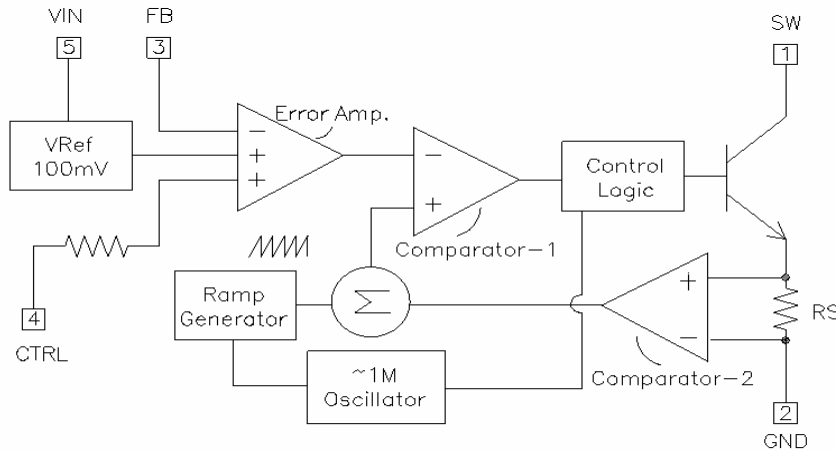

Figure 3: YB1518 Block Diagram

**Operation**

The YB1518 uses a constant frequency, current mode control scheme to regulate the output LED current. Its operation can be understood by referring to the block diagram in Figure 3. At the start of each oscillator cycle, a voltage proportional to the switch current is added to a ramp output and the resulting sum is fed into the positive terminal of the PWM comparator (comparator-1). When this voltage exceeds the level of the comparator negative input, the peak current has been reached, and the SR latch (in Control Logic) is reset and turns off the power switch. The voltage at the negative input of the comparator comes from the output of the error amplifier. The error amplifier sets the correct peak current level to keep the output in regulation. If the error amplifier's output increases, more current is delivered to the output; if it decreases, less current is delivered.

**Application Information**

**Soft Start and Current Limit**

The internal soft start circuit minimizes the inrush current during turning on YB1518. The maximum switch current is limited to about 230 mA by the chip.

**LED Current and Dimming Control**

The LED's current is set by a resistor connected at FB pin to GND using:

$$I_{LED} = \frac{100mV}{R_{LED}}$$

The maximum LED current set initially can be reduced by pulse width modulating the CTRL. A better approach is to adjust the feedback voltage for dimming control. Either a DC level signal or a filtered PWM signal can be used to control the LED current as illustrated in Figure 4 and Figure

5 respectively. Using the above different scheme, the LED current can be controlled from 0% to 100% to its maximum value.

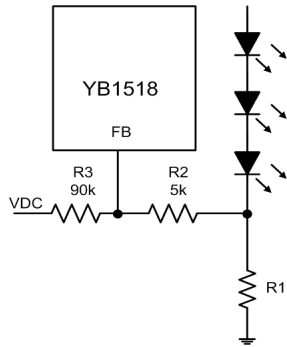

V <sub>DC</sub> (V)	V <sub>FB</sub>	I <sub>out</sub> (mA)
2	0	0
1.8	2.2	0.43
1.6	9.2	1.8
1.4	19.6	3.6
1.2	31.1	6
1	43.4	8.5
0.8	63	12.3
0.6	74	14.5
0.4	86.4	16.9
0.2	96.9	19
0	102	20

Figure 4. Dimming Control Using a DC Voltage

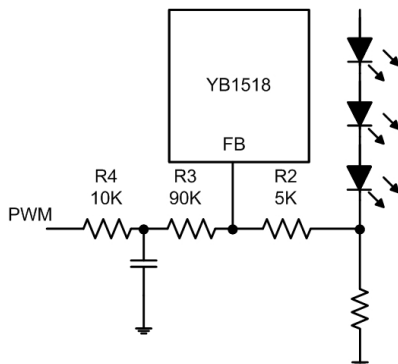

Duty	I <sub>out</sub> ( mA)
0%	20
20%	17.4
30%	15
40%	12.4
50%	10
60%	8
70%	6.4
80%	4.07
100%	0

PWM : 2V ; 1KHz ;  
V<sub>in</sub>=3.6V

Figure 5. Dimming Control Using a Filtered PWM Signal

### Over Voltage Protection

The YB1518 has an internal over voltage protection circuit which also acts as an open-circuit protection. In the cases of open circuit or the LEDs failure, the LEDs are disconnected from the circuit, and the feedback voltage will be zero. The YB1518 will then switch to a high duty cycle resulting in a high output voltage, which may cause SW pin voltage to exceed its maximum 34V rating. The YB1518 will shutdown automatically until input condition changes to bring it out of the shutdown mode.

### Inductor Selection

A 22uH inductor is recommended for most applications to drive more than 5 LEDs.

Although small size and high efficiency are major concerns, the inductor should have low core losses at 1MHz and low DCR (copper wire resistance).

### Diode Selection

To maintain high efficiency, the average current rating of the Schottky diode should be large than the peak inductor current,  $IPK$ . Schottky diode with a low forward drop and fast switching speeds are ideal for increase efficiency in portable application. Choose a reverse breakdown of the Schottky diode large than the output voltage.

### Capacitor Selection

Choose low ESR capacitors for the output to minimize output voltage ripple. Multilayer capacitors are a good choice for this as well. A 1 $\mu$ F capacitor is sufficient for 2~6 LEDs, 2.2 $\mu$ F is for 7~8 LEDs and 4.7 $\mu$ F is for 9 LEDs applications. For additional bypassing, a 100nF ceramic capacitor can be used to shunt high frequency ripple on the input.

The input bypass capacitor  $C_{in}$ , as shown in Figure 1, must be placed close to the IC. This will reduce copper trace resistance which affects input voltage ripple of the IC. For additional input voltage filtering, a 100nF bypass capacitor can be placed in parallel with  $C_{in}$  to shunt any high frequency noise to ground. The output capacitor,  $C_{out}$ , should also be placed close to the IC. Any copper trace

connections for the  $C_{out}$  capacitor can increase the series resistance, which directly effect output voltage ripple.

The feedback network, resistor  $R2$  should be kept close to the FB pin to minimize copper trace connections that can inject noise into the system. The ground connection for the feedback resistor network should connect directly to an analog ground plane. The analog ground plane should tie directly to the GND pin. If no analog ground plane is available, the ground connection for the feedback network should tie directly to the GND pin. Trace connections made to the inductor and Schottky diode should be minimized to reduce power dissipation and increase overall efficiency.

Package Description

