

### Description

The YB1520 is a step-up DC-DC converter; operates as current source to drive up to 18 white LEDs in parallel/series configuration. Series connecting of the LEDs provides identical LED currents resulting in uniform brightness and eliminating the need for ballast resistors. The light intensity of these LEDs is proportional to the current passing through them. The YB1520 switches at a fixed frequency of 700KHz, allowing the use of tiny, low profile inductors and capacitors to minimize footprint and cost in space consideration applications for cellular phone backlighting or other hand held equipment.

The YB1520 can drive up to 18 white LEDs from a 4.5V supply. The wide input voltage range from 2.7V to 7V is ideal for portable (5V) applications with higher conversion efficiency. To control LED brightness, the LED current can be pulsed by applying a PWM (pulse width modulated) signal with a frequency range of 100Hz to 50KHz to the CTRL pin.

YB1520 has integrated Over Voltage Protection that prevents damage to the device in case of a high impedance output due to faulty LED or open circuit caused by abnormal conditions.

### Features

- Built-in Internal Switch
- 2.7V to 7V Input Range
- <1uA Shutdown Current
- High Efficiency
- Drives up to 3S2P to 3S6P White LEDs ( $V_{IN}$  at 3.5V to 5V)
- Over Voltage Protection 30V
- Small 5-Lead SOT-23 Package

### Applications

- LCD Display Module
- White LED Backlighting
- PDAs, GPS terminals
- Digital Cameras
- Cellular Phone
- Electronic Books
- Portable Applications

### Typical Application Circuit

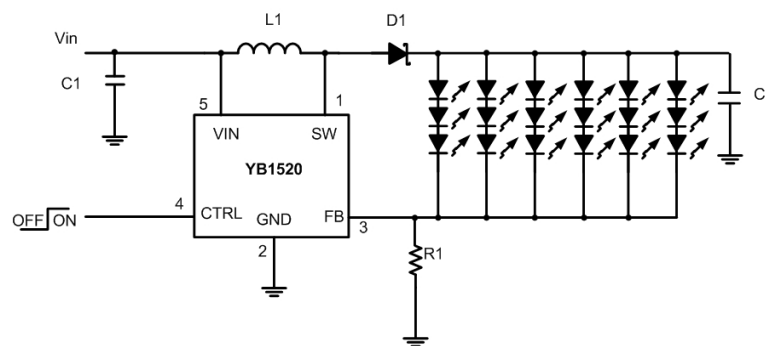

Figure 1: Typical Application Circuit

### Pin Configuration

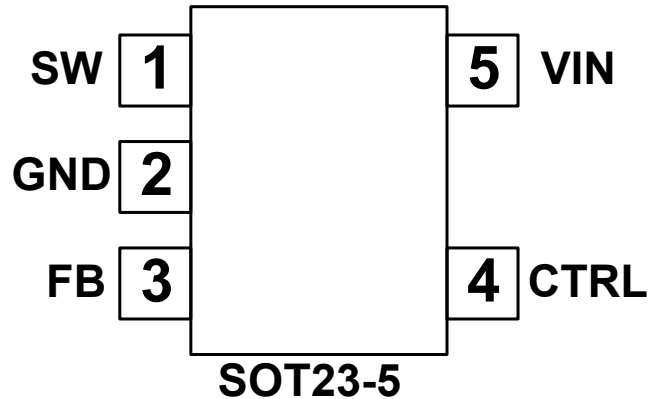

Figure 2: Pin Configuration

### Pin Description

Table 1

Pin	NAME	Description
1	SW	Switching Pin. This is the collector of the internal NPN power switch. Connect to inductor and diode. Minimize the metal trace area connected to this pin to reduce EMI.
2	GND	Ground Pin. Connect directly to local ground plane.
3	FB	Feedback Pin. Reference voltage is 200mV. Connect LEDs and a resistor at this pin. LED current is determined by the resistance and CTRL voltage.
4	CTRL	Shutdown Pin and Dimming Control Pin. VCTRL > 1.8V generates full-scale LED current. VCTRL < 0.4V chip is off. Switching from 0.4V to 2.0V, PWM duty cycle controls the LED current.
5	VIN	Input Supply Pin. Bypass this pin with a capacitor as close to the device as possible.

### Ordering Information

Order Number	Package Type	Supplied As	Package Marking
YB1520ST25	SOT23-5	3000 units Tape & Reel	Please contact sales representative

### Absolute Maximum Ratings

V <sub>IN</sub> .....	10V
SW Voltage .....	32V
FB Voltage .....	5V
CTRL Voltage.....	5V
Maximum Junction Temp, T <sub>J</sub> .....	150°C
Lead Temperature (Soldering 10 sec).....	300°C

### Recommended Operating Conditions

Operating Temperature.....	-40°C to 85°C
Supply Voltage.....	2.7V to 7V
SW Voltage.....	20V

### Electrical Characteristics

**Table 2** (V<sub>IN</sub> = 3.3V, C<sub>IN</sub> = 1uF, C<sub>OUT</sub> = 4.7uF, T<sub>A</sub>=25°C, unless otherwise noted.)

Description	Symbol	Test Conditions	MIN	TYP	MAX	Units
Input Voltage Range	V <sub>IN</sub>		2.7		7	V
Not Switching	I <sub>Q</sub>	V <sub>FB</sub> = 0.3V	1.2	1.5	1.7	mA
Shutdown	I <sub>SD</sub>	CTRL = 0V		0.3	1	uA
Feedback Voltage	V <sub>FB</sub>	I <sub>OUT</sub> = 20mA, V <sub>OUT</sub> = 12.5V Circuit of Figure 1	180	200	220	mV
Switch Current Limit	I <sub>CL</sub>	100% duty cycle	420	450		mA
	I <sub>LIM</sub>	40% duty cycle		250		mA
FB Pin Bias Current	I <sub>B</sub>	V <sub>FB</sub> = 200mV	2	10	20	uA
Switching Frequency	F <sub>SW</sub>		680	700	720	KHz
Maximum Duty Cycle	D <sub>MAX</sub>				85	%
Minimum Duty Cycle	D <sub>MIN</sub>		20		25	%
Switch V <sub>cesat</sub>	V <sub>SAT</sub>	At I <sub>SW</sub> = 200mA		120		mV
Switch Leakage Current	I <sub>LKG</sub>	CTRL = 0.3V		1		uA
V <sub>CTRL</sub> for Full LED Current	V <sub>CTL</sub>	Full On		1.7	1.8	V
		Full Off		0.2	0.3	V
CTRL Pin Bias Current	I <sub>CTL</sub>	CTRL = 2V		20		uA
Over Voltage Protection	OVP			30		V
Over Thermal Protection	OTP			160		°C
Thermal Resistance	θ <sub>JA</sub>			220		°C/W

**Note :**

Absolute maximum ratings are limits beyond which damage to the device may occur. The maximum allowable power dissipation is a function of maximum junction temperature, T<sub>J(MAX)</sub>, the junction to ambient thermal resistance, θ<sub>JA</sub>, and the ambient temperature. The maximum allowable power dissipation at any ambient temperature is calculated using: P<sub>D(MAX)</sub> = [T<sub>J(MAX)</sub> - T<sub>A</sub>] / θ<sub>JA</sub>. Exceeding the maximum allowable power dissipation will cause excessive die temperature. All limits at temperature extremes are guaranteed via correlation using standard statistical methods.

**Typical Performance Characteristics**

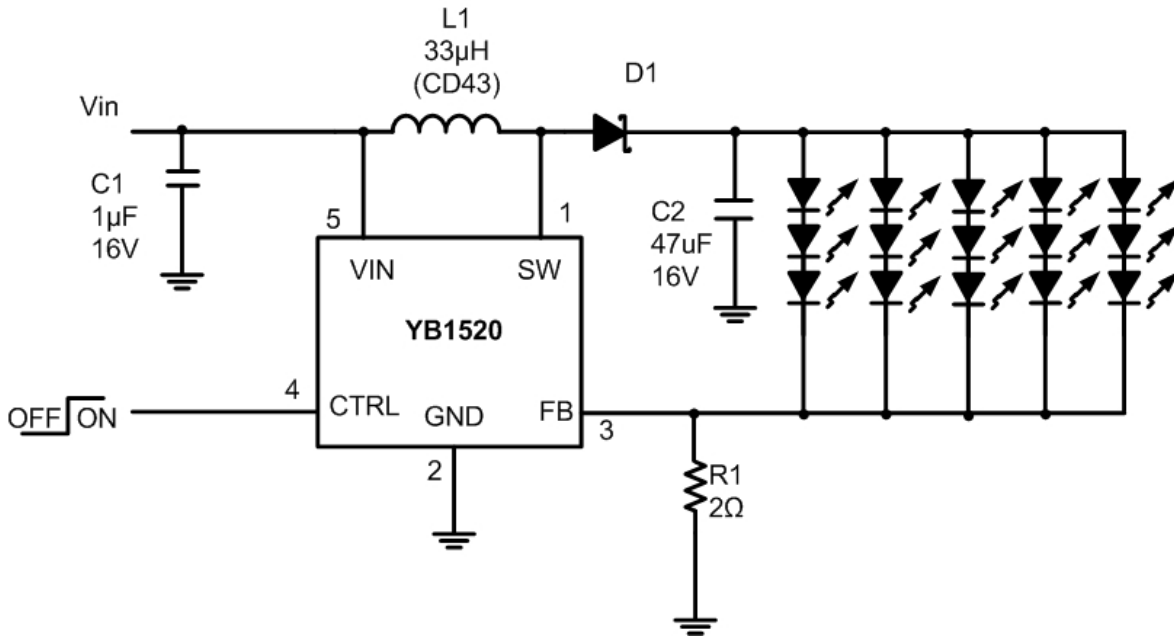

**Vout Ripple**

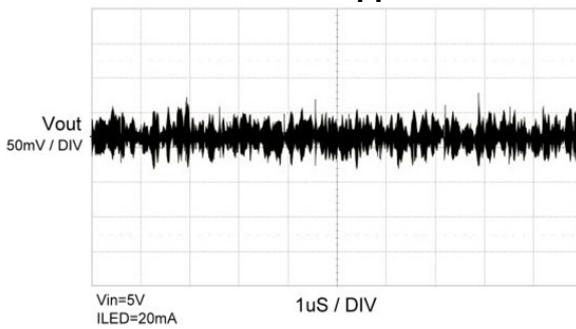

**SW Waveform**

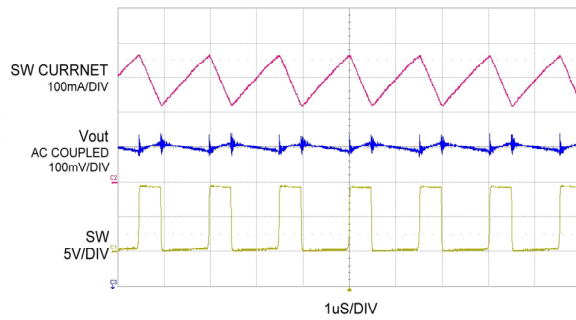

**Vin & Efficiency**

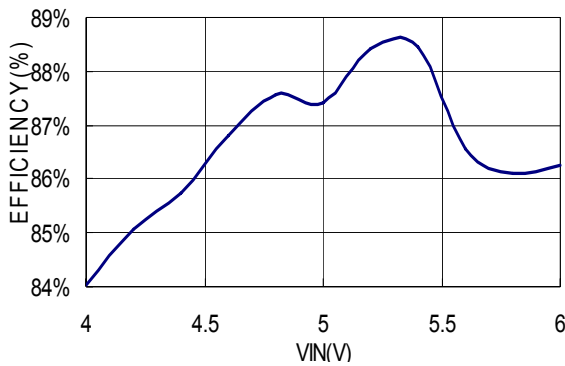

**Vin & Iout**

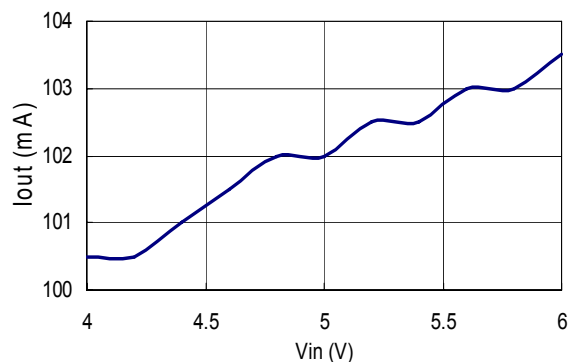

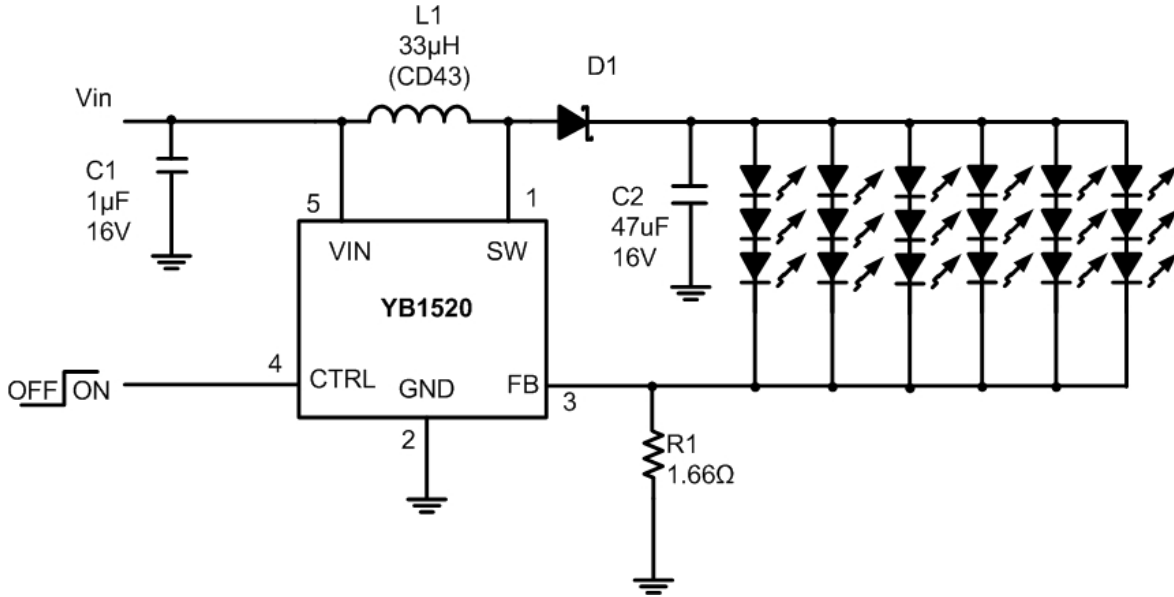

**Vout Ripple**

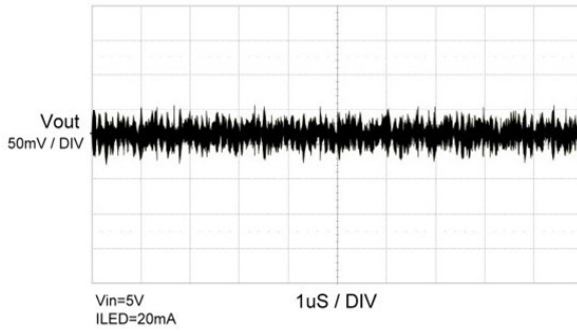

**SW Waveform**

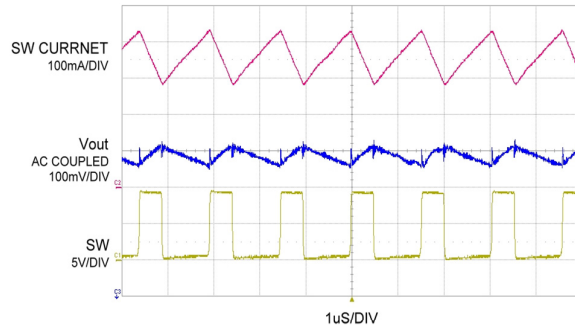

**Vin & Efficiency**

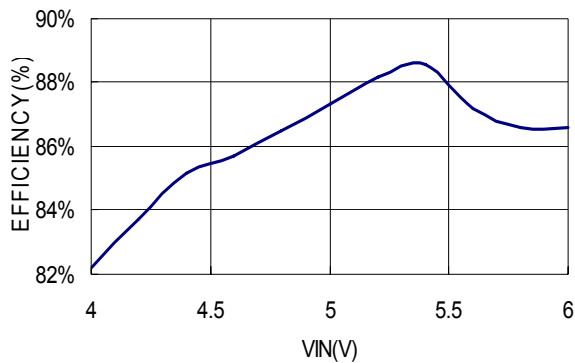

**Vin & Iout**

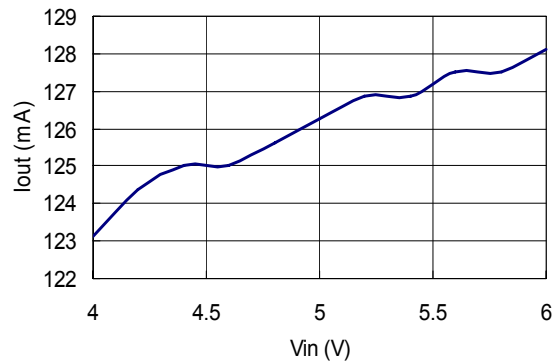

**Typical Performance Characteristics**

**Drive Switch Saturation Voltage(Vcesat)**

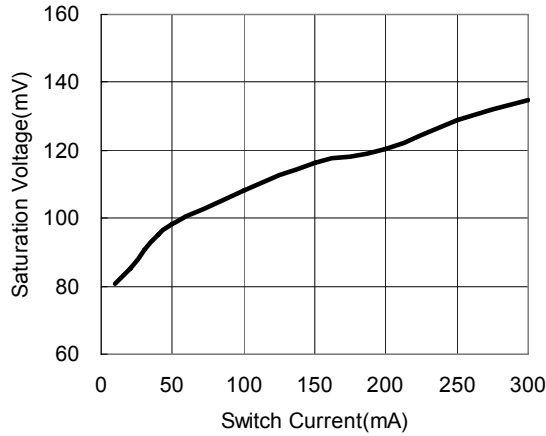

**Switching Frequency**

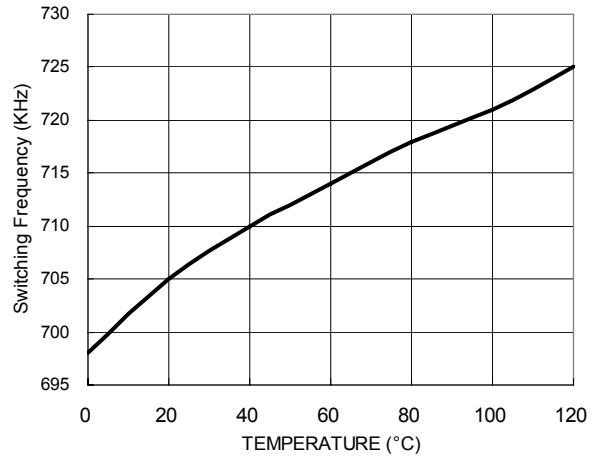

**Switch Leakage Current**

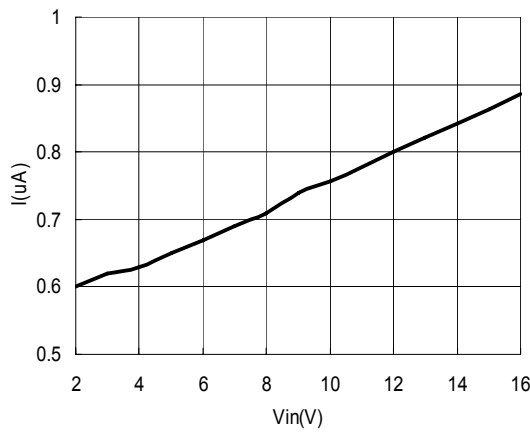

**Supply current test**

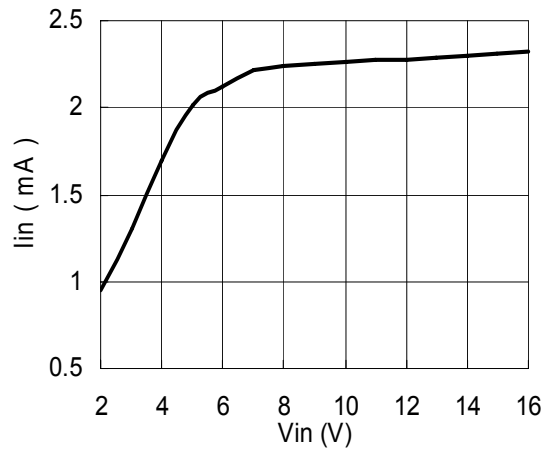

### Function Block

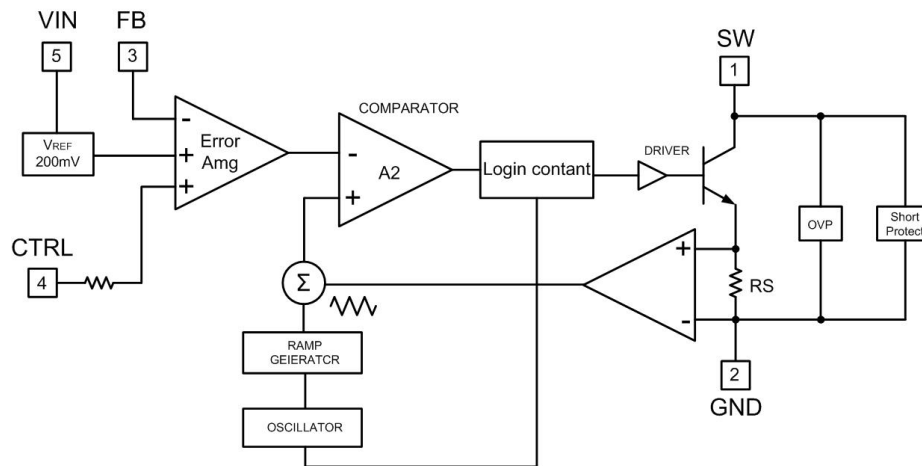

Figure 3: YB1520 Block Diagram

### Operation

The YB1520 uses a constant frequency, current mode control scheme to regulate the output LED current. Its operation can be understood by referring to the block diagram in Figure 3. At the start of each oscillator cycle, a voltage proportional to the switch current is added to a ramp output and the resulting sum is fed into the positive terminal of the PWM comparator. When this voltage exceeds the level of the comparator negative input, the peak current has been reached, and the SR latch is reset and turns off the power switch. The voltage at the negative input of the comparator comes from the output of the error amplifier. The error amplifier sets the correct peak current level to keep the output in regulation. If the error amplifier's output increases, more current is delivered to the output; if it decreases, less current is delivered.

### Application Information

#### Inrush Current

The maximum switch current is limited to about 450mA by the chip. Typically, a larger  $C_{OUT}$  will increase the duration of high current. However, when  $V_{IN}$  is first connected, an even larger current can flow into  $C_{OUT}$ . This occurs when the SW pin is open circuit and the  $C_{OUT}$  voltage changes from 0V to  $V_{IN}$  in a few microseconds. Because the duration of this large current is short, it will usually not cause problems. If this current is not desirable, an external soft-start circuit can be added to significantly reduce this inrush current.

#### LED Current and Dimming Control

The LED's current is set by a resistor connected at FB pin to GND using:

$$I_{LED} = \frac{200mV}{R_{LED}}$$

The maximum LED current set initially can

be reduced by pulse width modulating the CTRL. A better approach is to adjust the feedback voltage for dimming control. Either a DC level signal or a filtered PWM signal can be used to control the LED current as illustrated in Figure 4 and Figure 5 respectively. Using the above different scheme, the LED current can be controlled from 20% to 80% to its maximum value.

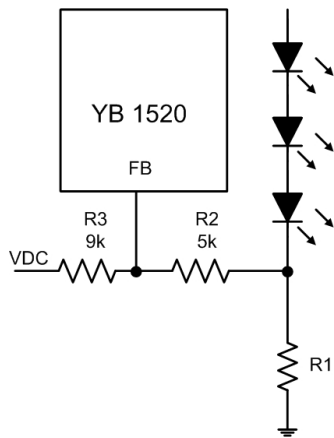

**Figure 4: Dimming Control Using a DC Voltage**

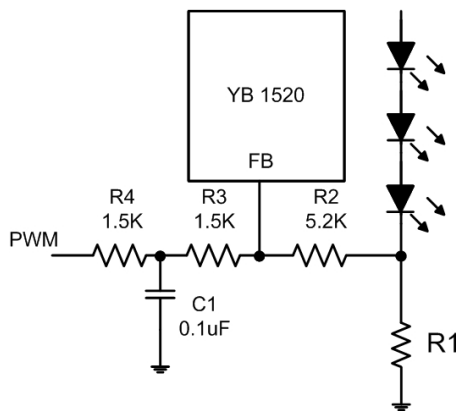

**Figure 5: Dimming Control Using a Filtered PWM Signal (1KHz, 2Vp-p, duty 20%~80%)**

**Over Voltage Protection**

The YB1520 has an internal over voltage protection circuit which also acts as an open-circuit protection. In the cases of open circuit or the LEDs failure, the LEDs are disconnected from the circuit, and the feedback voltage will be zero. The YB1520 will then switch to a high duty cycle resulting in a high output voltage, which may cause SW pin voltage to exceed its maximum 32V rating. The YB1520 will shutdown automatically until input condition changes to bring it out of the shutdown mode.

**Inductor Selection**

A 33uH inductor is recommended for most applications to drive 3X6 WLEDs in serials/parallel. Although small size and high efficiency are major concerns, the inductor should have low core losses at 1MHz and low DCR (copper wire resistance).

**Diode Selection**

To maintain high efficiency, the average current rating of the Schottky diode should be large than the peak inductor current,  $I_{PK}$ . Schottky diode with a low forward drop and fast switching speeds are ideal for increase efficiency in portable application. Choose a reverse breakdown of the Schottky diode large than the output voltage.

**Capacitor Selection**

Choose low ESR capacitors for the output to minimize output voltage ripple. Multilayer capacitors are a good choice for this as well. A 47uF capacitor is sufficient for most applications.



The input bypass capacitor  $C_{IN}$ , as shown in Figure 1, must be placed close to the IC. This will reduce copper trace resistance which affects input voltage ripple of the IC. For additional input voltage filtering, a 100nF bypass capacitor can be placed in parallel with  $C_{IN}$  to shunt any high frequency noise to ground. The output capacitor,  $C_{OUT}$ , should also be placed close to the IC. Any copper trace connections for the  $C_{OUT}$  capacitor can increase the series resistance, which directly effect output voltage ripple.

The feedback network, resistor R2 should be kept close to the FB pin to minimize copper trace connections that can inject noise into the system. The ground connection for the feedback resistor network should connect directly to an analog ground plane. The analog ground plane should tie directly to the GND pin. If no analog ground plane is available, the ground connection for the feedback network should tie directly to the GND pin. Trace connections made to the inductor and Schottky diode should be minimized to reduce power dissipation and increase overall efficiency.

### Package Information (SOT23-5)

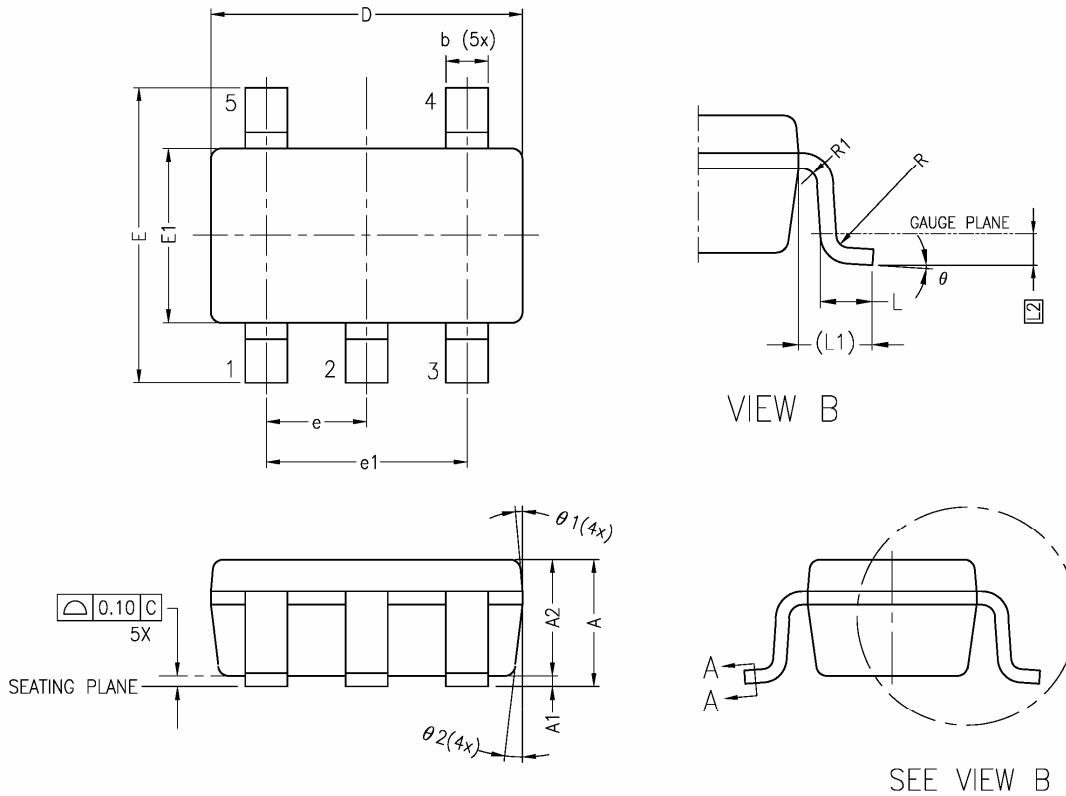

SYMBOLS	DIMENSIONS IN MILLIMETERS		
	MIN	NOM	MAX
A	1.05	1.20	1.35
A1	0.05	0.10	0.15
A2	1.00	1.10	1.20
b	0.35	—	0.50
b1	0.35	0.40	0.45
c	0.08	—	0.22
c1	0.08	0.13	0.20
D	2.80	2.90	3.00
E	2.60	2.80	3.00
E1	1.50	1.60	1.70
e	0.95 BSC		
e1	1.90 BSC		
L	0.35	0.43	0.60
L1	0.60 REF		
L2	0.25 BSC.		
R	0.10	—	—
R1	0.10	—	0.25
θ	0°	4°	8°
θ1	5°	6°	15°
θ2	5°	8°	15°

**NOTICE:**

- The information described herein is subject to change without notice.
- Yobon does not assume any responsibility for use of any circuitry or applications described herein, nor does it convey any patent license.